

REVISION C

DO NOT SCALE FROM THIS PRINT

- NOTES:
 1. CONTACT CONFIGURATION NOT AVAILABLE AS STANDARD.
 2. Ⓢ REPRESENTS A CRITICAL DIMENSION.
 3. MAXIMUM BURR ALLOWANCE: .038 [.0015].
 4. MINIMUM PUSHOUT FORCE: 2.22N [.5 LB].
 5. PARTS TO BE PACKAGED IN TRAYS.

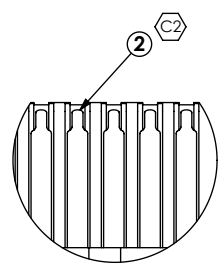
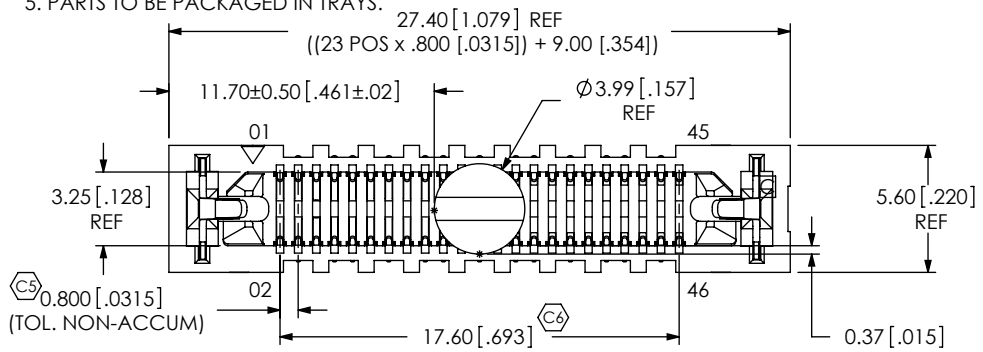

DETAIL 'B'
SCALE 6 : 1
SE SIDE

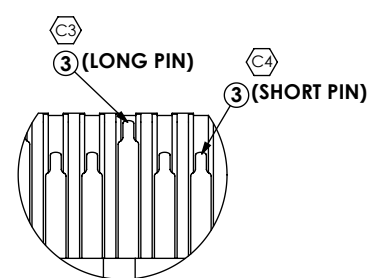

DETAIL 'D'
SCALE 6 : 1
DP SIDE

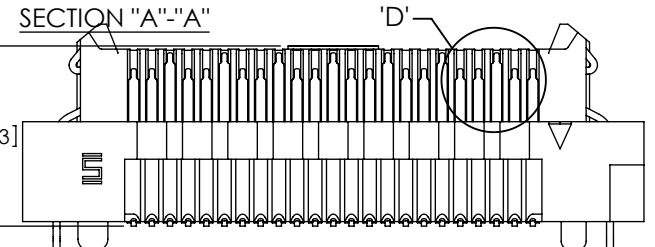
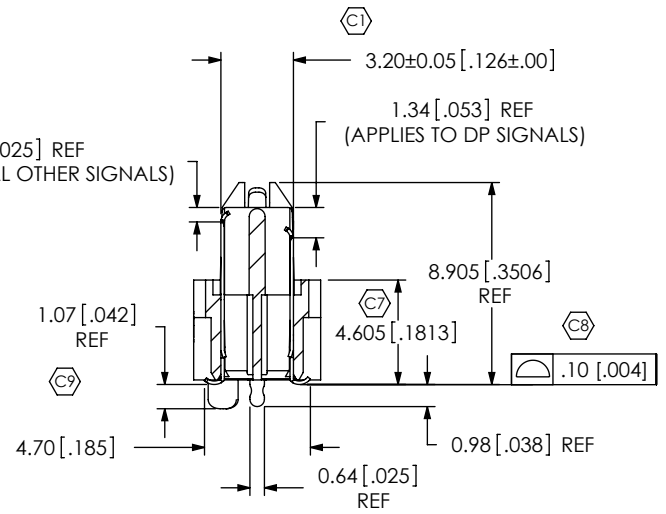
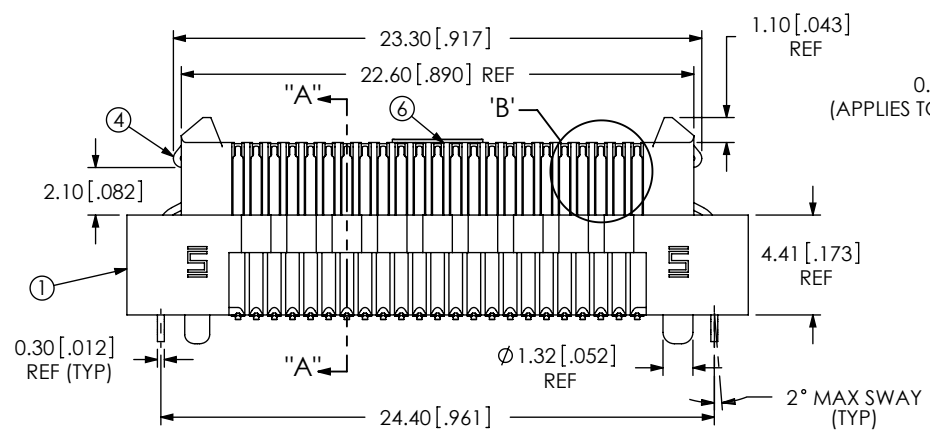

ODD ROW (DP SIDE, HOT PLUG SIDE)
(PIN ORIENTATION TO BE EXACTLY AS SHOWN)

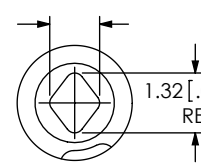
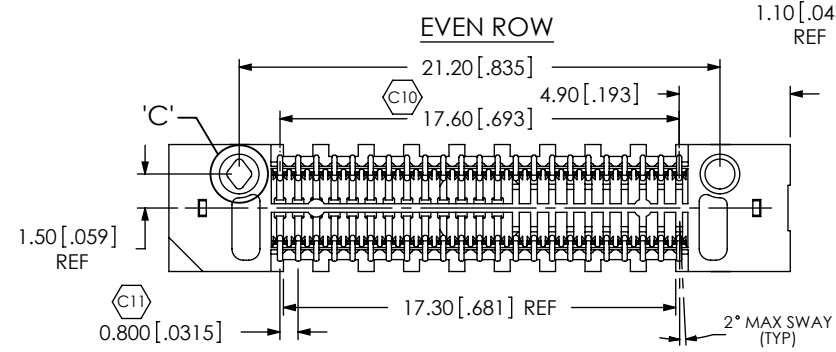

DETAIL 'C'
SCALE 6 : 1

ITEM NO.	PART NUMBER	QUANTITY	MATERIAL
1	ERM8-023-05.0-DV-L	1.0000	VECTRA E130i, COLOR: BLACK
2	T-1M37-05.0-S	23.0000	PHOS BRONZE, 521 HARD TEMPER
3	T-1M48-05.0-S	23.0000	PHOS BRONZE, 521 HARD TEMPER
4	WT-29-03-F	2.0000	BeCu #25, 1/2 HT
5	TY-ERM8028-23-5-L	1.0000	BLACK HIPS
6	K-DOT-.157-.250-.005	1.0000	POLYIMIDE FILM

UNLESS OTHERWISE SPECIFIED, DIMENSIONS ARE IN INCHES. TOLERANCES ARE:
 DECIMALS ANGLES
 .X: ±.3[.01] 2°
 .XX: ±.13[.005]
 .XXX: ±.051[.0020]

PROPRIETARY NOTE
 THIS DOCUMENT CONTAINS INFORMATION CONFIDENTIAL AND PROPRIETARY TO SAMTEC, INC. AND SHALL NOT BE REPRODUCED OR TRANSFERRED TO OTHER DOCUMENTS OR DISCLOSED TO OTHERS OR USED FOR ANY PURPOSE OTHER THAN THAT WHICH IT WAS OBTAINED WITHOUT THE EXPRESSED WRITTEN CONSENT OF SAMTEC, INC.

samtec
 520 PARK EAST BLVD, NEW ALBANY, IN 47150
 PHONE: 812-944-6733 FAX: 812-948-5047
 e-Mail: info@SAMTEC.com code: 55322

DO NOT SCALE DRAWING SHEET SCALE: 1:0.3333
 PLATING:
 CONTACT AREA: .000030 GOLD OVER .000050 NICKEL
 REMAINDER: .000200 REF TIN OVER .000050 NICKEL
 LATCHES: .000003 GOLD OVER .000050 NICKEL

DESCRIPTION: MODIFIED ERM8 ASSEMBLY
 DWG. NO. ASP-130366-01

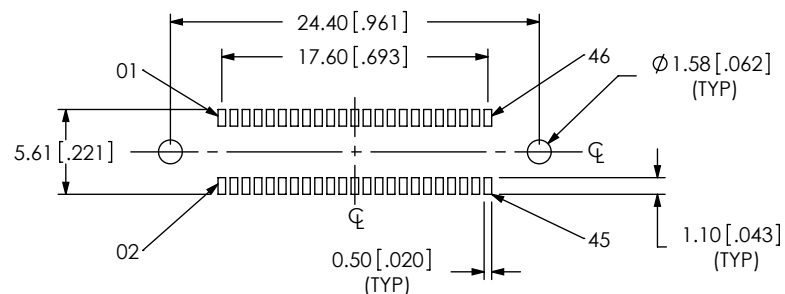
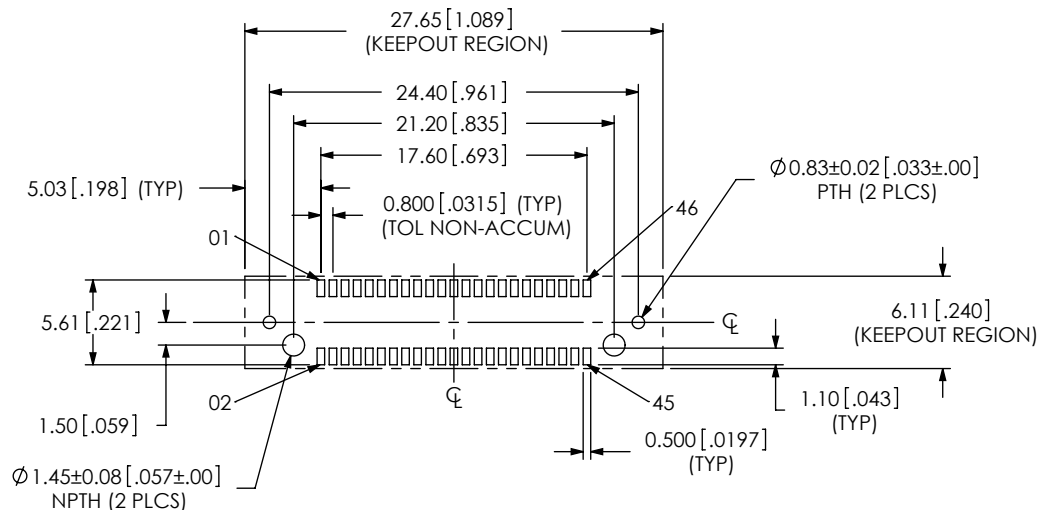
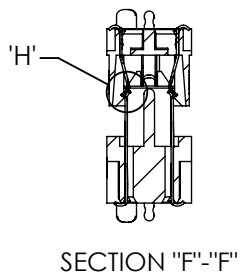
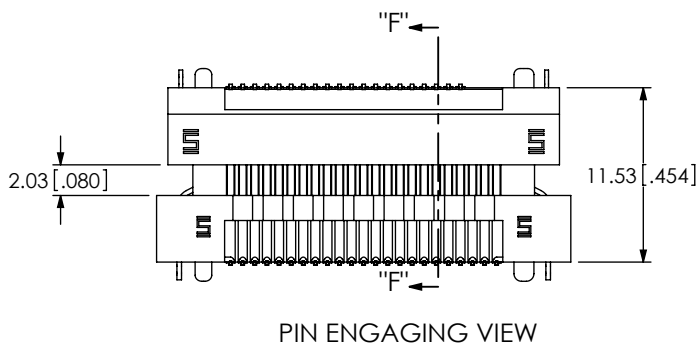
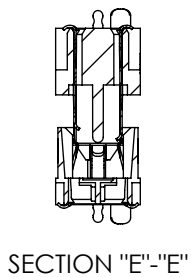
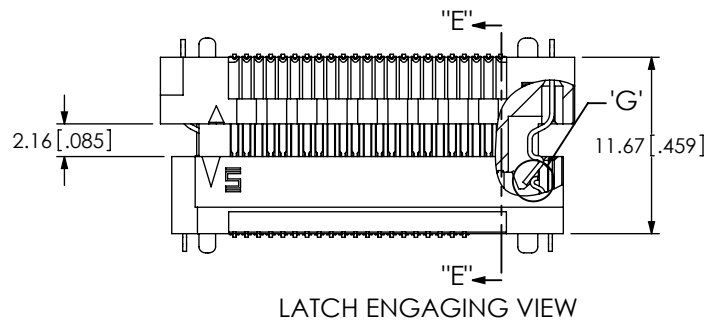

DETAIL 'G'
SCALE 4 : 1

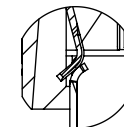

DETAIL 'H'
SCALE 6 : 1

PROPRIETARY NOTE

THIS DOCUMENT CONTAINS INFORMATION CONFIDENTIAL AND PROPRIETARY TO SAMTEC, INC. AND SHALL NOT BE REPRODUCED OR TRANSFERRED TO OTHER DOCUMENTS OR DISCLOSED TO OTHERS OR USED FOR ANY PURPOSE OTHER THAN THAT WHICH IT WAS OBTAINED WITHOUT THE EXPRESSED WRITTEN CONSENT OF SAMTEC, INC.



520 PARK EAST BLVD, NEW ALBANY, IN 47150
PHONE: 812-944-6733 FAX: 812-948-5047
e-Mail: info@SAMTEC.com code: 55322

SHEET SCALE: 2:1

DESCRIPTION: MODIFIED ERM8 ASSEMBLY

DWG. NO. ASP-130366-01

BY: D FRALEY 03/19/2007 SHEET 2 OF 2