

REVISION

A JB J HENRY
 9/10/2013 ECN-211253
 RELEASE FOR PRODUCTION

NOTES:

1. CONTACT CONFIGURATION NOT AVAILABLE AS STANDARD.
2. [Cx-x-xx] REPRESENTS A CRITICAL DIMENSION.
3. MAXIMUM BURR ALLOWANCE: 0.038[.0015]
4. MINIMUM PUSHOUT FORCE: 2.22N [.5 LB]
5. PARTS TO BE PACKAGED IN TRAYS.

DESIGNED & DIMENSIONED
 IN MILLIMETERS [INCHES]

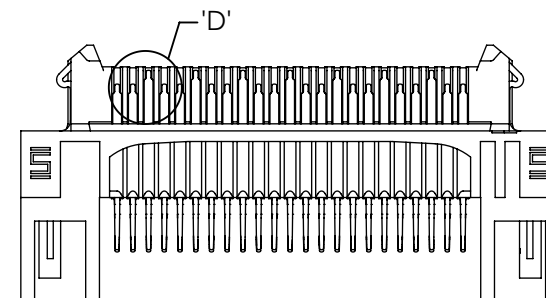
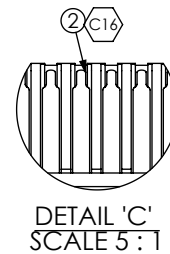
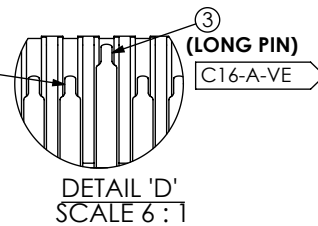
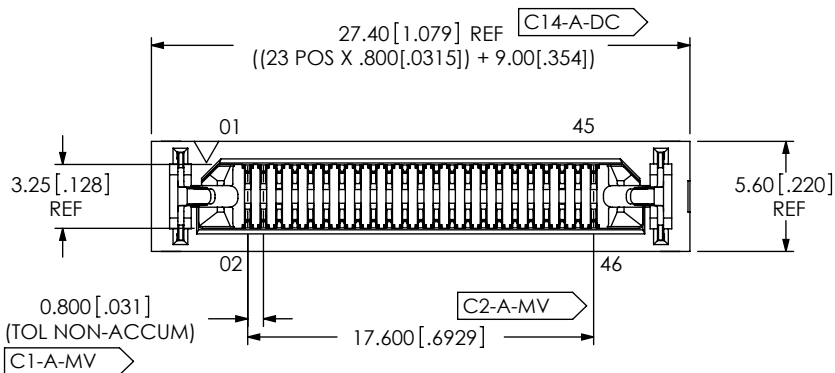

ODD ROW (DP SIDE, HOT PLUG SIDE)

BY SIGNING THIS DOCUMENT YOU ARE ACCEPTING THE CONDITIONS SET WITHIN. YOUR REQUIREMENTS MUST BE LISTED WITHIN THIS DRAWING. WHERE NO DIRECTION FROM THE CUSTOMER IS IDENTIFIED SAMTEC'S PROCESS REQUIREMENTS WILL BE USED.

DATE: _____
 COMPANY: _____
 CUSTOMER SIGNATURE: _____
 PRINTED NAME: _____
 PHONE NO.: _____
 EXCEPTIONS: _____

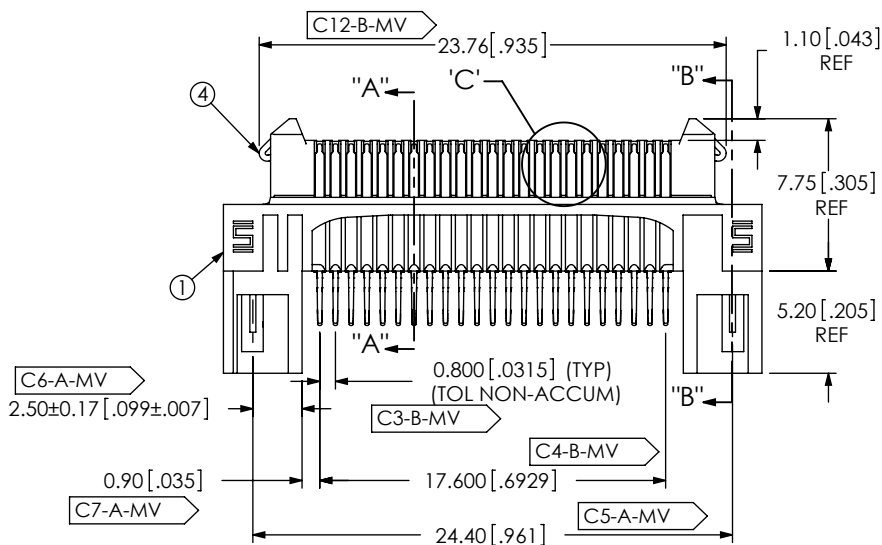

EVEN ROW

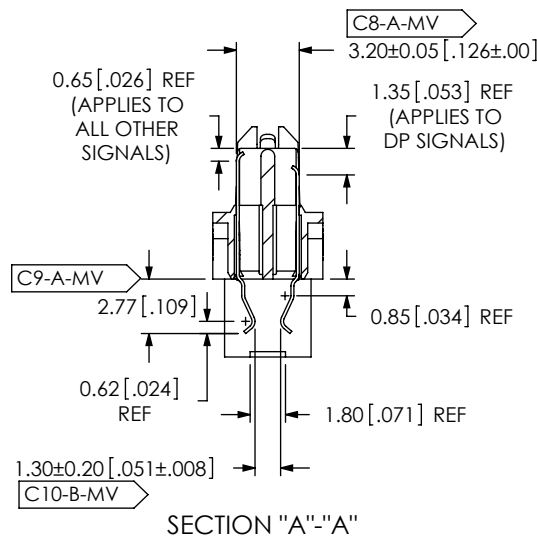

SECTION "A"-"A"

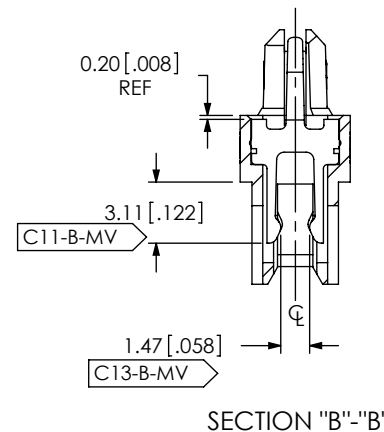

SECTION "B"-"B"

ITEM NO.	PART NUMBER	QUANTITY	MATERIAL
1	ERM8-023-D-EM2	1.0000	VECTRA E130i, COLOR: BLACK
2	T-1M47-01-S	23.000	PHOS BRONZE
3	T-1M47-03-S	23.000	PHOS BRONZE
4	WT-29-01-F	2.0000	BeCu
5	TY-ERM8030-23-EM2-L	1.0000	ANTI-STATIC BLACK HIPS

UNLESS OTHERWISE SPECIFIED, DIMENSIONS ARE IN INCHES. TOLERANCES ARE:
 DECIMALS ANGLES
 .X: ±.3[.01] 2°
 .XX: ±.13[.005]
 .XXX: ±.051[.0020]

PROPRIETARY NOTE
 THIS DOCUMENT CONTAINS INFORMATION CONFIDENTIAL AND PROPRIETARY TO SAMTEC, INC. AND SHALL NOT BE REPRODUCED OR TRANSFERRED TO OTHER DOCUMENTS OR DISCLOSED TO OTHERS OR USED FOR ANY PURPOSE OTHER THAN THAT WHICH IT WAS OBTAINED WITHOUT THE EXPRESSED WRITTEN CONSENT OF SAMTEC, INC.



520 PARK EAST BLVD, NEW ALBANY, IN 47150
 PHONE: 812-944-6733 FAX: 812-948-5047
 e-Mail: info@SAMTEC.com code 53322

DO NOT SCALE DRAWING SHEET SCALE: 2.6:1
 PLATING:
 CONTACTS:
 CONTACT AREA: .000030 GOLD OVER .000050 NICKEL
 REMAINDER: .000200 REF TIN OVER .000050 NICKEL
 LATCHES: .000003 GOLD OVER .000050 NICKEL

DESCRIPTION:
 MODIFIED 0.8mm EDGE RATE TERMINAL ASM
 DWG. NO.
ASP-133811-05
 BY: J. BROWNING 09/10/2013 SHEET 1 OF 2



DETAIL 'G'
SCALE 6:1



DETAIL 'H'
SCALE 6:1

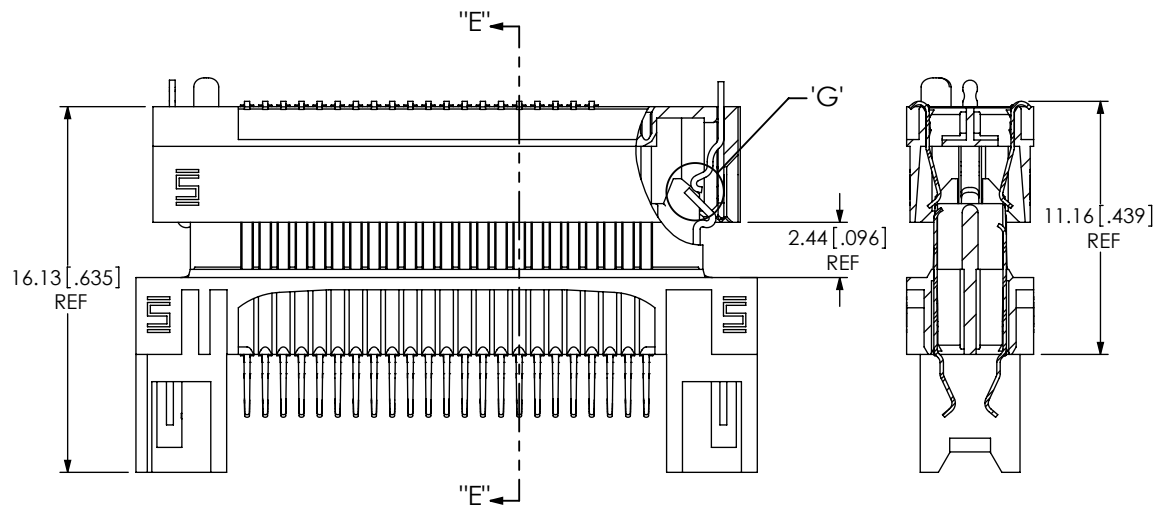
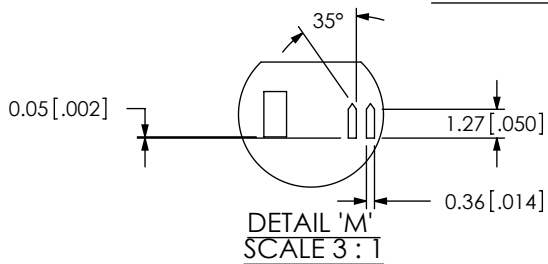

LATCH ENGAGING VIEW

SECTION "E"-"E"

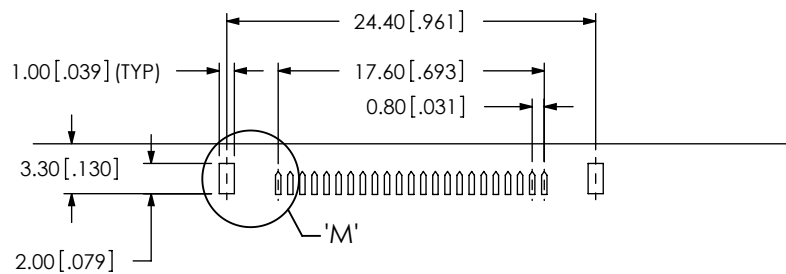

RECOMMENDED STENCIL LAYOUT

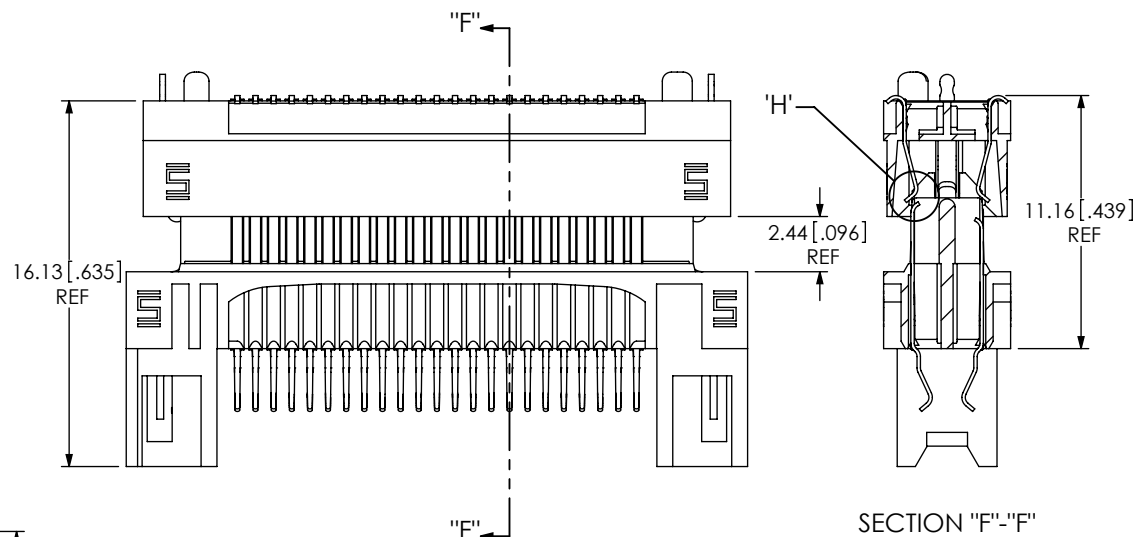

PIN ENGAGING VIEW

SECTION "F"-"F"

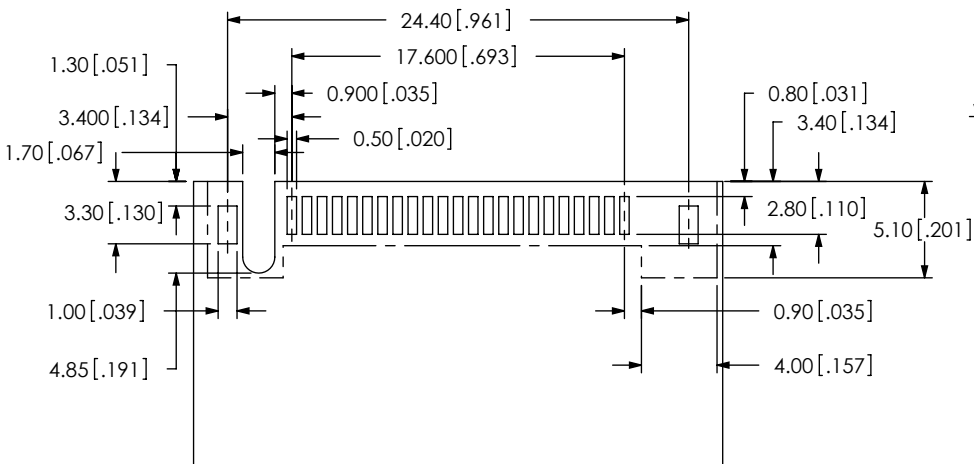

RECOMMENDED PCB LAYOUT

PROPRIETARY NOTE

THIS DOCUMENT CONTAINS INFORMATION CONFIDENTIAL AND PROPRIETARY TO SAMTEC, INC. AND SHALL NOT BE REPRODUCED OR TRANSFERRED TO OTHER DOCUMENTS OR DISCLOSED TO OTHERS OR USED FOR ANY PURPOSE OTHER THAN THAT WHICH IT WAS OBTAINED WITHOUT THE EXPRESSED WRITTEN CONSENT OF SAMTEC, INC.



520 PARK EAST BLVD, NEW ALBANY, IN 47150
PHONE: 812-944-6733 FAX: 812-948-5047
e-Mail info@SAMTEC.com code 53322

SHEET SCALE: 3:1

DESCRIPTION:
MODIFIED 0.8mm EDGE RATE TERMINAL ASM

DWG. NO.

ASP-133811-05

BY: J. BROWNING 09/10/2013 SHEET 2 OF 2