

DO NOT SCALE FROM THIS PRINT

NOTES:

1. VITA 57 CONNECTOR
2. FILL ROWS 3, 4, 7, 8 ONLY, NOT AVAILABLE AS STANDARD.
3. Ⓢ REPRESENTS A CRITICAL DIMENSION.
4. MINIMUM PUSHOUT FORCE: 0.50LBS.
5. PARTS TO BE PACKAGED IN TAPE & REEL.
6. DIMENSION C10 MUST BE MEASURED IN THE FOUR OUTSIDE CORNERS USING INSPECTION FIXTURE AT-1817-836-2. USE CO-AU-WI-2003-M FOR PROCESS
7. NOTE DELETED.
8. MAXIMUM ROW TO ROW VARIATION .003[0.08], MEASURED FIRST & LAST POSITIONS ONLY, ALL ROWS.
9. SOLDER CHARGE VOLUME IS .00000891 CUBIC INCHES (REF).

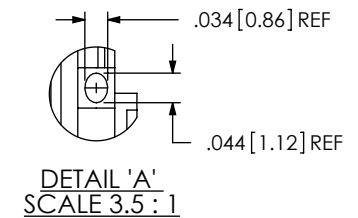
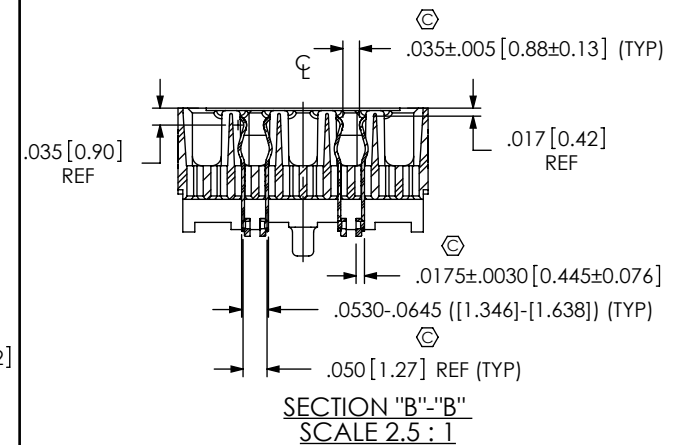
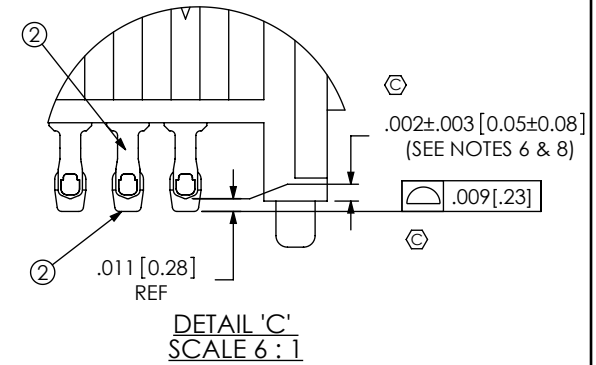
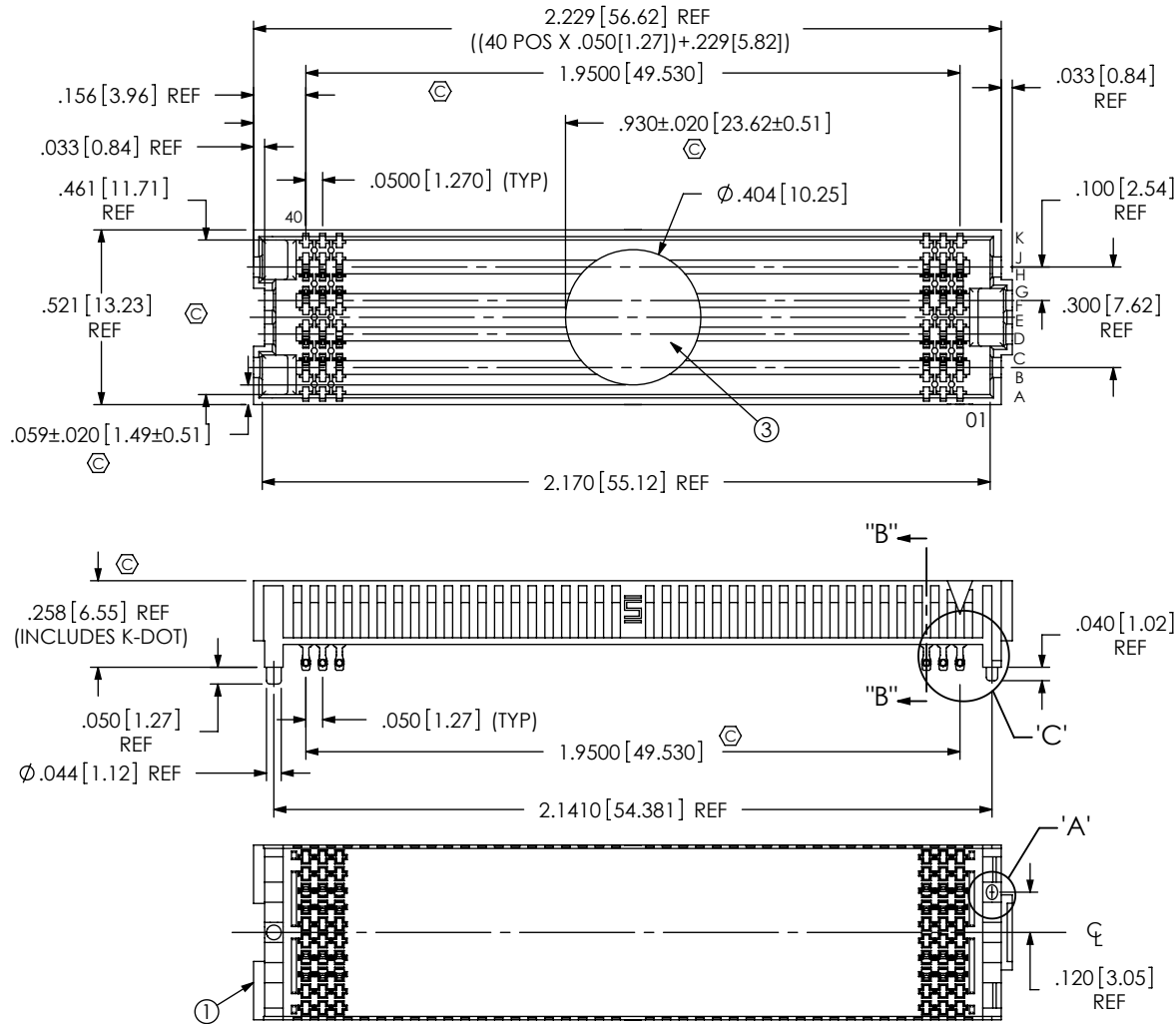

UNLESS OTHERWISE SPECIFIED, DIMENSIONS ARE IN INCHES.

TOLERANCES ARE:

DECIMALS ANGLES  
 .XX: ±.01[0.3] 2°  
 .XXX: ±.005[0.13]  
 .XXXX: ±.0020[0.051]

PROPRIETARY NOTE

THIS DOCUMENT CONTAINS CONFIDENTIAL AND PROPRIETARY INFORMATION AND ALL DESIGN, MANUFACTURING, REPRODUCTION, USE, PATENT RIGHTS AND SALES RIGHTS ARE EXPRESSLY RESERVED BY SAMTEC, INC. THIS DOCUMENT SHALL NOT BE DISCLOSED, IN WHOLE OR PART, TO ANY UNAUTHORIZED PERSON OR ENTITY NOR REPRODUCED, TRANSFERRED OR INCORPORATED IN ANY OTHER PROJECT IN ANY MANNER WITHOUT THE EXPRESS WRITTEN CONSENT OF SAMTEC, INC.

DO NOT SCALE DRAWING SHEET SCALE: 3:1

PLATING:  
 CONTACT AREA: .000030 GOLD OVER .000050 NICKEL  
 REMAINDER: .000200 REF TIN OVER .000050 NICKEL



520 PARK EAST BLVD, NEW ALBANY, IN 47150  
 PHONE: 812-944-6733 FAX: 812-948-5047  
 e-Mail: info@SAMTEC.com code: 55322

DESCRIPTION:  
 .050 PITCH SOCKET ARRAY ASSEMBLY

DWG. NO.  
**ASP-134603-01**

BY: S. SELLE 10/31/2007 SHEET 1 OF 4

ITEM NO.	PART NUMBER	QUANTITY	MATERIAL
1	SEAF-40-06.5-10-A	1.0000	LCP UL 94 V0, COLOR: BLACK
2	NEW-SUB-C-209-06.5-S-2	160.00	COPPER ALLOY/LEAD FREE SOLDER
3	K-DOT-.404-.500-.005	1.0000	POLYIMIDE FILM
4	CT-SEAF028MS	1.0000	CONDUCTIVE POLYMER

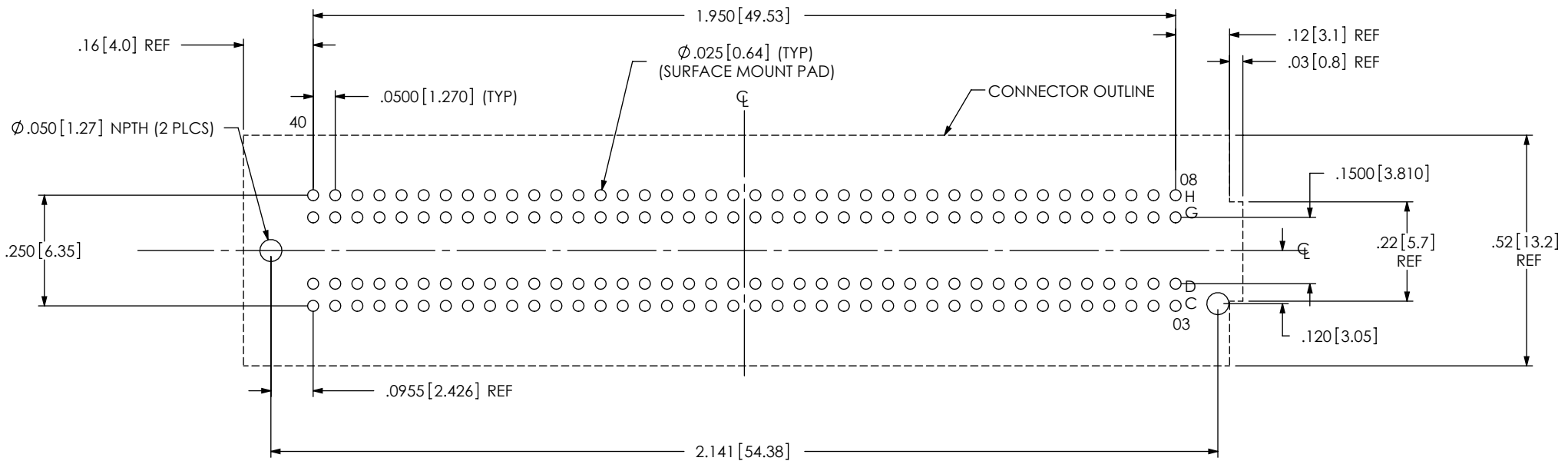

RECOMMENDED PCB LAYOUT FOR ASP-134603-01  
ALL DIMENSIONS SYMMETRIC ABOUT THE CENTERLINE

**PROPRIETARY NOTE**  
THIS DOCUMENT CONTAINS CONFIDENTIAL AND PROPRIETARY INFORMATION AND ALL DESIGN, MANUFACTURING, REPRODUCTION, USE, PATENT RIGHTS AND SALES RIGHTS ARE EXPRESSLY RESERVED BY SAMTEC, INC. THIS DOCUMENT SHALL NOT BE DISCLOSED, IN WHOLE OR PART, TO ANY UNAUTHORIZED PERSON OR ENTITY NOR REPRODUCED, TRANSFERRED OR INCORPORATED IN ANY OTHER PROJECT IN ANY MANNER WITHOUT THE EXPRESS WRITTEN CONSENT OF SAMTEC, INC.



520 PARK EAST BLVD, NEW ALBANY, IN 47150  
PHONE: 812-944-6733 FAX: 812-948-5047  
e-Mail: info@SAMTEC.com code: 55322

SHEET SCALE: 3:1

DESCRIPTION:  
.050 PITCH SOCKET ARRAY ASSEMBLY

DWG. NO.  
ASP-134603-01

BY: S SELLE 10/31/2007 SHEET 2 OF 4

NOTE:  
STENCIL TO BE .0060[0.152] THICK

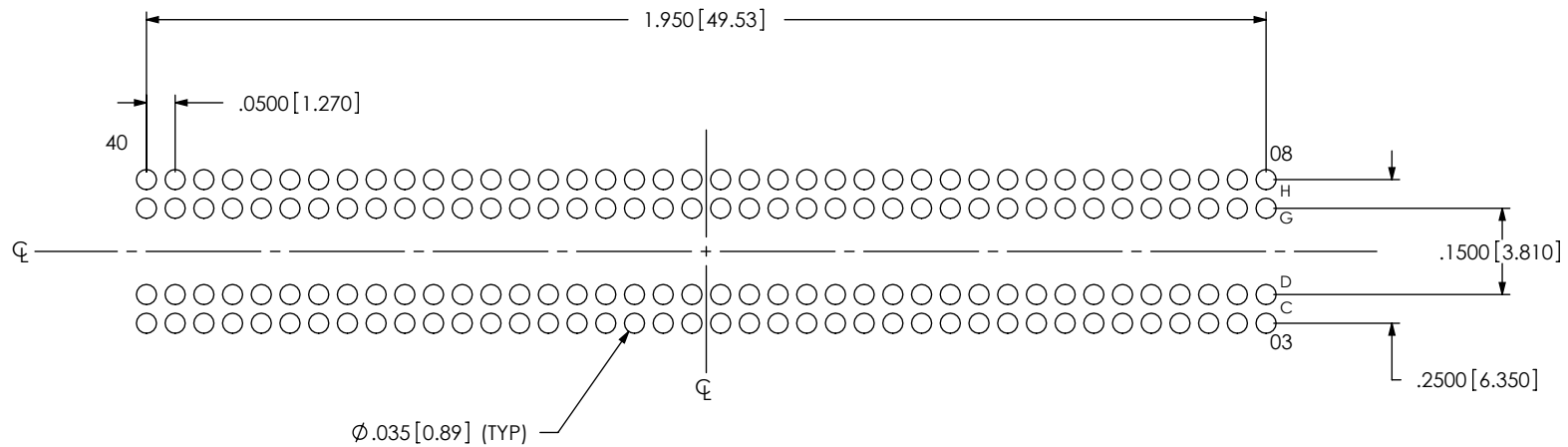

**RECOMMENDED STENCIL LAYOUT FOR ASP-134603-01**  
ALL DIMENSIONS SYMMETRIC ABOUT THE CENTERLINE

<p><b>PROPRIETARY NOTE</b></p> <p>THIS DOCUMENT CONTAINS CONFIDENTIAL AND PROPRIETARY INFORMATION AND ALL DESIGN, MANUFACTURING, REPRODUCTION, USE, PATENT RIGHTS AND SALES RIGHTS ARE EXPRESSLY RESERVED BY SAMTEC, INC. THIS DOCUMENT SHALL NOT BE DISCLOSED, IN WHOLE OR PART, TO ANY UNAUTHORIZED PERSON OR ENTITY NOR REPRODUCED, TRANSFERRED OR INCORPORATED IN ANY OTHER PROJECT IN ANY MANNER WITHOUT THE EXPRESS WRITTEN CONSENT OF SAMTEC, INC.</p>	 <p>520 PARK EAST BLVD, NEW ALBANY, IN 47150 PHONE: 812-944-6733 FAX: 812-948-5047 e-Mail: info@SAMTEC.com code: 55322</p>
<p>SHEET SCALE: 3:1</p>	<p>DESCRIPTION: .050 PITCH SOCKET ARRAY ASSEMBLY</p> <p>DWG. NO. <b>ASP-134603-01</b></p>
<p>c:\enterprise\aut\DWG\MISC\MKTG\ASP-134603-01.MKT5DDRW</p>	<p>BY: S SELLE 10/31/2007 SHEET 3 OF 4</p>

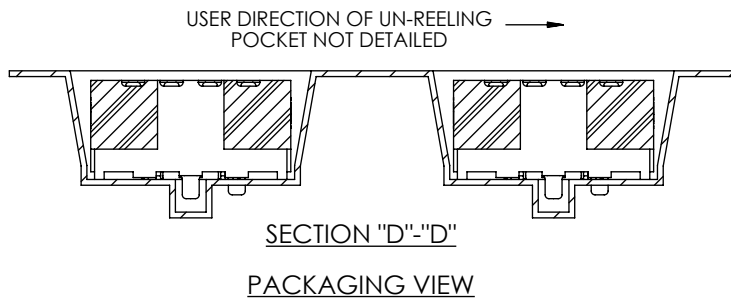
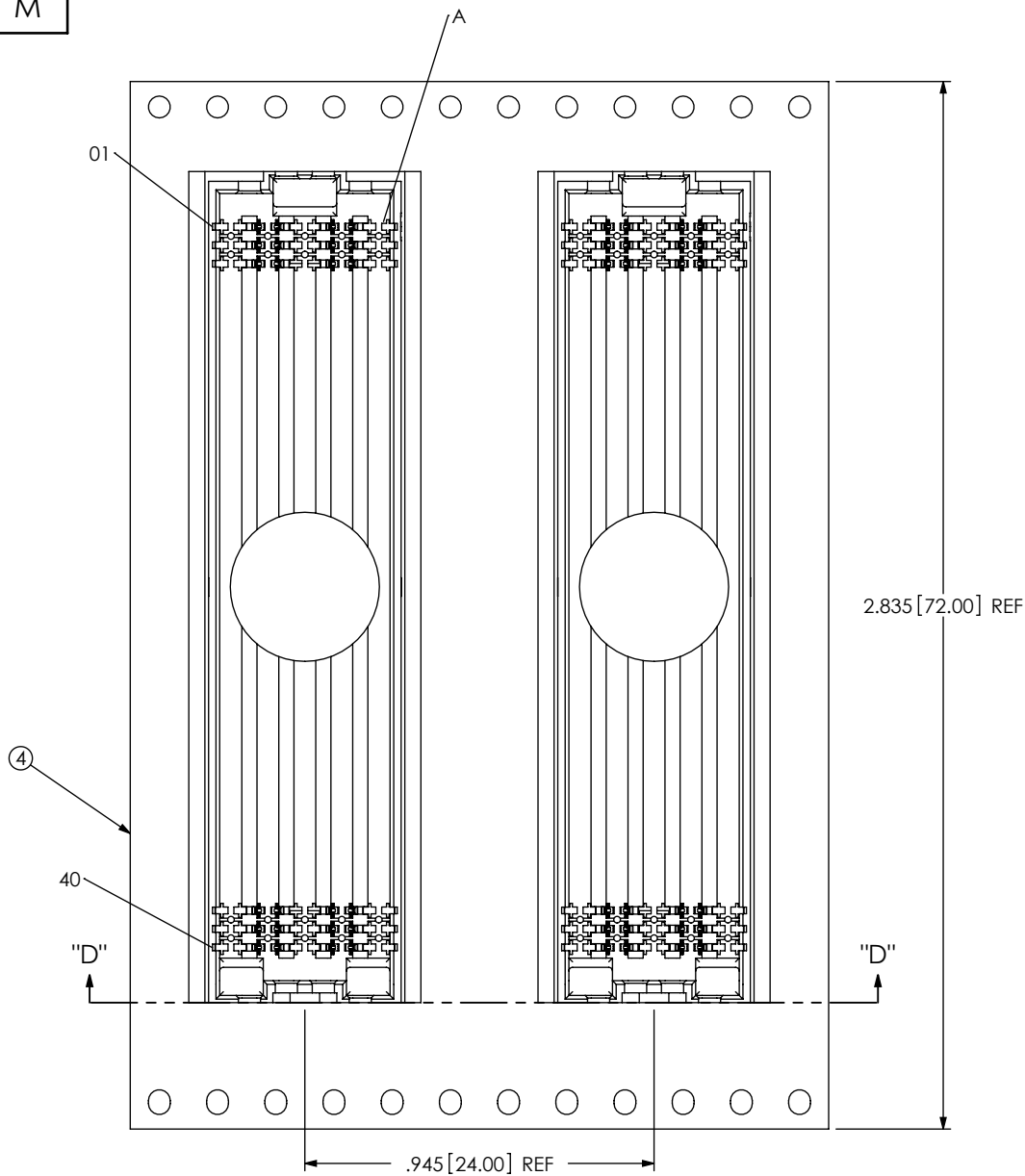

**PROPRIETARY NOTE**  
 \* THIS DOCUMENT CONTAINS CONFIDENTIAL AND PROPRIETARY INFORMATION AND ALL DESIGN, MANUFACTURING, REPRODUCTION, USE, PATENT RIGHTS AND SALES RIGHTS ARE EXPRESSLY RESERVED BY SAMTEC, INC. THIS DOCUMENT SHALL NOT BE DISCLOSED, IN WHOLE OR PART, TO ANY UNAUTHORIZED PERSON OR ENTITY NOR REPRODUCED, TRANSFERRED OR INCORPORATED IN ANY OTHER PROJECT IN ANY MANNER WITHOUT THE EXPRESS WRITTEN CONSENT OF SAMTEC, INC. \*



520 PARK EAST BLVD, NEW ALBANY, IN 47150  
 PHONE: 812-944-6733 FAX: 812-948-5047  
 e-Mail: info@SAMTEC.com code: 55322

SHEET SCALE: 2:1

DESCRIPTION:  
 .050 PITCH SOCKET ARRAY ASSEMBLY

DWG. NO.  
 ASP-134603-01

BY: S SELLE 10/31/2007 SHEET 4 OF 4