

REVISION B

REVISION

| | | |
|------------------------|----|---------|
| 0 | JB | P MASON |
| 4/18/2011 ECN-152533 | | |
| ISSUE FOR REVIEW | | |
| A | JB | P MASON |
| 5/2/2011 ECN-153504 | | |
| RELEASE FOR PRODUCTION | | |
| B | TP | P MASON |
| 8/30/2013 ECN-210746 | | |

NOTES: ADD TO NOTE 6 "FOR QTY'S LESS THAN 125 PCS, NO TRAILER OR LEADER WILL BE SUPPLIED."

- NOTES:
1. 6 ROW, 19 POSITION NOT AVAILABLE AS STANDARD.
 2. REPRESENTS A CRITICAL DIMENSION.
 3. MAXIMUM BURR ALLOWANCE: .00015[.038]
 4. MAXIMUM CUT FLASH: .010[.25]
 5. MAXIMUM ALLOWABLE BOW: TOP/BOTTOM: .006[.15], SIDE/SIDE: .003[.08]
 6. PARTS TO BE PACKAGED IN TAPE & REEL.
FOR QTY'S LESS THAN 125 PCS, NO TRAILER OR LEADER WILL BE SUPPLIED.

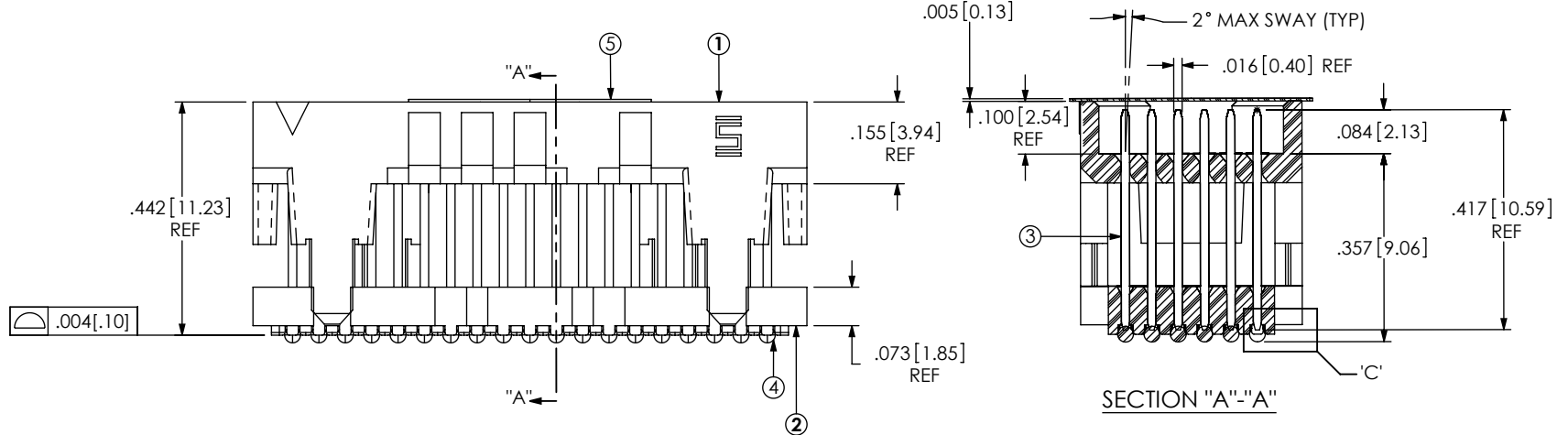
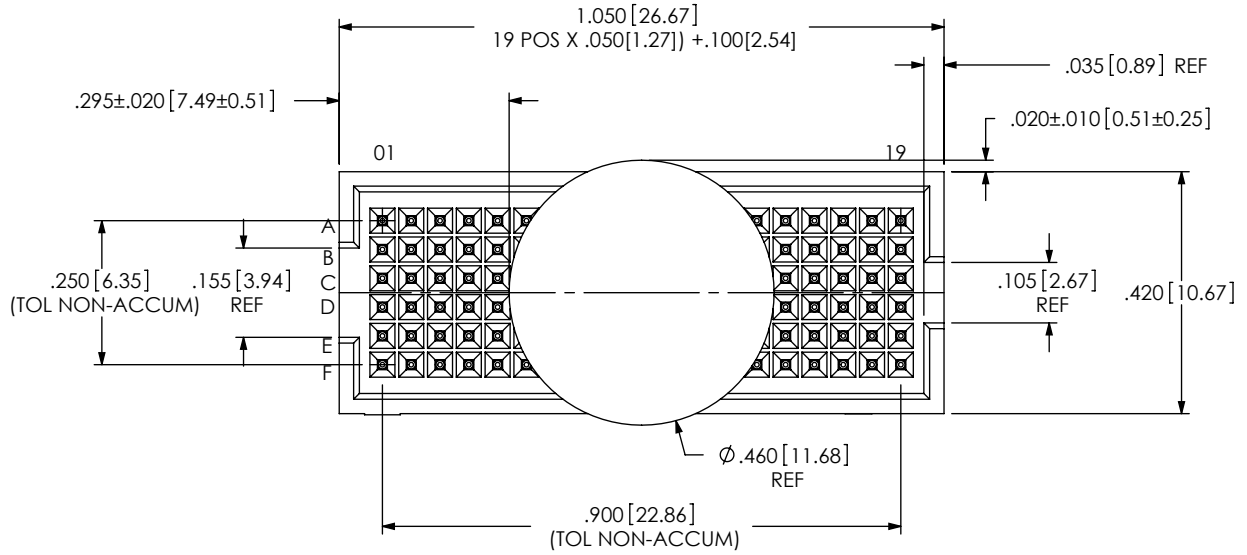
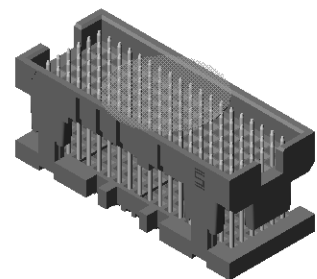

BY SIGNING THIS DOCUMENT YOU ARE ACCEPTING THE CONDITIONS SET WITHIN. YOUR REQUIREMENTS MUST BE LISTED WITHIN THIS DRAWING. WHERE NO DIRECTION FROM THE CUSTOMER IS IDENTIFIED SAMTEC'S PROCESS REQUIREMENTS WILL BE USED.

DATE: _____
 COMPANY: _____
 CUSTOMER SIGNATURE: _____
 PRINTED NAME: _____
 PHONE NO.: _____
 EXCEPTIONS: _____

| ITEM NO. | PART NUMBER | QUANTITY | MATERIAL |
|----------|-----------------|----------|----------------------------|
| 1 | ASP-103598-03-B | 1.0000 | VECTRA E130i, COLOR: BLACK |
| 2 | ASP-103599-01-B | 1.0000 | VECTRA E130i, COLOR: BLACK |
| 3 | T-1R27-12B-H-1 | 114.00 | BRASS ALLOY 260, 3/4 HARD |
| 4 | SDB-030-6337 | 114.00 | 63% Sn / 37% Pb |
| 5 | K-850-650 | .89000 | POLYIMIDE FILM |
| 6 | CT-ASP3112MS | .00571 | ANTI-STATIC BLACK HIPS |

| | | |
|---|--|---|
| UNLESS OTHERWISE SPECIFIED, DIMENSIONS ARE IN INCHES. TOLERANCES ARE: DECIMALS ANGLES .XX: ±.01 2° .XXX: ±.005 .XXXX: ±.0020 | PROPRIETARY NOTE THIS DOCUMENT CONTAINS INFORMATION CONFIDENTIAL AND PROPRIETARY TO SAMTEC, INC. AND SHALL NOT BE REPRODUCED OR TRANSFERRED TO OTHER DOCUMENTS OR DISCLOSED TO OTHERS OR USED FOR ANY PURPOSE OTHER THAN THAT WHICH IT WAS OBTAINED WITHOUT THE EXPRESSED WRITTEN CONSENT OF SAMTEC, INC. |  520 PARK EAST BLVD., NEW ALBANY, IN 47150 PHONE: 812-944-6733 FAX: 812-948-5047 e-Mail: info@SAMTEC.com code 55322 |
| | DO NOT SCALE DRAWING SHEET SCALE: 3:1 PLATING: CONTACT AREA: .000030 GOLD OVER .000050 NICKEL REMAINDER: .000003 GOLD OVER .000050 NICKEL | |

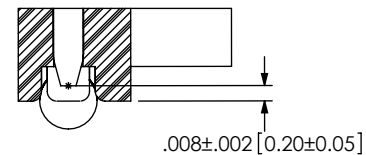
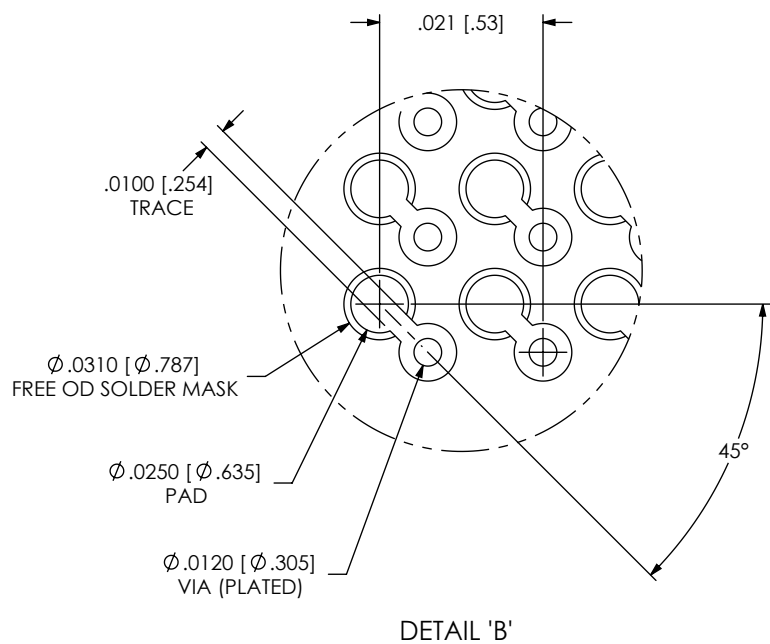
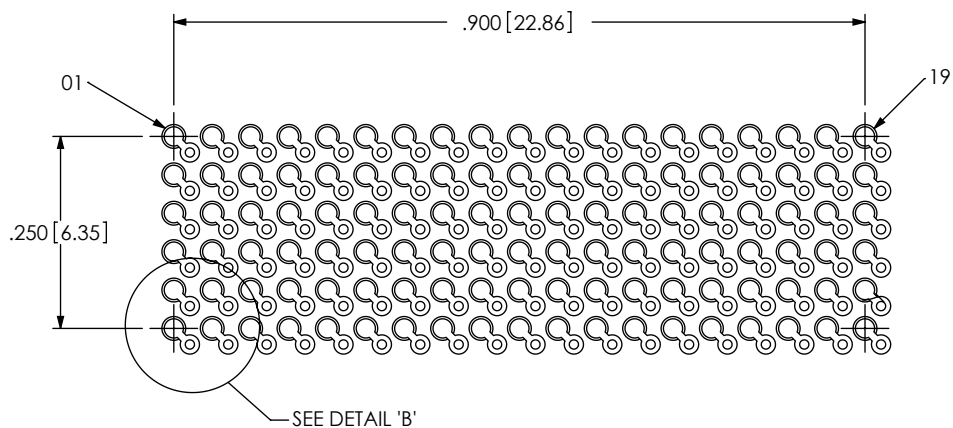

DETAIL 'C'
SCALE 10:1

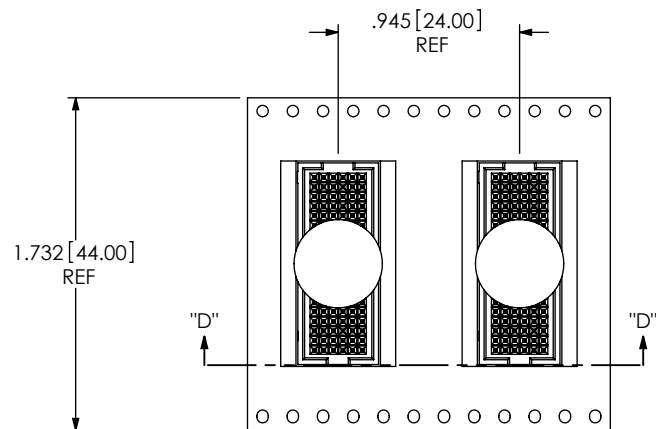

USER DIRECTION OF UN-REELING
POCKET NOT DETAILED →

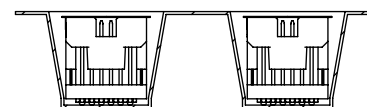

SECTION "D"-"D"
SCALE 1:1

PACKAGING VIEW

PROPRIETARY NOTE

THIS DOCUMENT CONTAINS INFORMATION CONFIDENTIAL AND PROPRIETARY TO SAMTEC, INC. AND SHALL NOT BE REPRODUCED OR TRANSFERRED TO OTHER DOCUMENTS OR DISCLOSED TO OTHERS OR USED FOR ANY PURPOSE OTHER THAN THAT WHICH IT WAS OBTAINED WITHOUT THE EXPRESSED WRITTEN CONSENT OF SAMTEC, INC.



520 PARK EAST BLVD, NEW ALBANY, IN 47150
PHONE: 812-944-6733 FAX: 812-948-5047
e-Mail info@SAMTEC.com code 55322

SHEET SCALE: 3:1

DESCRIPTION: FLEX, Y, Z, .050 TERMINAL ASSEMBLY

DWG. NO. ASP-153860-02