

REVISIONS

0	TV	J HENRY
9/16/2013	ECN-211701	
ISSUE FOR REVIEW		
A	JB	J HENRY
9/20/2013	ECN-212142	
RELEASE FOR PRODUCTION; BOM: CHG ITEM 4 CT-ASP TO CT-ASP4041MS; ADD SHT 2.		

NOTES:

- 23 POSITIONS NOT AVAILABLE AS STANDARD.
- CX-XX REPRESENTS A CRITICAL DIMENSION.
- MINIMUM PUSHOUT FORCE: 2.22N(.5 LB).
- TO BE MEASURED USING GAGE PINS.
- PARTS TO BE PACKAGEG IN TAPE & REEL.

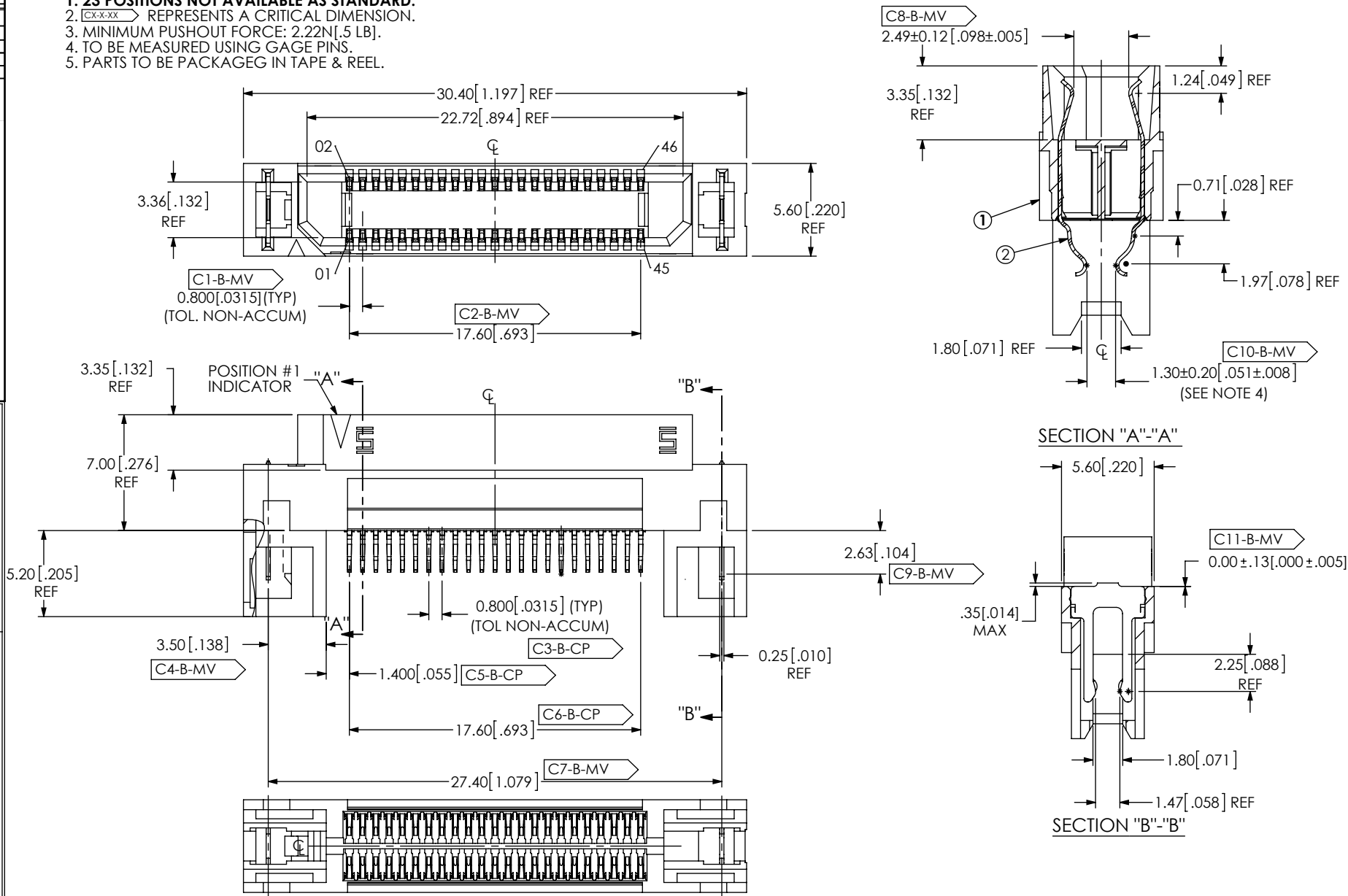

BY SIGNING THIS DOCUMENT YOU ARE ACCEPTING THE CONDITIONS SET WITHIN. YOUR REQUIREMENTS MUST BE LISTED WITHIN THIS DRAWING. WHERE NO DIRECTION FROM THE CUSTOMER IS IDENTIFIED SAMTEC'S PROCESS REQUIREMENTS WILL BE USED.

DATE: _____
 COMPANY: _____
 CUSTOMER SIGNATURE: _____
 PRINTED NAME: _____
 PHONE NO: _____
 EXCEPTIONS: _____

ITEM NO.	PART NUMBER	QUANTITY	MATERIAL
1	ERF8-023-D-EM2	1.0000	VECTRA E130i, COLOR: BLACK
2	C-221-01-S	46.000	BeCu, ALLOY 390 HT
3	WT-17-01-T	2.0000	PHOS BRONZE, 510 SPRING TEMPER
4	CT-ASP4041MS	.00444	CONDUCTIVE POLYMER

A

UNLESS OTHERWISE SPECIFIED, DIMENSIONS ARE IN INCHES. TOLERANCES ARE:
 DECIMALS ANGLES
 .XX: ±.01 [.3] 2°
 .XXX: ±.005 [.13]
 .XXXX: ±.0020 [.051]

PROPRIETARY NOTE
 THIS DOCUMENT CONTAINS INFORMATION CONFIDENTIAL AND PROPRIETARY TO SAMTEC, INC. AND SHALL NOT BE REPRODUCED OR TRANSFERRED TO OTHER DOCUMENTS OR DISCLOSED TO OTHERS OR USED FOR ANY PURPOSE OTHER THAN THAT WHICH IT WAS OBTAINED WITHOUT THE EXPRESSED WRITTEN CONSENT OF SAMTEC, INC.

samtec
 520 PARK EAST BLVD, NEW ALBANY, IN 47150
 PHONE: 812-944-6733 FAX: 812-948-5047
 e-Mail: info@SAMTEC.com code 53322

DO NOT SCALE DRAWING SHEET SCALE: 3:1
 PLATING:
 CONTACTS:
 CONTACT AREA: .000030 GOLD OVER .000050 NICKEL
 REMAINDER: .000200 REF TIN OVER .000050 NICKEL.
 WELD TABS:
 ENTIRE TAB: .000200 REF TIN OVER .000050 NICKEL

DESCRIPTION: MODIFIED ERF8 ASSEMBLY
 DWG. NO. ASP-177706-03
 BY: WHELAN 09/16/2013 SHEET 1 OF 2

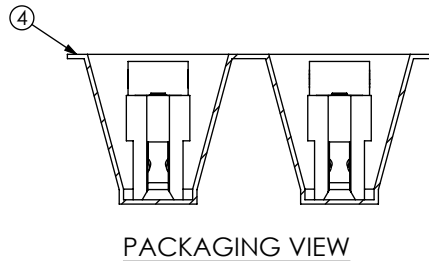
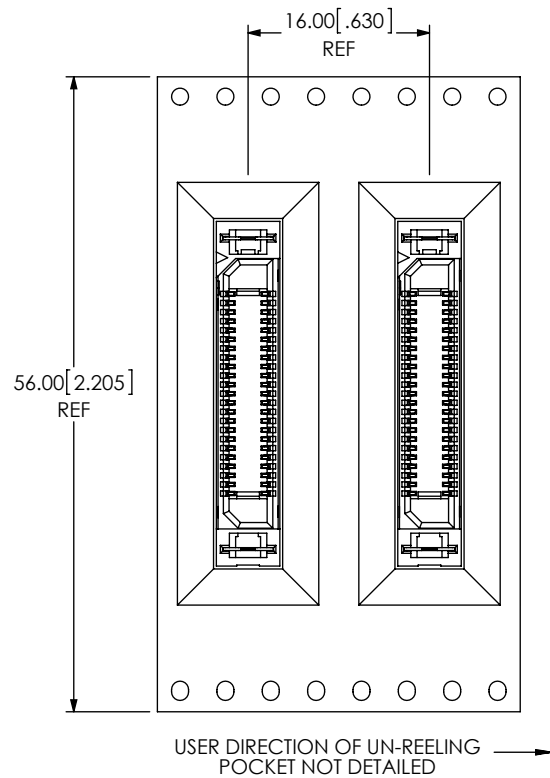

PROPRIETARY NOTE

THIS DOCUMENT CONTAINS INFORMATION
CONFIDENTIAL AND PROPRIETARY TO
SAMTEC, INC. AND SHALL NOT BE REPRODUCED
OR TRANSFERRED TO OTHER DOCUMENTS OR
DISCLOSED TO OTHERS OR USED FOR ANY
PURPOSE OTHER THAN THAT WHICH IT WAS
OBTAINED WITHOUT THE EXPRESSED WRITTEN
CONSENT OF SAMTEC, INC.



520 PARK EAST BLVD., NEW ALBANY, IN 47150
PHONE: 812-944-6733 FAX: 812-948-5047
e-Mail info@SAMTEC.com code 55322

SHEET SCALE: 3:2

DESCRIPTION:
MODIFIED ERF8 ASSEMBLY

DWG. NO.
ASP-177706-03

BY: WHELAN 09/16/2013 SHEET 2 OF 2