

DO NOT SCALE FROM THIS PRINT

AW-XX-03-X-D-XXX-XXX-XX

No OF POSITIONS
-05 THRU -90
(PER ROW)

LEAD STYLE
-03: (SEE NOTE 10)

PLATING SPECIFICATION

-G: LIGHT GOLD
.000010 GOLD CONTACT AREA,
.000003 GOLD TAIL

ROW SPECIFICATION
-D: DOUBLE ROW VERTICAL
(SEE NOTE 4)

SPACE OPTION
"A": .230[5.84] MAX
w/.075[1.91] POST
*.122[3.09] MIN

OPTION

-P: PICK & PLACE PAD
(8 POS MIN, SEE FIG 2, SHT 2)
(USE PPP-37-NT w/ -TR OPTION)
(USE PPP-37 w/ TUBE PKG)
-ES: END SHROUD
(SNAP-ON, 11 POS MIN, SEE NOTE 5,
SEE FIG 8, SHT 3)
(MOLDED, 5 POS MIN SEE FIG 7, SHT 3)
-EP: END SHROUD w GUIDE POST
(11 POS MIN, SEE NOTE 5, SEE FIG 4, SHT 2)
-A: ALIGNMENT PIN
(MOLDED, 4 POS MIN, SEE FIG 5, SHT 2)
(MOLDED NOT AVAILABLE ON ALL POSITIONS)
(STAKED, 7 POS MIN, SEE NOTE 6,
SEE FIG 6, SHT 2)
-TR: TAPE & REEL (84 POS MAX)

POST HEIGHT
.075[1.91] MIN
POST + SPACE = .305[7.75] MAX

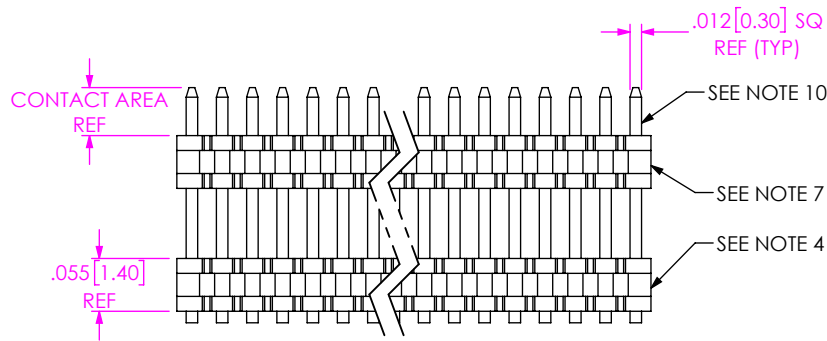
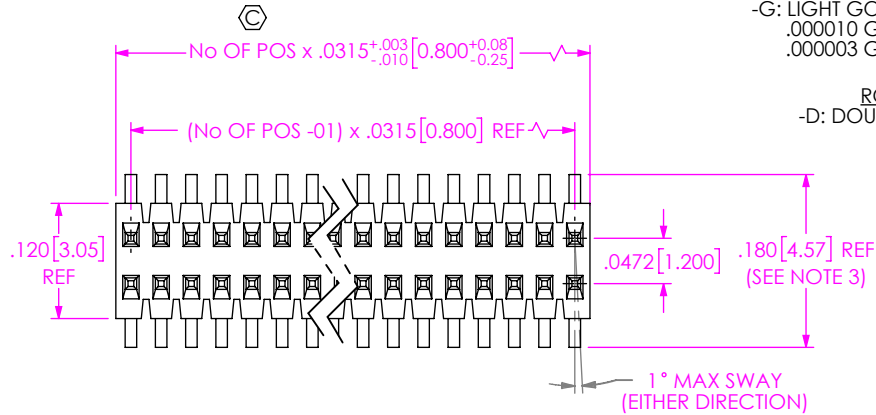

05-40 POS	.004[0.10]
41-90 POS	.006[0.15]

.030[0.76] (SEE NOTE 3)

NOTES:

1. REPRESENTS A CRITICAL DIMENSION.
2. MINIMUM PUSHOUT FORCE: 1.0 LBF
3. TAILS TO BE SHEARED TO DIMENSION SHOWN.
4. BOTTOM BODY FOR AUTOMATION AND .122 SPACE OPTION, USE FTE-90-D-A;
BOTTOM BODY FOR AUTOMATION AND OTHER SPACE OPTIONS, USE AW-90-D-A;
BOTTOM BODY FOR HANDFILL AND ALL SPACE OPTIONS, USE FTE-90-D-A.
AUTOMATION/HANDFILL PROCESS OPTION IS CHOSEN AT SAMTEC'S DISCRETION.
5. FOR USE WITH .075[1.91] POST HEIGHT ONLY.
6. FOR USE WITH BOARD STACKS .160-.230[4.06-5.84] ONLY.
7. TOP BODY USE FTE-90-D.
8. MAXIMUM CUT FLASH: .010[0.25]
9. NOTE DELETED.
10. FOR MACHINE FILLED, USE T-1S29-02-X;
FOR HAND FILLED, USE T-1S29-04-X
11. FOR ADDED MECHANICAL STABILITY, SAMTEC RECOMMENDS MECHANICAL BOARD SPACERS BE USED IN APPLICATIONS WITH GOLD OR SELECTIVE GOLD PLATED CONNECTORS.
CONTACT IPG@SAMTEC.COM FOR MORE INFORMATION.

FIG 1
AW-XX-03-X-D-XXX-XXX SHOWN

UNLESS OTHERWISE SPECIFIED, DIMENSIONS ARE IN INCHES.
TOLERANCES ARE:
DECIMALS ANGLES
.XX: ±.01 [0.3] 2°
.XXX: ±.005 [0.13]
.XXXX: ±.0020 [0.051]

PROPRIETARY NOTE
THIS DOCUMENT CONTAINS CONFIDENTIAL AND PROPRIETARY INFORMATION AND ALL DESIGN, MANUFACTURING, REPRODUCTION, USE, PATENT RIGHTS AND SALES RIGHTS ARE EXPRESSLY RESERVED BY SAMTEC, INC. THIS DOCUMENT SHALL NOT BE DISCLOSED, IN WHOLE OR PART, TO ANY UNAUTHORIZED PERSON OR ENTITY NOR REPRODUCED, TRANSFERRED OR INCORPORATED IN ANY OTHER PROJECT IN ANY MANNER WITHOUT THE EXPRESS WRITTEN CONSENT OF SAMTEC, INC.

MATERIAL: DO NOT SCALE DRAWING SHEET SCALE: 5:1
INSULATOR:
FTE-90-D-XX: VECTRA E130i, COLOR: BLACK or ZENITE 6130L, COLOR: BLACK
AW-90-D-A: ZENITE 6130L, COLOR: NATURAL
TERMINAL: PHOS BRONZE
F:\DWG\MISC\MKTG\AW-XX-03-X-D-XXX-XXX-MKT.SLDDRW



520 PARK EAST BLVD, NEW ALBANY, IN 47150
PHONE: 812-944-6733 FAX: 812-948-5047
e-Mail info@SAMTEC.com code 55322

DESCRIPTION:
0.8mm X 1.2mm CL TERMINAL STRIP ASM
DWG. NO.
AW-XX-03-X-D-XXX-XXX-XX
BY: PURVIS 12/14/1995 SHEET 1 OF 3

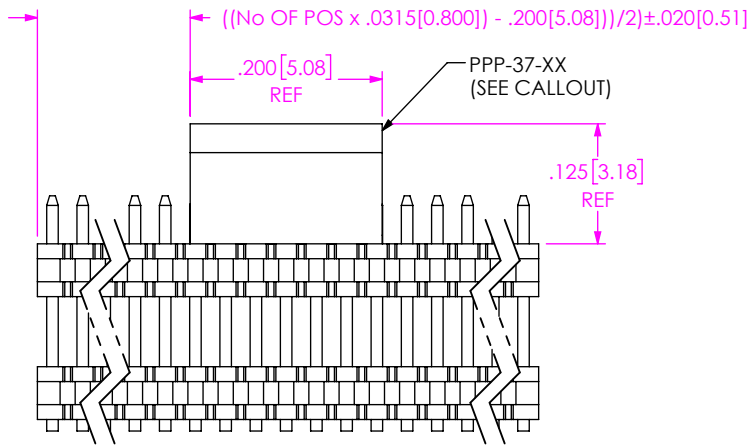

FIG 2
-P OPTION
AW-XX-03-X-D-XXX-XXX-P SHOWN
(SAME AS FIG 1, EXCEPT AS SHOWN)
8 POS MIN

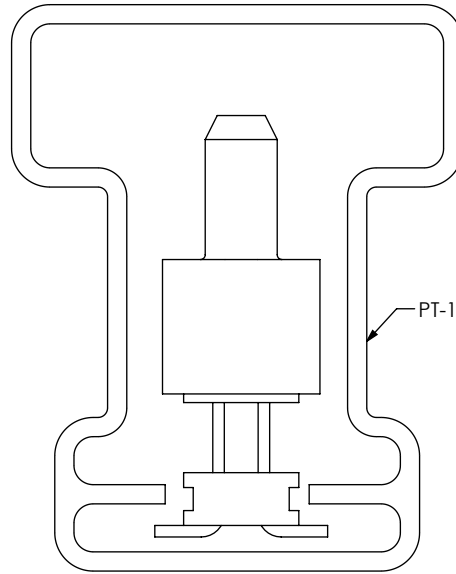

FIG 3
PACKAGING VIEWS

TABLE 1			
OPTIONS	POST + SPACE	TUBE	PLUG
NONE, -A	> .285	PT-FTE001-DV-P	TP-09
-P, -A-P, -ES-P	> .265	PT-1-24-02-60	TP-03
-EP	ALL	PT-1-24-02-44	TP-03
NONE, -A, -ES	<= .285	PT-FTE001-DV-P	TP-09
-P, -A-P, -ES-P	<= .265	PT-FTE001-DV-P	TP-09
-ES	> .285	PT-1-24-02-60	TP-03

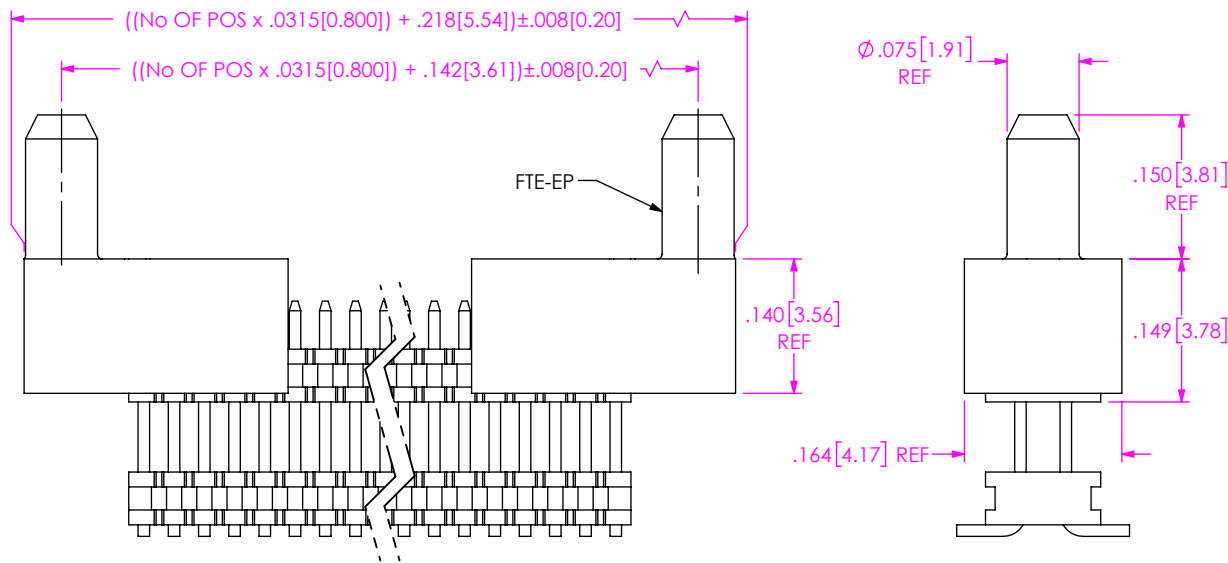

FIG 4
-EP OPTION
AW-XX-03-X-D-XXX-XXX-EP SHOWN
(SAME AS FIG 1, EXCEPT AS SHOWN)
POST HEIGHT MUST BE .075[1.91]

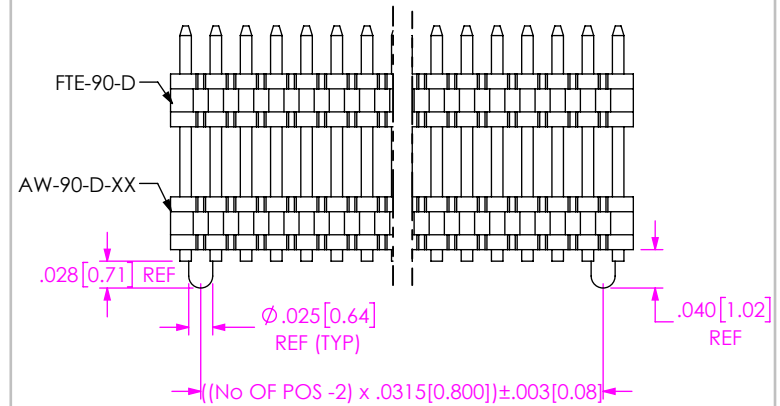

FIG 5
-A OPTION (MOLDED)
AW-XX-03-X-D-XXX-XXX-A SHOWN
(SAME AS FIG 1, EXCEPT AS SHOWN)
4 POS MIN

PROPRIETARY NOTE
THIS DOCUMENT CONTAINS CONFIDENTIAL AND PROPRIETARY INFORMATION AND ALL DESIGN, MANUFACTURING, REPRODUCTION, USE, PATENT RIGHTS AND SALES RIGHTS ARE EXPRESSLY RESERVED BY SAMTEC, INC. THIS DOCUMENT SHALL NOT BE DISCLOSED, IN WHOLE OR PART, TO ANY UNAUTHORIZED PERSON OR ENTITY NOR REPRODUCED, TRANSFERRED OR INCORPORATED IN ANY OTHER PROJECT IN ANY MANNER WITHOUT THE EXPRESS WRITTEN CONSENT OF SAMTEC, INC.



520 PARK EAST BLVD, NEW ALBANY, IN 47150
PHONE: 812-944-6733 FAX: 812-948-5047
e-Mail info@SAMTEC.com code 55322

DO NOT SCALE DRAWING

SHEET SCALE: 5:1

DESCRIPTION:
0.8mm X 1.2mm CL TERMINAL STRIP ASM

DWG. NO.
AW-XX-03-X-D-XXX-XXX-XX

BY: PURVIS 12/14/1995 SHEET 2 OF 3

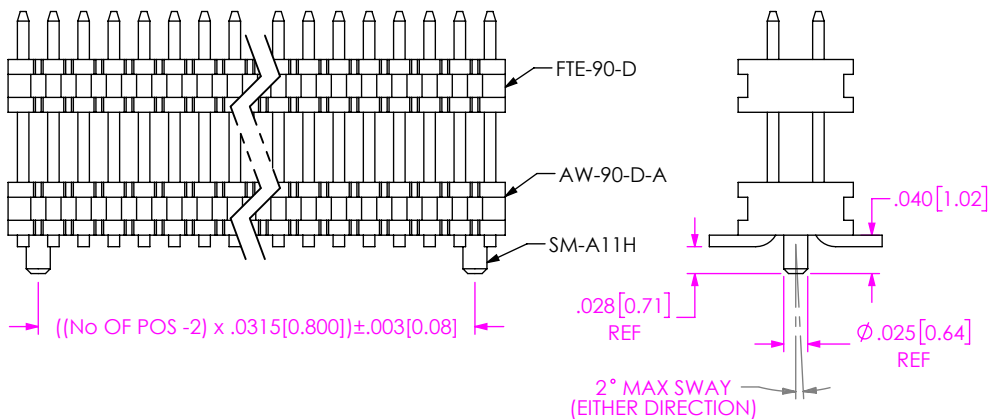

FIG 6
-A OPTION (STAKED)
 AW-XX-03-X-D-XXX-XXX-A SHOWN
 (SAME AS FIG 1, EXCEPT AS SHOWN)
 7 POS MIN

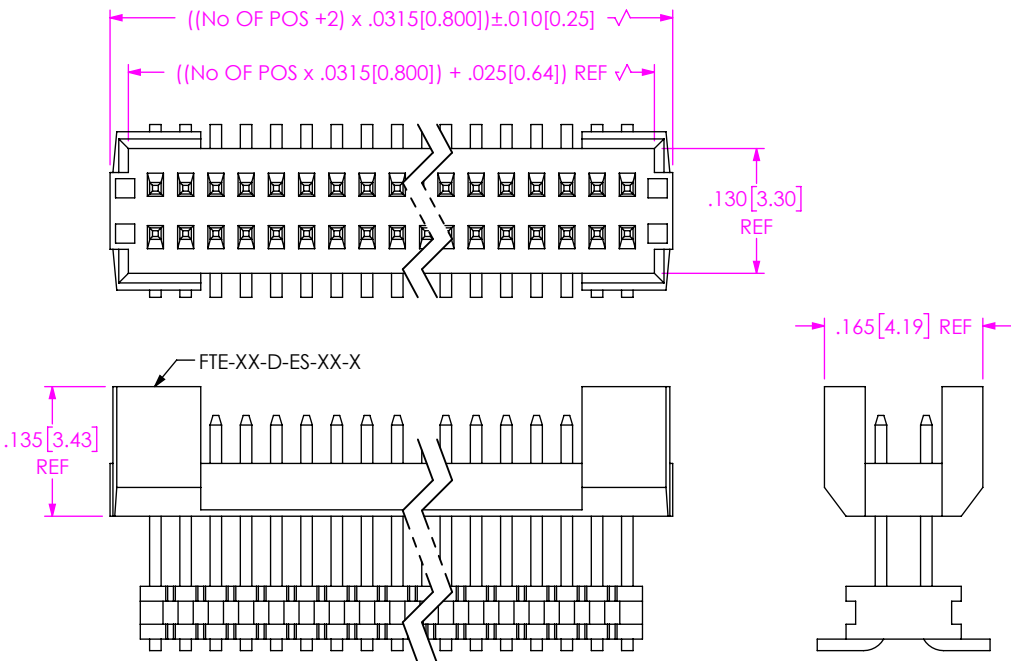

FIG 7
-ES OPTION (MOLDED)
 AW-XX-03-X-D-XXX-XXX-ES SHOWN
 (SAME AS FIG 1, EXCEPT AS SHOWN)
 5 POS MIN

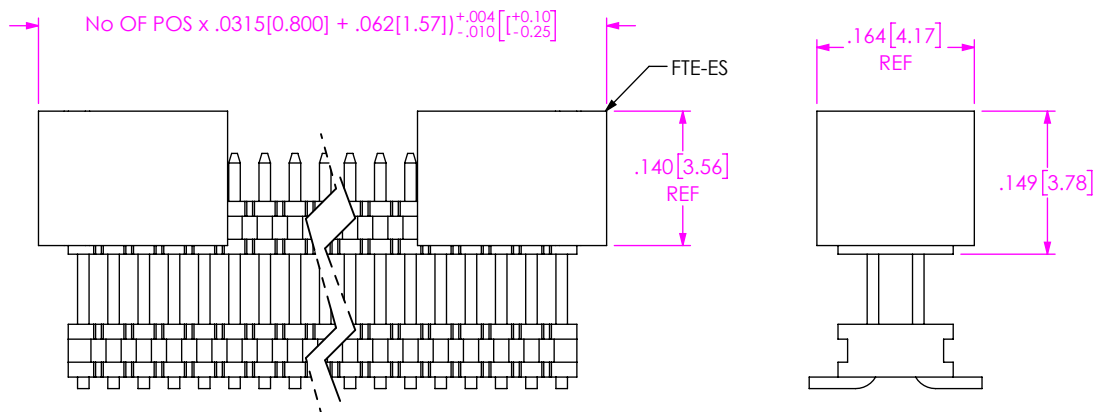

FIG 8
-ES OPTION (SNAP ON)
 AW-XX-03-X-D-XXX-XXX-ES SHOWN
 (SAME AS FIG 1, EXCEPT AS SHOWN)
 POST HEIGHT MUST BE .075[1.91]

PROPRIETARY NOTE
 THIS DOCUMENT CONTAINS CONFIDENTIAL AND PROPRIETARY INFORMATION AND ALL DESIGN, MANUFACTURING, REPRODUCTION, USE, PATENT RIGHTS AND SALES RIGHTS ARE EXPRESSLY RESERVED BY SAMTEC, INC. THIS DOCUMENT SHALL NOT BE DISCLOSED, IN WHOLE OR PART, TO ANY UNAUTHORIZED PERSON OR ENTITY NOR REPRODUCED, TRANSFERRED OR INCORPORATED IN ANY OTHER PROJECT IN ANY MANNER WITHOUT THE EXPRESS WRITTEN CONSENT OF SAMTEC, INC.



520 PARK EAST BLVD, NEW ALBANY, IN 47150
 PHONE: 812-944-6733 FAX: 812-948-5047
 e-Mail info@SAMTEC.com code 55322

DO NOT SCALE DRAWING

SHEET SCALE: 5:1

DESCRIPTION:
 0.8mm X 1.2mm CL TERMINAL STRIP ASM

DWG. NO.
AW-XX-03-X-D-XXX-XXX-XX

BY: PURVIS 12/14/1995 SHEET 3 OF 3