

DO NOT SCALE FROM THIS PRINT

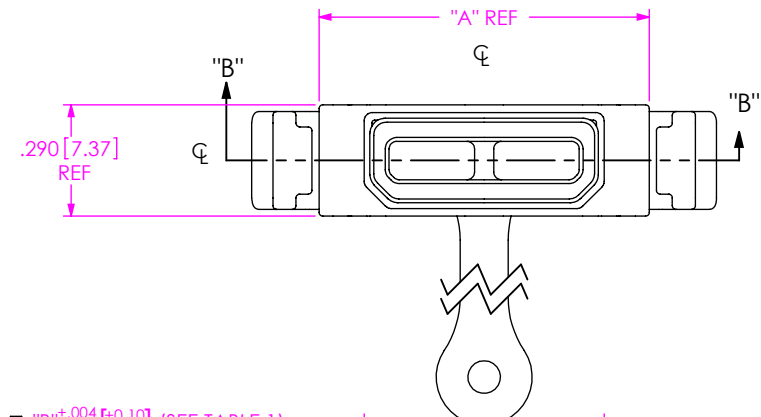

No. OF POSITIONS  
-10, -15, & -20  
(PER ROW)

OPTION  
-01: W/STRAP

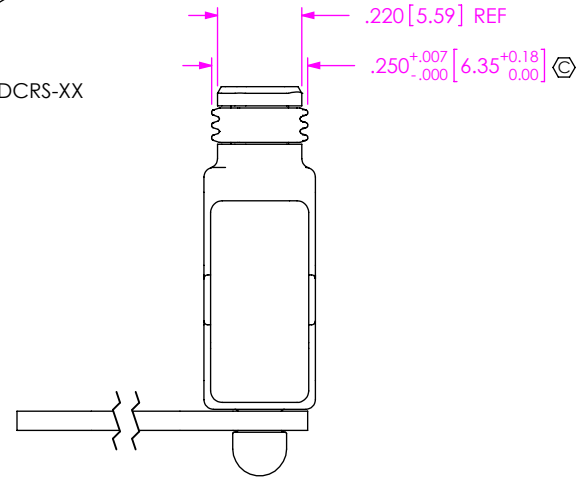
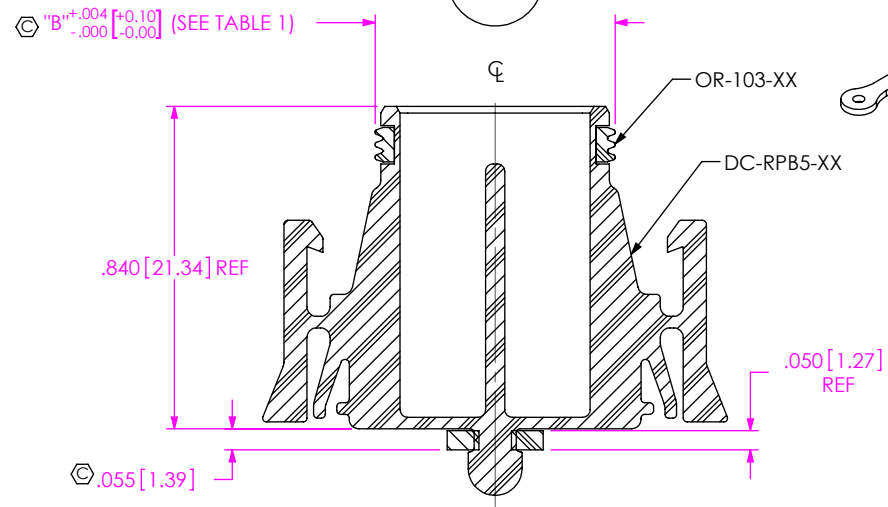
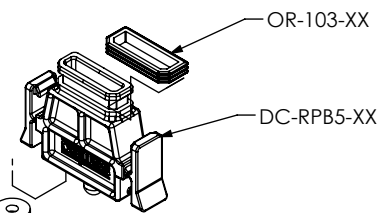

SECTION "B"-"B"  
SCALE 2 : 1

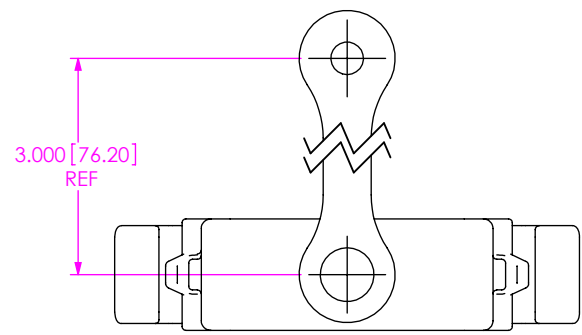

FIG. 1  
DCA-RPB5-T0-01 SHOWN

- NOTES:
1. Ⓢ REPRESENTS A CRITICAL DIMENSION.
  2. COMPONENTS OF SUB-ASSEMBLY TO BE INSPECTED USING COMPONENT PRINTS.
  3. MINIMUM RETENTION: 1.0 LB. [4.4N].

TABLE 1		
No. OF POS.	"A"	"B"
-10	.860 [21.84]	.625 [15.88]
-15	1.110 [28.19]	.875 [22.23]
-20	1.360 [34.54]	1.125 [28.58]

UNLESS OTHERWISE SPECIFIED, DIMENSIONS ARE IN INCHES. TOLERANCES ARE:

DECIMALS	ANGLES
.XX: ±.01 [0.3]	2°
.XXX: ±.005 [0.13]	
.XXXX: ±.0020 [0.051]	

PROPRIETARY NOTE  
THIS DOCUMENT CONTAINS INFORMATION CONFIDENTIAL AND PROPRIETARY TO SAMTEC, INC. AND SHALL NOT BE REPRODUCED OR TRANSFERRED TO OTHER DOCUMENTS OR DISCLOSED TO OTHERS OR USED FOR ANY PURPOSE OTHER THAN THAT WHICH IT WAS OBTAINED WITHOUT THE EXPRESSED WRITTEN CONSENT OF SAMTEC, INC.



520 PARK EAST BLVD., NEW ALBANY, IN 47150  
PHONE: 812-944-6733 FAX: 812-948-5047  
e-Mail info@SAMTEC.com code 55322

MATERIAL: DO NOT SCALE DRAWING SHEET SCALE: 2:1  
CAP: PA66  
STRAP: NATURAL RUBBER  
O-RING: NBR

DESCRIPTION: DUST CAP FOR RPB5

DWG. NO. DCA-RPB5-XX-01

BY: ROY LUO 9/29/2010 SHEET 1 OF 1