

DO NOT SCALE FROM THIS PRINT

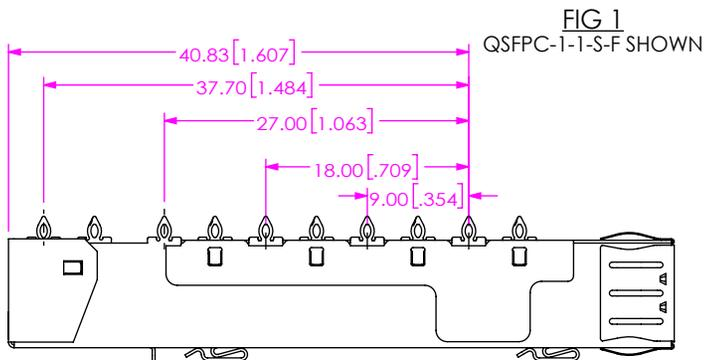
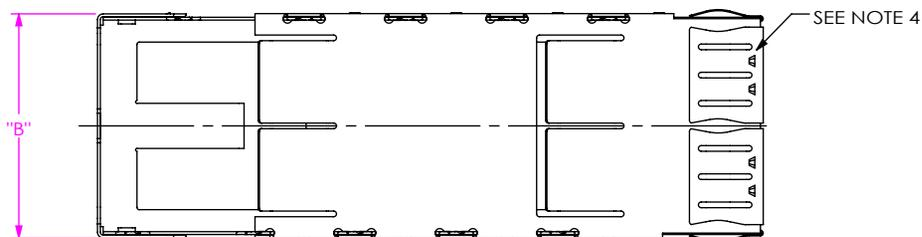
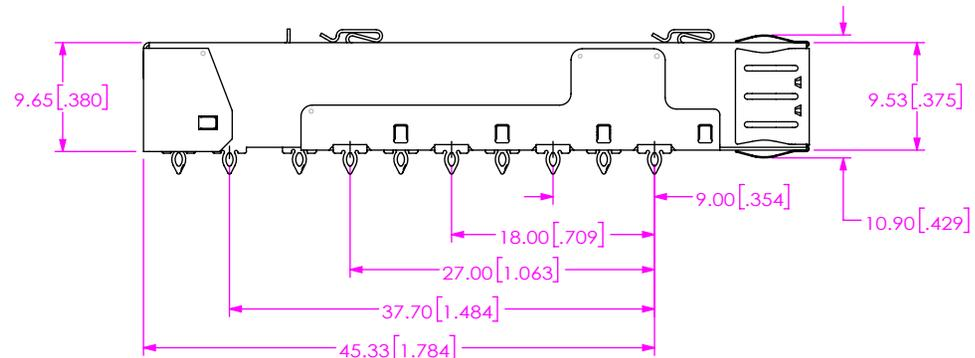
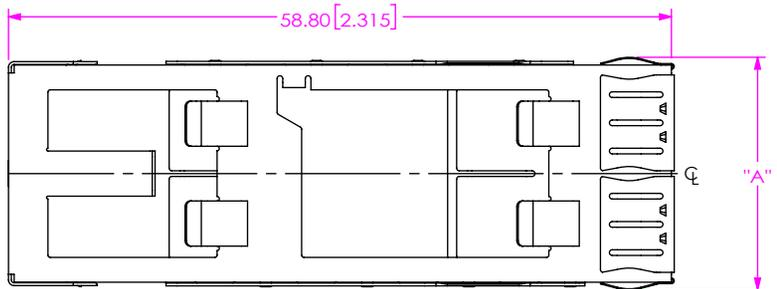

- NOTES:
1. REPRESENTS A CRITICAL DIMENSION.
  2. NOTED DELETED.
  3. PULL AND SHIP PARTS IN TRAY, SEE TABLE 3.
  4. EMI FINGERS WELDED IN CENTER AS SHOWN EXCEPT ON -N OPTION.

QSFP-C-X-X-X-XX-F

FUTURE STACKED CAGES

- 1: SINGLE HIGH
- 2: DOUBLE

NO. OF PORTS

- 1, -2, -3, -4
- 5, -6

FLYOVER

(SEE TABLE 2)  
(LEAVE BLANK FOR NON FLYOVER)  
-F: FLYOVER

OPTIONS

(SEE TABLE 2)  
(LEAVE BLANK FOR NO LIGHT PIPES)  
-LP: LIGHTPIPE  
-N : NO HEAT SINK CLOSED TOP  
(SEE FIG 7)

EMI PANEL OPTION

(SEE TABLE 2)  
-S: SPRING FINGERS  
-T: THROUGH BEZEL W/EMI GASKET

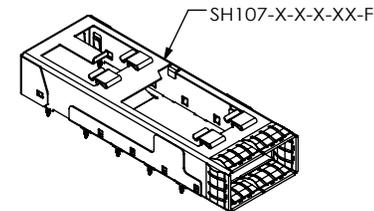
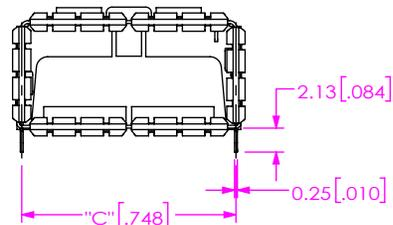

TABLE 2

EMI PANEL OPTION	OPTIONS	FLYOVER	FUTURE STACKED CAGES												
			-1: SINGLE HIGH						-2: DOUBLE						
			NO. OF PORTS												
			1	2	3	4	5	6	1	2	3	4	5	6	
-S: SPRING FINGERS	BLANK	BLANK		X	X	X	X	X							
		-F		X	X	X	X	X							
	-LP	BLANK	X	X	X	X	X	X							
		-F		X	X	X	X	X							
-N	BLANK		X	X	X	X	X								
	-F		X	X	X	X	X								
-T: THROUGH BEZEL W/EMI GASKET	BLANK	BLANK													
		-F													
	-LP	BLANK													
		-F													
-N	BLANK														
	-F														

X= NOT TOOLED, = RELEASED, = NOT RELEASED

TABLE 1

NO. OF PORTS	"A"	"B"	"C"
-1	20.62 [0.812]	19.85 [0.781]	19.00 [0.748]
-2	39.62 [1.560]	38.85 [1.530]	38.00 [1.496]
-3	58.62 [2.308]	57.85 [2.278]	57.00 [2.244]
-4	77.62 [3.056]	76.85 [3.026]	76.00 [2.992]
-5	96.62 [3.804]	95.85 [3.774]	95.00 [3.740]
-6	115.62 [4.552]	114.85 [4.522]	114.00 [4.488]

**PROPRIETARY NOTE**  
THIS DOCUMENT CONTAINS CONFIDENTIAL AND PROPRIETARY INFORMATION AND ALL DESIGN, MANUFACTURING, REPRODUCTION, USE, PATENT RIGHTS AND SALES RIGHTS ARE EXPRESSLY RESERVED BY SAMTEC, INC. THIS DOCUMENT SHALL NOT BE DISCLOSED, IN WHOLE OR PART, TO ANY UNAUTHORIZED PERSON OR ENTITY NOR REPRODUCED, TRANSFERRED OR INCORPORATED IN ANY OTHER PROJECT IN ANY MANNER WITHOUT THE EXPRESS WRITTEN CONSENT OF SAMTEC, INC.

SHEET SCALE: 3:2  
DO NOT SCALE DRAWING

CAGE: 7025, TM03  
EMI FINGERS: STAINLESS STEEL SUS304

520 PARK EAST BLVD, NEW ALBANY, IN 47150  
PHONE: 812-944-6733 FAX: 812-948-5047  
e-Mail info@SAMTEC.com code 55322

DESCRIPTION:  
**FQSFP CAGE ASSEM**  
**QSFP-C-X-X-X-XX-F**

DWG. NO.

BY: JOE Z 06/20/2017 SHEET 1 OF 6

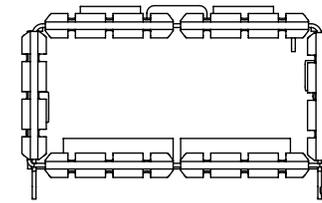
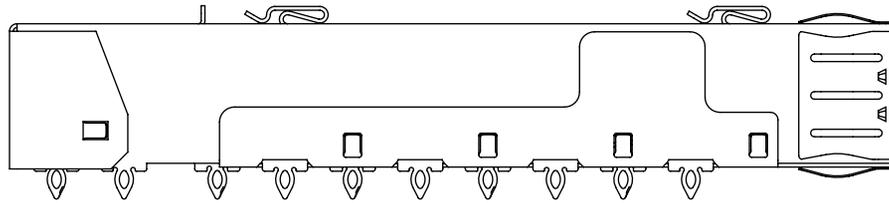

FIG 2  
 QSFP-1-1-S SHOWN  
 (DIFFERENT AS SHOWN, OTHERWISE SAME AS FIG 1)

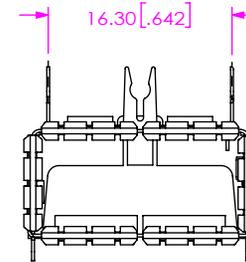
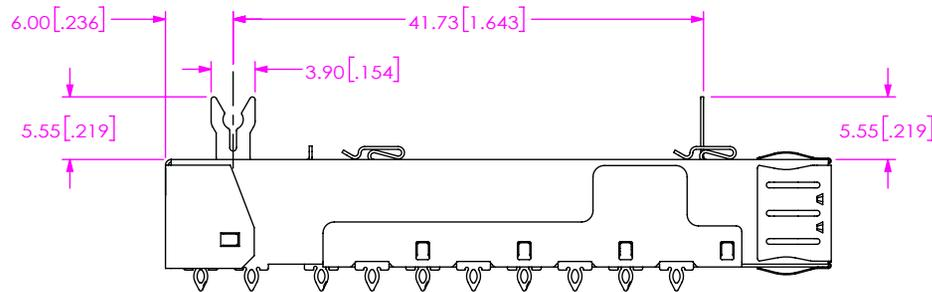
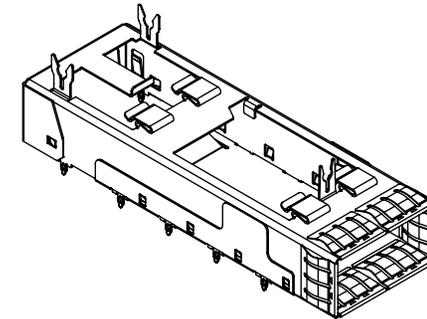
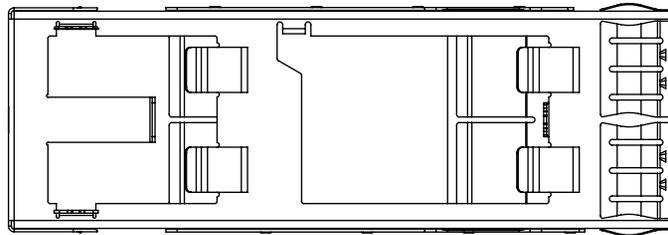

FIG 3  
 QSFP-1-1-S-LP-F SHOWN  
 (DIFFERENT AS SHOWN, OTHERWISE SAME AS FIG 1)

PROPRIETARY NOTE  
 THIS DOCUMENT CONTAINS CONFIDENTIAL AND PROPRIETARY INFORMATION AND ALL DESIGN, MANUFACTURING, REPRODUCTION, USE, PATENT RIGHTS AND SALES RIGHTS ARE EXPRESSLY RESERVED BY SAMTEC, INC. THIS DOCUMENT SHALL NOT BE DISCLOSED, IN WHOLE OR PART, TO ANY UNAUTHORIZED PERSON OR ENTITY NOR REPRODUCED, TRANSFERRED OR INCORPORATED IN ANY OTHER PROJECT IN ANY MANNER WITHOUT THE EXPRESS WRITTEN CONSENT OF SAMTEC, INC.

SHEET SCALE: 1:1

**samtec**

520 PARK EAST BLVD, NEW ALBANY, IN 47150  
 PHONE: 812-944-6733 FAX: 812-948-5047  
 e-Mail info@SAMTEC.com code 55322

DESCRIPTION:  
 FQSFP CAGE ASSEM  
 DWG. NO.  
 QSFP-1-1-S-LP-F

BY: JOE Z 06/20/2017 SHEET 2 OF 6

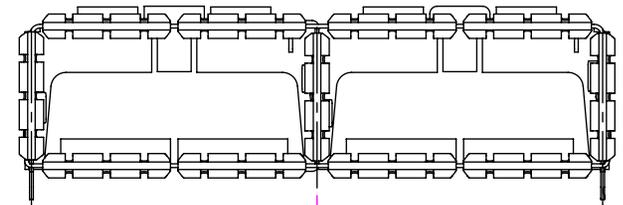
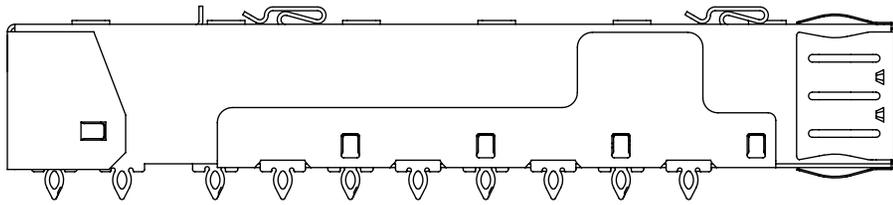

19.00

"C"

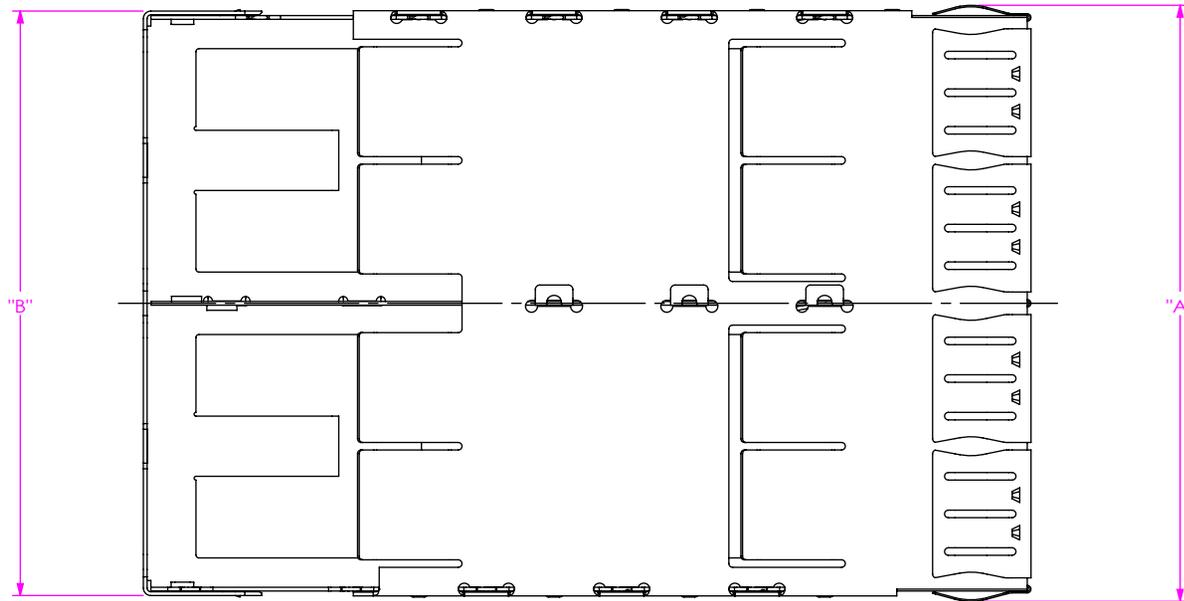

FIG 4  
 QSFP-1-2-S-F SHOWN  
 (DIFFERENT AS SHOWN, OTHERWISE SAME AS FIG 1)

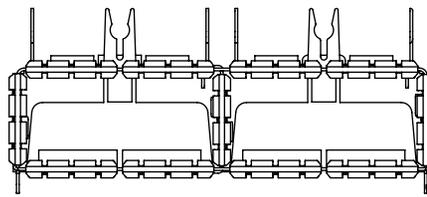
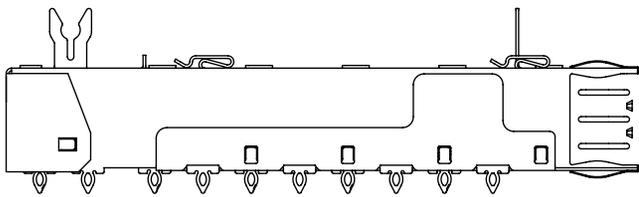

FIG 6  
 QSFP-1-2-S-LP-F SHOWN  
 (DIFFERENT AS SHOWN, OTHERWISE SAME AS FIG 3 & 4)  
 (NOT TOOLED)

F:\DWG\MISC\MKTG\QSFP-X-X-X-XX-F-MKT.SLDDRW

**PROPRIETARY NOTE**  
 THIS DOCUMENT CONTAINS CONFIDENTIAL AND PROPRIETARY INFORMATION AND ALL DESIGN, MANUFACTURING, REPRODUCTION, USE, PATENT RIGHTS AND SALES RIGHTS ARE EXPRESSLY RESERVED BY SAMTEC, INC. THIS DOCUMENT SHALL NOT BE DISCLOSED, IN WHOLE OR PART, TO ANY UNAUTHORIZED PERSON OR ENTITY NOR REPRODUCED, TRANSFERRED OR INCORPORATED IN ANY OTHER PROJECT IN ANY MANNER WITHOUT THE EXPRESS WRITTEN CONSENT OF SAMTEC, INC.



520 PARK EAST BLVD, NEW ALBANY, IN 47150  
 PHONE: 812-944-6733 FAX: 812-948-5047  
 e-Mail info@SAMTEC.com code 55322

SHEET SCALE: 1:1

DESCRIPTION:  
 FQSFP CAGE ASSEM

DWG. NO.  
 QSFP-X-X-X-XX-F

BY: JOE Z 06/20/2017 SHEET 3 OF 6

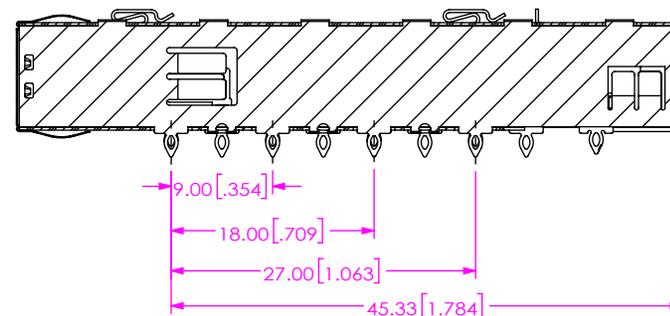
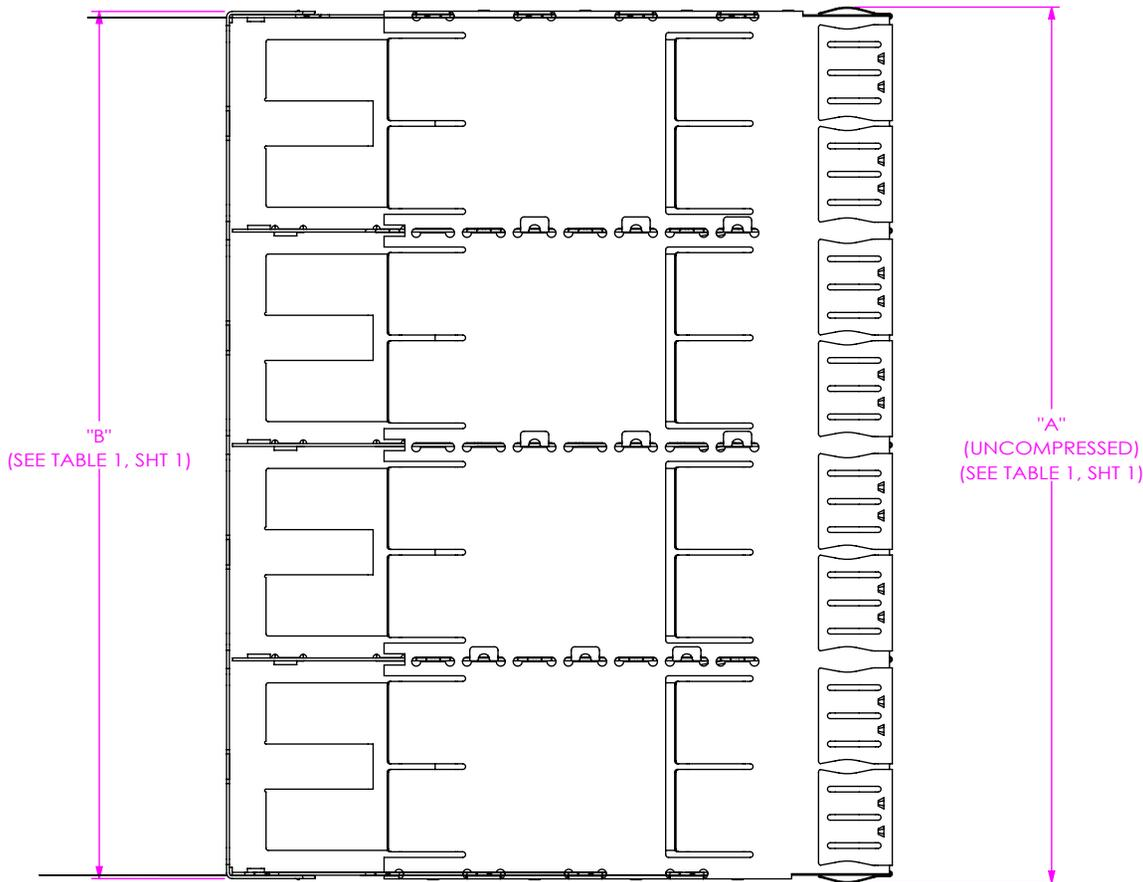
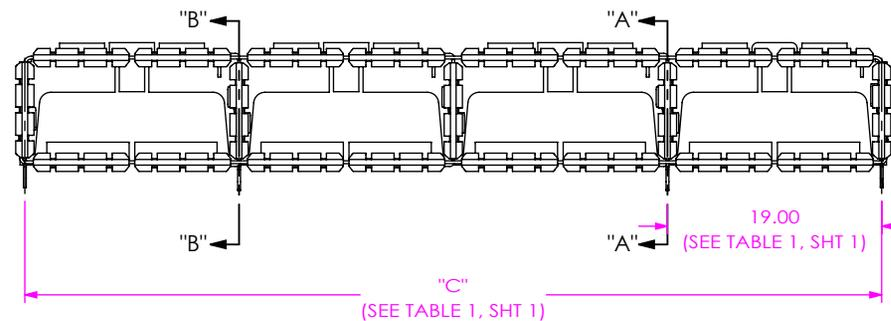
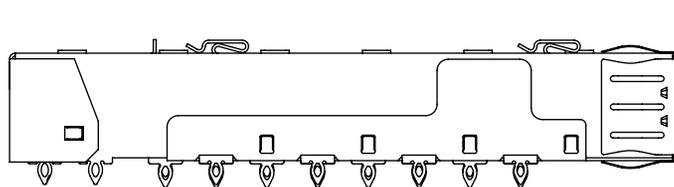

SECTION "A"-"A"  
SCALE 1.5 : 1

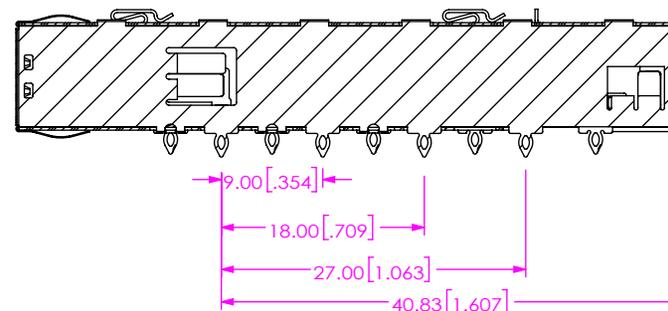

SECTION "B"-"B"  
SCALE 1.5 : 1

FIG 5  
QSFP-1-4-S-F SHOWN  
(DIFFERENT AS SHOWN, OTHERWISE SAME AS FIG 4)

PROPRIETARY NOTE

THIS DOCUMENT CONTAINS CONFIDENTIAL AND PROPRIETARY INFORMATION AND ALL DESIGN, MANUFACTURING, REPRODUCTION, USE, PATENT RIGHTS AND SALES RIGHTS ARE EXPRESSLY RESERVED BY SAMTEC, INC. THIS DOCUMENT SHALL NOT BE DISCLOSED, IN WHOLE OR PART, TO ANY UNAUTHORIZED PERSON OR ENTITY NOR REPRODUCED, TRANSFERRED OR INCORPORATED IN ANY OTHER PROJECT IN ANY MANNER WITHOUT THE EXPRESS WRITTEN CONSENT OF SAMTEC, INC.



520 PARK EAST BLVD, NEW ALBANY, IN 47150  
PHONE: 812-944-6733 FAX: 812-948-5047  
e-Mail: info@SAMTEC.com code 55322

SHEET SCALE: 1:1

DESCRIPTION:  
FQSFP CAGE ASSEM  
DWG. NO.  
QSFP-C-X-X-X-XX-F

BY: JOE Z 06/20/2017 SHEET 4 OF 6

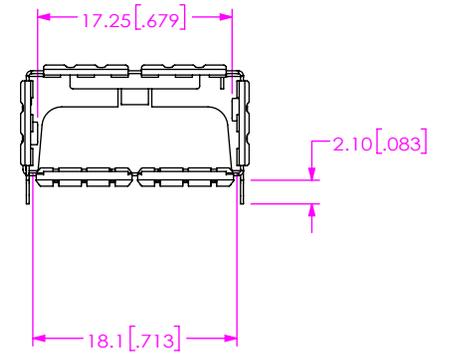
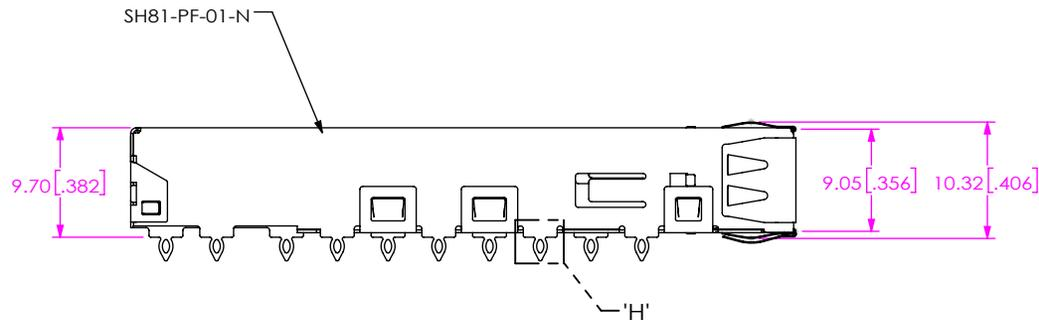
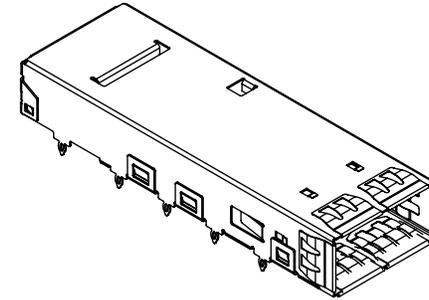
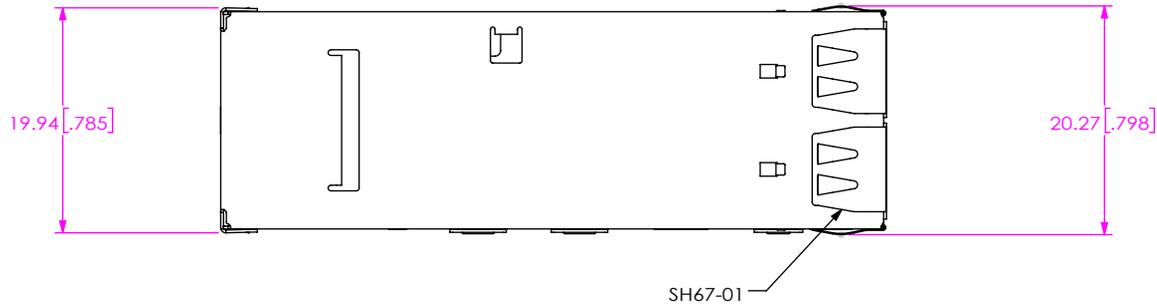
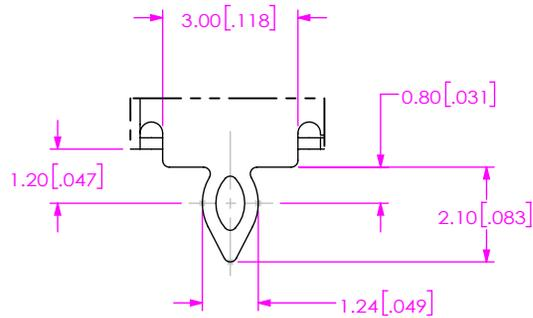

FIG 7  
QSFP-C-1-1-S-N-F SHOWN  
(SAME AS FIG 1, EXCEPT AS SHOWN)



DETAIL 'H'  
SCALE 6 : 1

PROPRIETARY NOTE

THIS DOCUMENT CONTAINS CONFIDENTIAL AND PROPRIETARY INFORMATION AND ALL DESIGN, MANUFACTURING, REPRODUCTION, USE, PATENT RIGHTS AND SALES RIGHTS ARE EXPRESSLY RESERVED BY SAMTEC, INC. THIS DOCUMENT SHALL NOT BE DISCLOSED, IN WHOLE OR PART, TO ANY UNAUTHORIZED PERSON OR ENTITY NOR REPRODUCED, TRANSFERRED OR INCORPORATED IN ANY OTHER PROJECT IN ANY MANNER WITHOUT THE EXPRESS WRITTEN CONSENT OF SAMTEC, INC.



520 PARK EAST BLVD, NEW ALBANY, IN 47150  
PHONE: 812-944-6733 FAX: 812-948-5047  
e-Mail: info@SAMTEC.com code 55322

SHEET SCALE: 1:1

DESCRIPTION:  
FQSFP CAGE ASSEM

DWG. NO.  
QSFP-C-X-X-X-XX-F

BY: JOE Z 06/20/2017 SHEET 5 OF 6

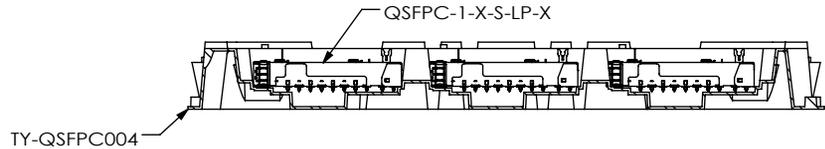
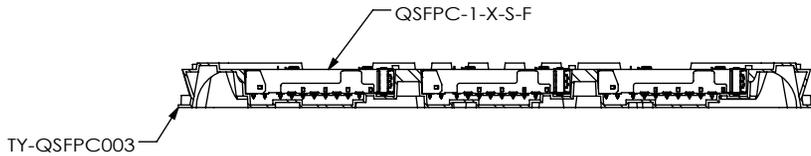
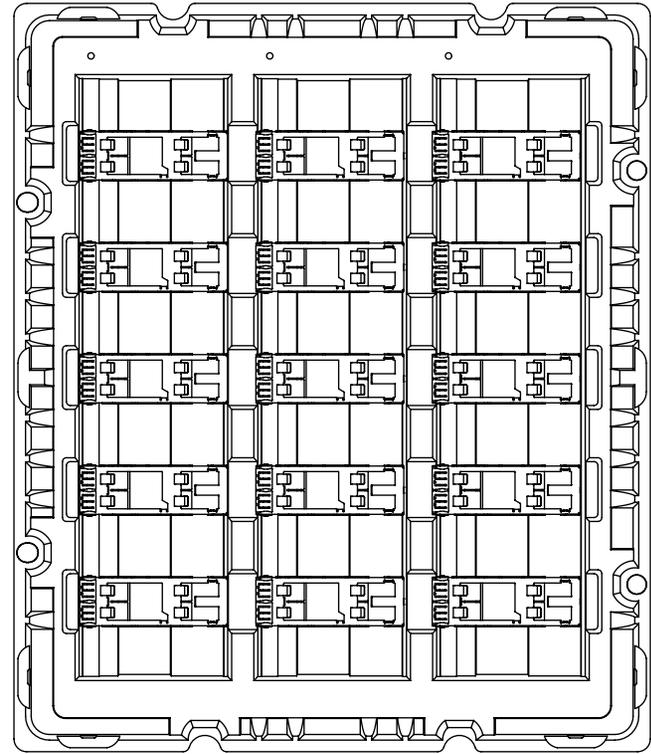
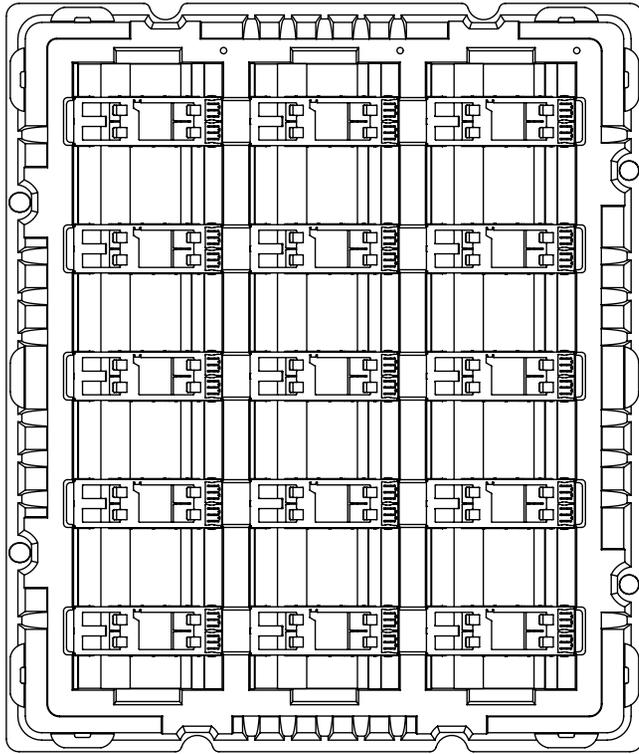

FIG 8  
PACKAGING VIEW

TABLE 3

PART NUMBER	TRAY
QSFP-1-1-S-F	TY-QSFPC003
QSFP-1-1-S	TY-QSFPC003
QSFP-1-2-S-F	TY-QSFPC003
QSFP-1-4-S-F	TY-QSFPC003
QSFP-1-1-S-LP-F	TY-QSFPC004

**PROPRIETARY NOTE**  
 THIS DOCUMENT CONTAINS CONFIDENTIAL AND PROPRIETARY INFORMATION AND ALL DESIGN, MANUFACTURING, REPRODUCTION, USE, PATENT RIGHTS AND SALES RIGHTS ARE EXPRESSLY RESERVED BY SAMTEC, INC. THIS DOCUMENT SHALL NOT BE DISCLOSED, IN WHOLE OR PART, TO ANY UNAUTHORIZED PERSON OR ENTITY NOR REPRODUCED, TRANSFERRED OR INCORPORATED IN ANY OTHER PROJECT IN ANY MANNER WITHOUT THE EXPRESS WRITTEN CONSENT OF SAMTEC, INC.

SHEET SCALE: 1:1



520 PARK EAST BLVD, NEW ALBANY, IN 47150  
 PHONE: 812-944-6733 FAX: 812-948-5047  
 e-Mail: info@SAMTEC.com code 55322

DESCRIPTION: FQSFP CAGE ASSEM

DWG. NO. QSFP-X-X-X-XX-F

BY: JOE Z 06/20/2017 SHEET 6 OF 6