

Introduction

Parallel Action Hand Tool CAT-HT-203-2830-12 was designed to crimp CC03M or CC03R (SFSS, SFSD, SFSSST, and SFSDT Part Series) contacts on 28 or 30 AWG Wire.

This tool should only be used for the terminals and wire gauges specified on this document. The tool is not adjustable. Variation in production batches of tools, connectors, wire stranding and insulation types may affect crimp parameters. This tool is intended for conductor sizes listed on this document. The tool may not give a good insulation crimp support for all wire insulation sizes of the same wire gauge.

Crimping Procedure

1. This tool can accept pins directly from a reel; however, if strips are preferred, Samtec recommends using ~6" length strips.
2. Squeeze the handles until the tool ratchet releases, allowing the handles to fully open (Figure 1).
3. Slide the terminal carrier strip under the contact holder plate and align the carrier strip feed holes with the locating ball detent features. This tool is designed for a double carrier strip terminal. The top carrier strip cut-off tool separates the terminal from the strip one-strip-feed distance prior to the crimp station (Figure 2).
4. Cycle the handle one or two times to ensure the top carrier strip is separated from the terminal. The terminal should now be properly positioned and ready to crimp (Figure 2)
5. Partially close the hand tool until you engage the first click of the ratchet.

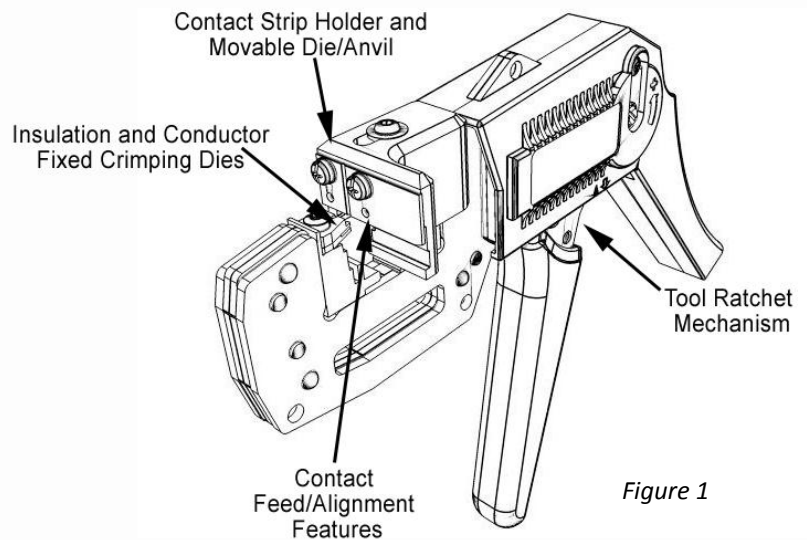

Figure 1

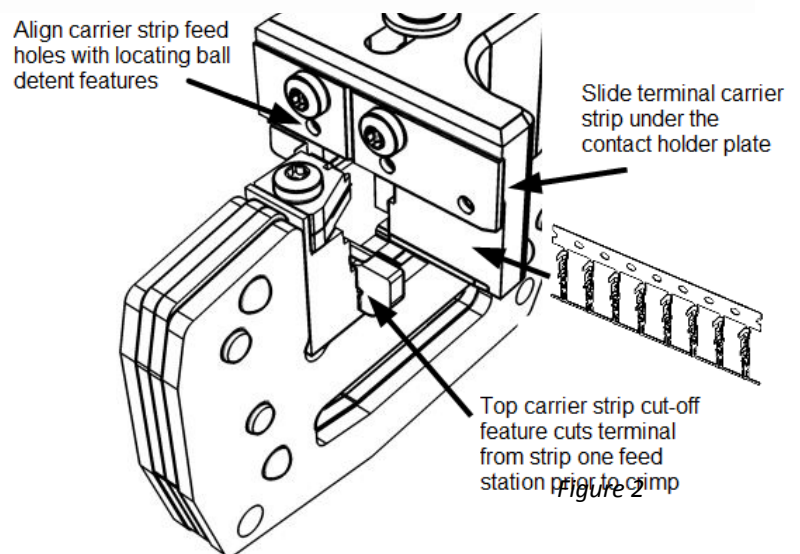

Figure 2

6. Insert a pre-stripped wire over the terminal crimp barrels; align the wire in the groove on the locator plate.
7. Close the handles together until the ratchet mechanism has completed the cycle and the handles release to the fully opened position.
8. Remove the crimped contact from the tool.
9. Manually feed the strip to locate the next terminal for crimping.

CAUTION: Should a terminal become stuck or jammed in a partially closed position, DO NOT use force to open or close the handles. The tool will easily open by pushing the ratchet release lever up (Figure 3).

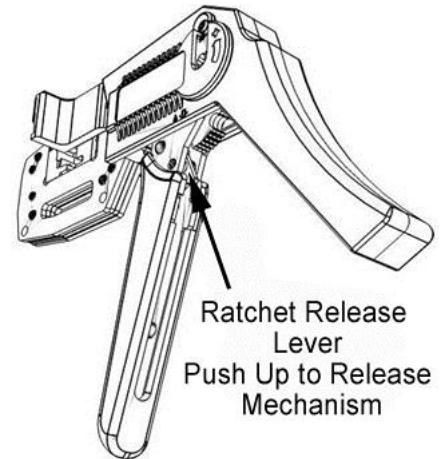

Figure 3

Tool Maintenance

It is recommended that each operator of the tool be made aware of, and be responsible for, following these maintenance steps:

- The tool was engineered for durability. However, for maximum service life and trouble free crimping, establish a good process of scheduled maintenance and lubrication.
- Remove dust, moisture and other contaminants with a clean brush or soft, lint-free cloth ONLY.
- Make certain all pins, pivot points and bearing surfaces are protected with a thin coat of high quality machine oil. Do NOT oil excessively (Figure 4).
- Wipe excess oil from the hand tool, particularly from the crimping area.
- It is recommended to use light oil on all pivot points every 5000 crimps, or every 3 months.
- When tool is not in use, keep the handles closed to prevent objects from becoming lodged in the crimping area.
- Store the tool in a clean dry place.

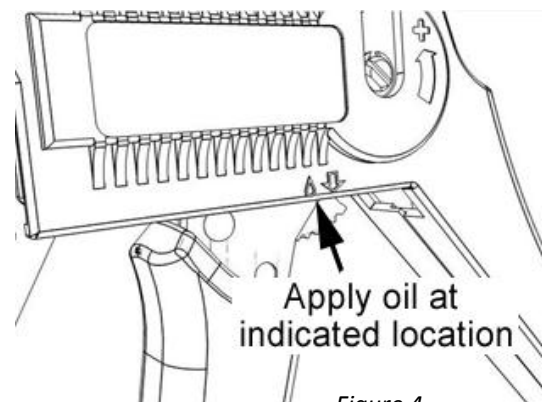

Figure 4

Adjusting the Handle Pre-Load

The tool is calibrated at the factory to the optimum pre-load required to achieve a proper crimp. It may become necessary, over the life of the tool, to adjust the handle pre-load force.

Follow the steps below to adjust the crimping force of the hand tool to obtain proper crimp parameters (Figure 5):

- Remove 2 mm locking screw from the adjustment wheel using TORX head wrench.
- Using a small screwdriver, turn the adjustment wheel to the next marked position.
- The tool uses an eccentric axle linkage mechanism. To increase the handle pre-load, move the wheel clockwise to the next highest odd number, or counterclockwise to the next highest even number.

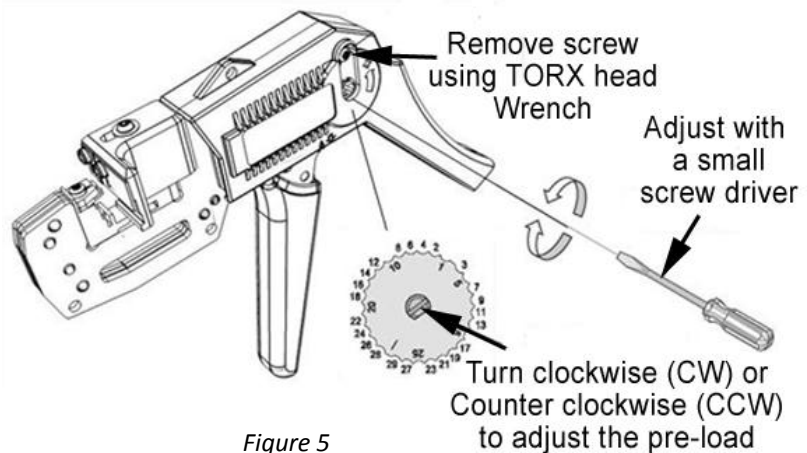

- Turn the wheel until the desired number is located over the 2 mm tapped hole.
- Replace the 2 mm locking screw, aligning the nearest notch in the setting wheel.
- Check the crimp against the specifications, and conduct a pull test after the tool handle pre-load force is adjusted. Repeat the steps until the desired crimp performance is obtained.