



# Application Note

## **RiseUp® RU8-DP-DV Series 19mm Stack Height Final Inch® Designs in Serial ATA Generation 1 Applications**

Revision Date: March 18, 2005

**Copyrights and Trademarks**  
Copyright © 2005 Samtec, Inc.

Developed in conjunction with  
Teraspeed Consulting Group LLC

**Series:** RU8-DP-DV, 19mm Stack Height  
**Standard:** Serial ATA (Generation 1)

## COPYRIGHTS, TRADEMARKS, and PATENTS

RiseUp® and Final Inch® are trademarks of Samtec, Inc. Other product names used herein are trademarks of their respective owners. All information and material in this publication are property of Samtec, Inc. All related rights are reserved. Samtec, Inc. does not authorize customers to make copies of the content for any use.

### ***Terms of Use***

Use of this publication is limited to viewing the pages for evaluation or purchase. No permission is granted to the user to copy, print, distribute, transmit, display in public, or modify the contents of this document in any way.

### ***Disclaimer***

The information in this publication may change without notice. All materials published here are “As Is” and without implied or expressed warranties. Samtec, Inc. does not warrant this publication will be without error, or that defects will be corrected. Samtec, Inc. makes every effort to present our customers an excellent and useful publication, but we do not warrant or represent the use of the materials here in terms of their accuracy, reliability or otherwise. Therefore, you agree that all access and use of this publication's content is at your own risk.

NEITHER SAMTEC, INC. NOR ANY PARTY INVOLVED IN CREATING, PRODUCING, OR DELIVERING THIS PUBLICATION SHALL BE LIABLE FOR ANY DIRECT, INCIDENTAL, CONSEQUENTIAL, INDIRECT, OR PUNITIVE DAMAGES ARISING OUT OF YOUR ACCESS, USE OR INABILITY TO ACCESS OR USE THIS PUBLICATION, OR ANY ERRORS OR OMISSIONS IN ITS CONTENT.

**Series:** RU8-DP-DV, 19mm Stack Height  
**Standard:** Serial ATA (Generation 1)

## **Abstract**

The Serialized AT Attachment Interface (Serial ATA or SATA) is primarily intended as a low voltage, point-to-point, serialized replacement to legacy ATA, the parallel interface used for years to connect hard drives to CPU mother boards. Cable lengths are comparable to parallel ATA (<1 m at 1.5 Gbits/sec bit rate). As with any modern high speed PCB design, the performance of an actual Serial ATA interconnect is highly dependent on the implementation. This paper describes a measurement method applied to proven Samtec Final Inch® designs and this industry standard to help engineers deploy systems of two PCB cards mated through Samtec's family of high speed electrical connectors. To demonstrate the feasibility of using Samtec RiseUp® RU8-DP Series differential pair connectors with standard FR4 epoxy PCBs, informative interconnect loss and jitter values will be measured through SPICE simulation and presented in spreadsheet format. Also, trace lengths on each side of the connector will be gradually increased to show the limits of compliance.

In order to ensure interoperability between Serial ATA transmitter and receiver devices, we will show that our Final Inch® test fixture meets all success criteria documented in **Table 4 – Signal integrity requirements and test procedures** in the Serial ATA specification, Revision 1.0a, 7-January-2003. These requirements are intended for testing of cable designs, so to stay true to the SATA specifications intent, the requirements will be met for the entire signal path from the near-end SMA connectors to the far-end SMA connectors (see fixture illustration, Figure 1). Trace lengths will be varied to show the limits of compliance.

**Series:** RU8-DP-DV, 19mm Stack Height  
**Standard:** Serial ATA (Generation 1)

## Introduction

Samtec has developed a full line of connector products that are designed to support serial speeds up to and greater than 1.5 Gbps, the “Baud rate” of each Generation 1 Serial ATA data lane. Working with Teraspeed Consulting, they have developed a complete breakout and routing solution for each member of Samtec’s line of high speed connectors, called Final Inch®. To demonstrate the feasibility of using Samtec RiseUp® RU8-DP Series connectors in Serial ATA applications with standard FR4 epoxy PCBs, informative interconnect loss and jitter values will be measured through SPICE simulation and presented in a user-friendly spreadsheet format. Trace lengths will be varied to show the limits of compliance.

Analysis will consist of stimulating a typical trace-connector-trace circuit path with a worst case signal and then observing the corresponding eye closure related to reflections due to impedance discontinuities, loss, and stubs. Next, utility software will be used to extract, analyze, and format SPICE-measured voltage amplitudes and differential signal crossing times. Mask violations (see Figure 12) will be recorded in pass/fail format.

## Definitions

**Crosstalk** - Disturbance caused by the electric or magnetic fields of one telecommunication signal affecting a signal in an adjacent circuit. The phenomenon that causes crosstalk is called electromagnetic interference (EMI). It can occur in microcircuits within computers and audio equipment as well as within network circuits. The term is also applied to optical signals that interfere with each other.

**DJ** - Deterministic Jitter (peak to peak). All jitter sources that do not have tails on their probability distribution function (i.e. values outside the bounds have probability zero). Four kinds of deterministic jitter are identified: duty cycle distortion, data dependent (ISI), sinusoidal, and uncorrelated (to the data) bounded. DJ is characterized by its bounded, peak-to-peak value.

**Interconnect Budget** – The amount of loss and jitter that is allowed in the interconnect and still meet the target specification.

**Loss** – The differential voltage swing attenuation from transmitter to receiver on the trace. The trace is subject to resistive, dielectric, and skin effect loss. Loss increases as trace length and and/or signal frequency increases. Vias and connectors also exhibit losses which must be included in the interconnect budget.

**Series:** RU8-DP-DV, 19mm Stack Height  
**Standard:** Serial ATA (Generation 1)

**Insertion Loss** - The loss resulting from the insertion of a device in a transmission line, expressed as the reciprocal of the ratio of the signal power delivered to that part of the line following the device to the signal power delivered to that same part before insertion. Insertion loss is usually expressed in dB.

**Jitter** – The variation in the time between differential crossings from the ideal crossing time. Jitter includes both data dependent and random contributions on the interconnect.

**PRBS** – Pseudo Random Bit Sequence.

**RJ** - Random Jitter (peak to peak). Assumed to be Gaussian and equal to 14 times the  $1\sigma$  rms value given the  $10^{-12}$  BER requirement.

**TJ** – Total jitter, which is the convolution of the probability density functions for all the jitter sources, Random jitter (RJ) and Deterministic jitter (DJ). The UI allocation is given as the allowable TJ.

**UI** – Unit Interval. The time interval required for transmission of one data symbol. For a binary lane operating at 1.5 Gbps, the UI is 666.7 ps.

**V<sub>DIFF</sub>** – Differential voltage, defined as the difference of the positive conductor voltage and the negative conductor voltage ( $V_{D+} - V_{D-}$ ).

**V<sub>DIFFp-p</sub>** – Differential peak-to-peak voltage, defined by the following equations:

$$V_{DIFFp-p} = (2 * \max | V_{D+} - V_{D-} |) \text{ (Applies to a symmetric differential swing)}$$

$$V_{DIFFp-p} = (\max | V_{D+} - V_{D-} | \{ V_{D+} > V_{D-} \} + \max | V_{D+} - V_{D-} | \{ V_{D+} < V_{D-} \}) \\ \text{(Applies to a asymmetric differential swing)}$$

**Series:** RU8-DP-DV, 19mm Stack Height  
**Standard:** Serial ATA (Generation 1)

## The Serial ATA Specification

Serial ATA links are based on recent advances in point-to-point interconnect technology. A Serial ATA lane is comprised of a dual-simplex communications channel between two components physically consisting of two low-voltage, differential signal pairs. One lane is used to convey self-clocking data and control, each at a nominal rate of ~1.5 Gbps.

The Serial ATA specification, errata, and design guidelines can be downloaded free of charge at the organization’s web site, <http://www.serialata.org/>. Detailed physical layer electrical specifications for the Serial ATA can be found starting in Section 6.6.2 for the specification. Relevant timing and voltage constraints from this section of the specification will be referred to in the section on validating the RiseUp® RU8-DP Series Final Inch® Test Fixture when used as a complete system.

## RiseUp® RU8-DP Series Final Inch® Test Fixture Validation When Used As a Substitute for the SATA Cable

Readers may be interested in how the RU8-DP Series test fixture fares when it is used in place of the Serial ATA cable. The Serial ATA specification makes this fairly easy to ascertain, as cable signal integrity requirements can be found in Table 4 of Section 6.3.6, Serial ATA cable. The following table summarizes the requirements to be met, and which ones apply to SPICE simulation and measurement.

Parameter	Requirement	Relevant to fixture Spice Model?
Mated connector impedance	100 ohm +/- 15% @ Trise=70ps (20%-80%)	Yes
Cable absolute impedance	100 ohm +/- 10% @ Trise=70ps (20%-80%)	Yes
Cable pair matching	+/- 5 ohm	No
Common mode impedance	25 to 40 ohms @ Trise=70ps (20-80)	Yes
Insertion loss	6 dB max @ 4.5 Ghz	Yes
Crosstalk: NEXT	-26 dB @ 4.5 Ghz	Yes
Rise time	85 ps maximum	Yes
Inter-symbol Interference	50 ps maximum	Yes
Intra-Pair Skew	10 ps max	No

**Table 1 - Serial ATA Signal Integrity Requirements**

**Series:** RU8-DP-DV, 19mm Stack Height  
**Standard:** Serial ATA (Generation 1)

### Setup and Measurement

#### The RiseUp® RU8-DP Series Test Circuit Model

The RiseUp® RU8-DP Series test circuit modeled is shown in Figure 1. It consists of the following:

- RU8 Series mated connector model which consists of two HSEC8-DV-DP Series connectors and one HSC8-DP Series Riser card
- BOR models for both connectors
- Microstrip trace modes, variable length

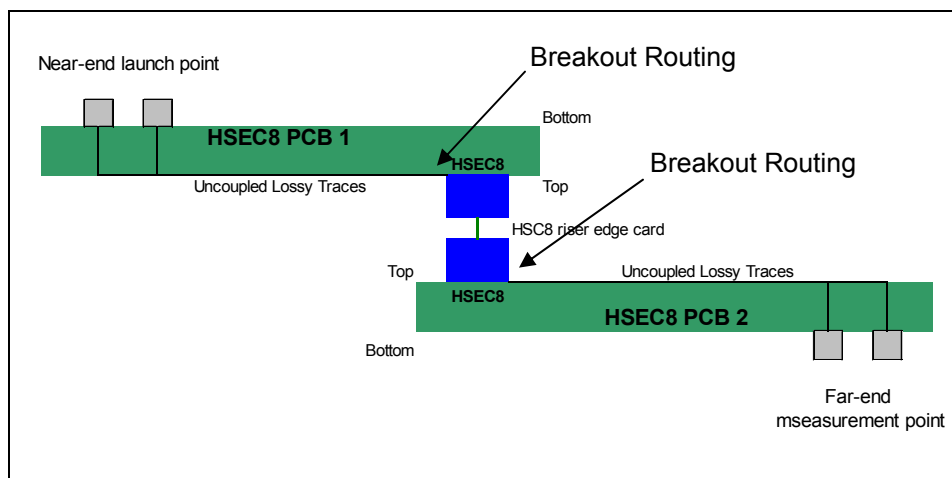

Figure 1 – RiseUp® RU8-DP Series Final Inch® Test Fixture

### Test Procedure

#### Insertion Loss

We deliberately did the insertion loss simulations first to determine the maximum total test fixture trace length we could reliably use for the rest of the procedure. For this measurement, we connected the differential pair input to a 1 Volt a.c. stimulus linearly swept from 10 MHz to 4.5 GHz. The far-end of the test fixture was terminated differentially at the measurement point, value=100 Ohms. The extra differential pairs on either side of the circuit under test were terminated at both end points, 50 Ohms to Ground. Results for various total trace lengths are shown in Figure 2. Both near-end and far-end trace lengths were kept equal for each measurement.

**Series:** RU8-DP-DV, 19mm Stack Height  
**Standard:** Serial ATA (Generation 1)

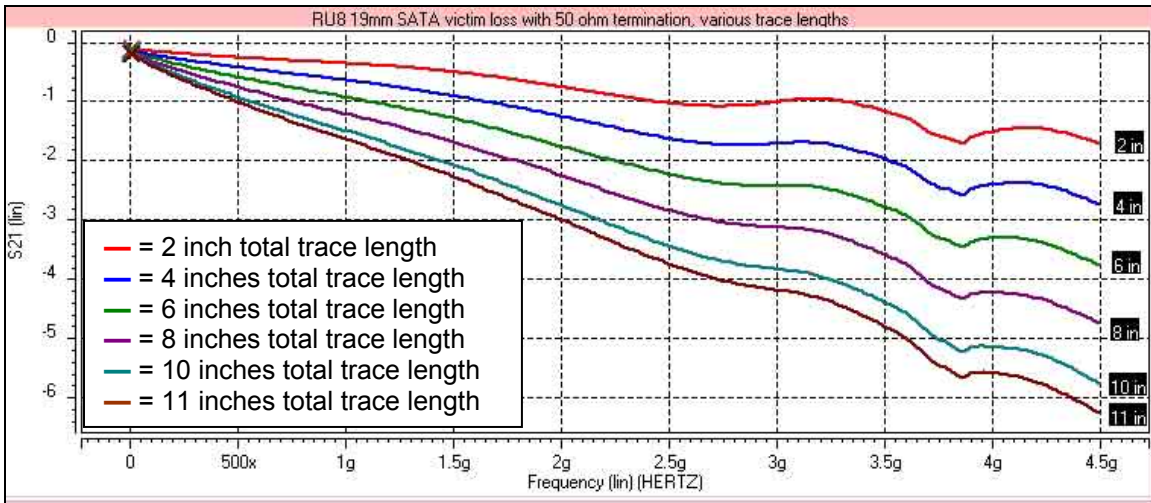

**Figure 2 – Serial ATA circuit insertion loss**

The Serial ATA test circuit meets the insertion loss specification if total trace lengths are kept at or below 10 inches. We will use 10 inches total trace length in the rest of the test procedure.

Readers may be curious to know how much of this loss is from the connector/BOR and how much can be contributed to the traces. Figure 3 shows the insertion loss with our 10 inches of trace, with (blue) and without (red) the connector and breakout regions present. At 4.5 GHz, the connector with breakout and extender card add only .725 dB of insertion loss.

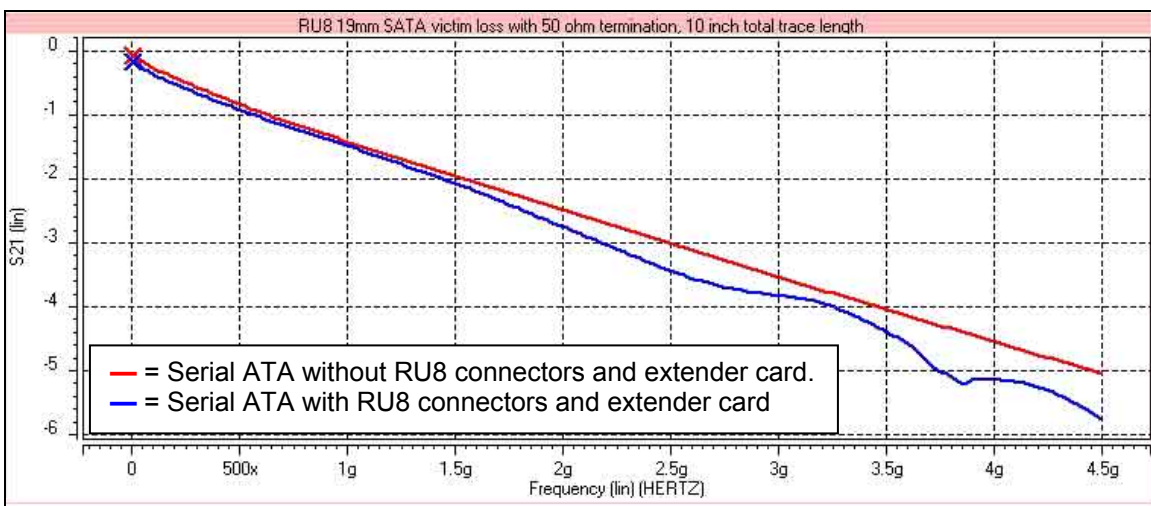

**Figure 2 - Insertion loss comparison of 10 inch trace with and without RU8 connector, breakouts, and extender card.**

**Series:** RU8-DP-DV, 19mm Stack Height  
**Standard:** Serial ATA (Generation 1)

## Crosstalk: NEXT

To test near-end crosstalk, all of the test fixtures' differential pairs were configured in an aggressor-victim-passive setup.

- Pair 1 - Aggressor Signal. Pair Input Stimulus - 1 Volt a.c. linearly swept from 10 MHz to 4.5 GHz
- Pair 2 - Victim Signal Pair terminated at measurement point, 100 Ohms
- Pair 3 - Passive Signal Pair terminated at both end points, 50 Ohms to Ground

Figure 4 shows the location of the victim pair on the connector.

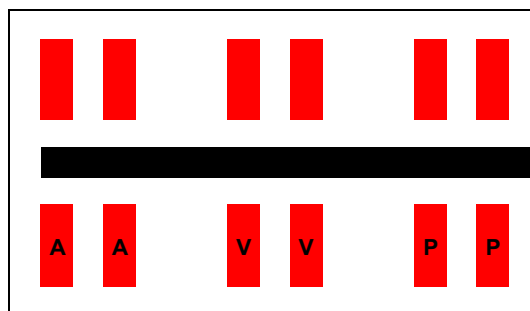

**Figure 3 – RiseUp® RU8-DP Series differential connector pin pattern**

V = Victim pair, A = Aggressor pair

Results for NEXT with 10 inches total trace length are shown in Figure 5.

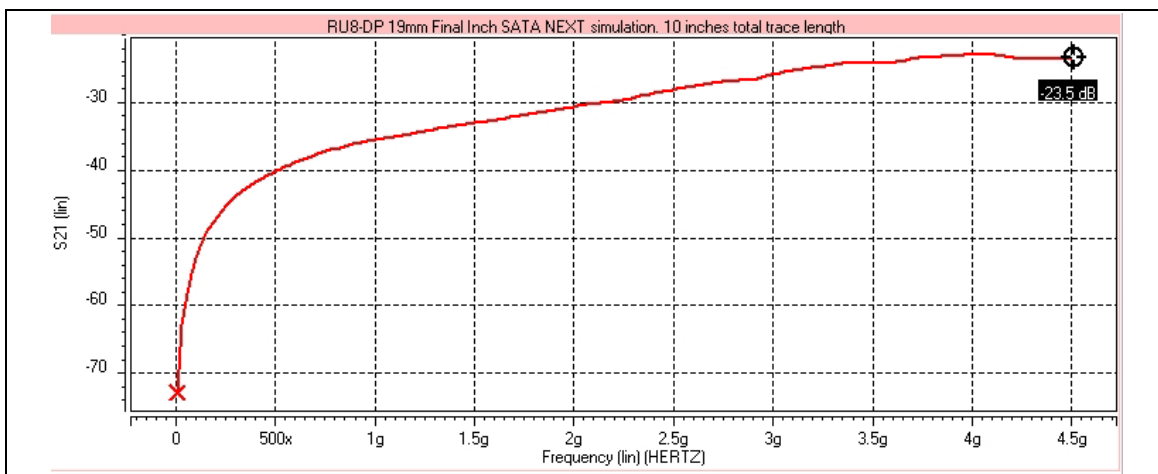

**Figure 4 – RiseUp® RU8-DP Series 19 mm circuit NEXT simulation results, 10 inches total trace length**

The RiseUp® RU8-DP Series 19 mm Serial ATA test circuit does not meet the near-end crosstalk requirement of -26 dB at 4.5 GHz.

**Series:** RU8-DP-DV, 19mm Stack Height  
**Standard:** Serial ATA (Generation 1)

### Mated Connector-Card-Connector Impedance

The following figure shows the TDR response for the RiseUp® RU8-DP Series 19 mm extender (connector-card-connector) when used in the Final Inch® circuit. Note that 50 Ohm T-element traces were used on each side of the connectors with delays set to 250 ps.

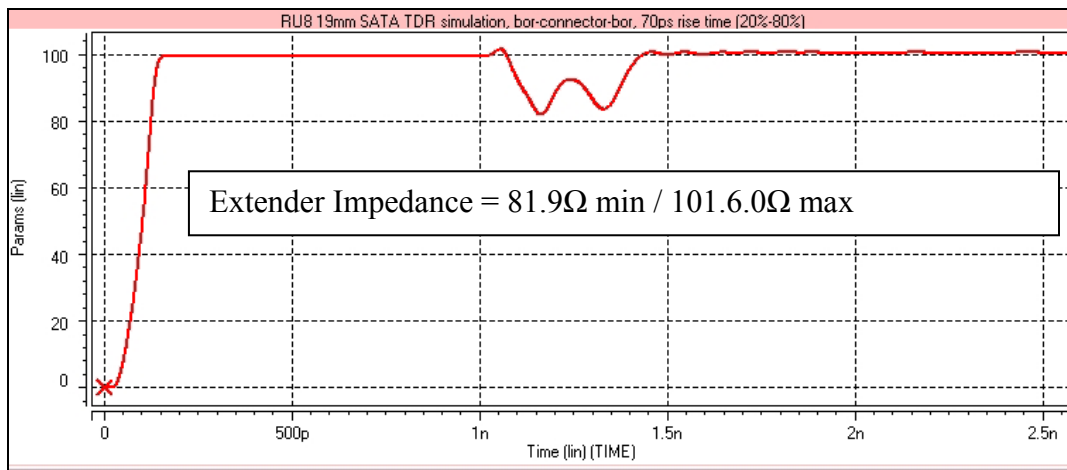
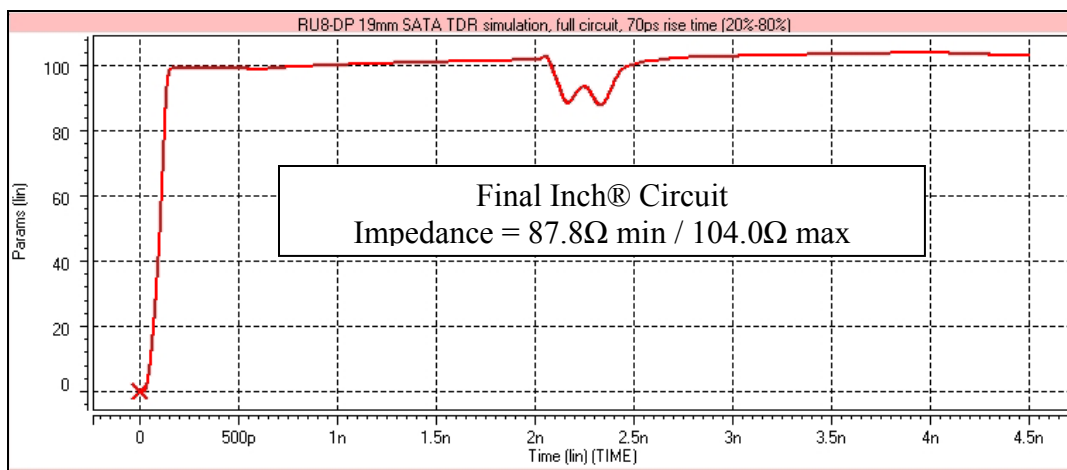

**Figure 5 – RiseUp® RU8-DP Series 19 mm Connector-Extender-Connector TDR results**

The extender does not meet the impedance criteria of 100 ohms +/-15%.

### Final Inch® Circuit Absolute Impedance

The results of the full circuit TDR is shown in Figure 7 below.



**Figure 6 – RiseUp® RU8-DP Series 19 mm Final Inch® circuit TDR results**

The Final Inch® circuit does not meet the impedance criteria of 100 ohms +/-10% set forth in the Serial ATA Specification for cable compliance.

**Series:** RU8-DP-DV, 19mm Stack Height  
**Standard:** Serial ATA (Generation 1)

## Common Mode Impedance

To determine the common mode impedance, we set both TDR pulsers to produce positive going pulses, then measured the even mode impedance of each signal in the differential pair. The common mode impedance is determined by dividing the results by 2.

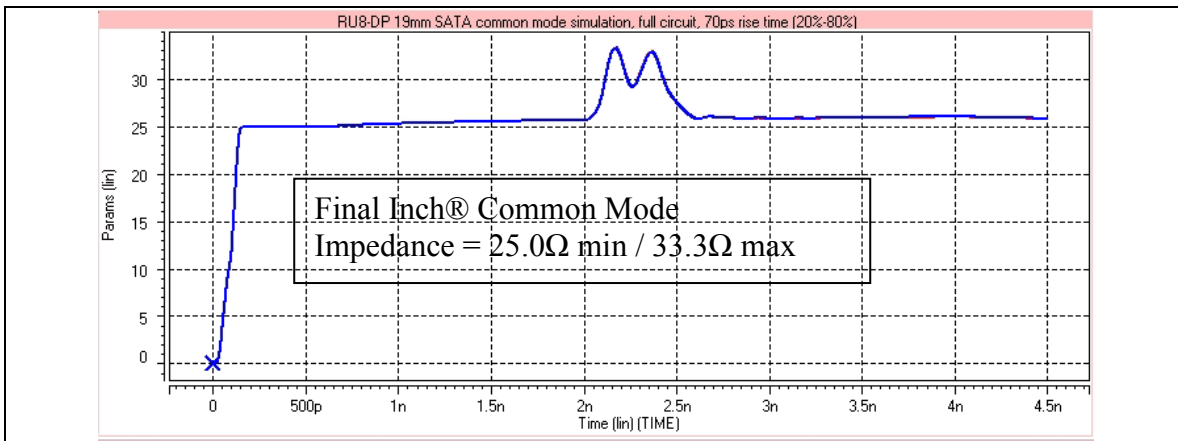
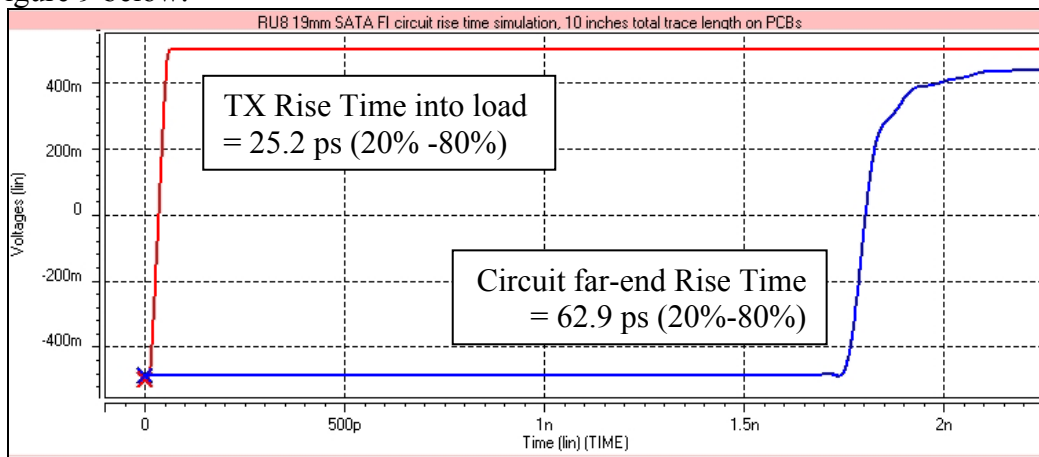

**Figure 7 – RiseUp® RU8-DP Series 19 mm Final Inch® circuit common mode impedance**

The Final Inch® circuit meets the specified common mode range of 25 to 40 ohms.

## Rise Time

The Serial ATA specification indicates that the far-end rise time requirement is 85 ps maximum. With a synthetic driver set to the minimum allowed 25 ps rising edge rate, the results indicate the Final Inch® circuit with 10 inches total trace length is within the maximum allowed 85 ps far-end edge rate. The transmitter and receiver edges are shown in Figure 9 below.

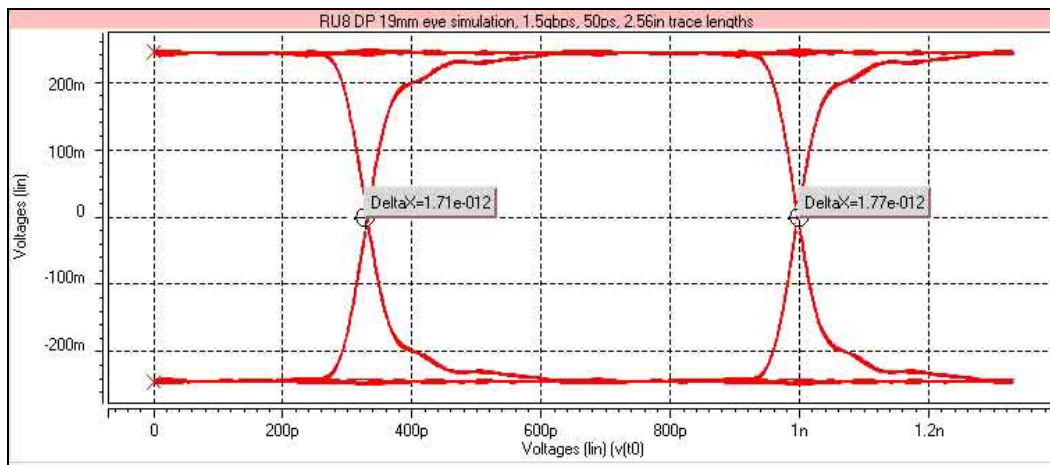

**Figure 8 – RiseUp® RU8-DP Series 19 mm Final Inch® circuit rise time results with 10 inches total trace length; Red = TX driving compliance load; Blue = Final Inch® circuit probed at the far-end termination**

**Series:** RU8-DP-DV, 19mm Stack Height  
**Standard:** Serial ATA (Generation 1)

## Inter-symbol Interference

To test the inter-symbol interference requirement of  $\pm 50$  ps maximum, a PRBS  $2^7-1$  pattern was used for the victim pair stimulus and a repeating 1010... pattern used for the aggressor pairs on each side of the victim pair. Utility software was then used to extract, analyze, and format SPICE-measured differential signal crossing times. The resulting eye waveform is shown in Figure 10 along with the measured jitter value.



**Figure 9 – RiseUp® RU8-DP Series 19mm Final Inch® circuit eye**

The Serial ATA test circuit easily meets the inter-symbol interference jitter requirement of not more than  $\pm 50$  ps

## Conclusions

The Samtec RiseUp® RU8-DP Series 19 mm stack height connector set in a Final Inch® TX board/RX board configuration does not meet the Serial ATA compliance specification for system cables. One should keep in mind that the Serial ATA specification defines the cable to be 26 or 30 AWG. The trace geometry used on the Final Inch® PCBs is the equivalent to approximately 42AWG (based on 4 mil wide traces; 1 oz Cu thickness). The equivalent trace width (1 oz thick) for 26 AWG is about 153 mils wide; for 30 AWG it is about 60 mils wide; for 38 AWG, it is about 9.5 mils wide.

Because loss is the dominant contributor to system degradation, designers should be aware that using smaller trace widths, laminates with higher loss tangent, and sub optimal routing solutions with higher pair-to-pair coupling and additional via stubs will decrease overall performance and the maximum allowable trace length. It is advisable, when designing systems that approach the maximum jitter limits, to perform detailed modeling, simulation, and measurement of the target design including the effects of material properties, traces, vias, and additional components.

**Series:** RU8-DP-DV, 19mm Stack Height  
**Standard:** Serial ATA (Generation 1)

## **RiseUp® RU8-DP Series Final Inch® Test Fixture Validation When Used As a Complete System**

### ***Setup and Measurement***

#### **Input Stimulus Setup**

A PRBS  $2^7-1$  pattern was used for victim stimulus and a repeating 1010... pattern used for the aggressor differential pairs on each side of the victim differential pair. Xilinx supplies a stimulus generator tool kit within their VirtexII Pro™ design kit giving customers complete control over the amount of jitter in the transmitter's data output. Using their stimulus system with their RocketIO® multi-gigabit serial transceiver model, enough total jitter was added to the driver output to just meet worst case Serial ATA transmit jitter specifications. The slow-slow corner silicon model was used to come as close as possible to the minimum differential  $V_{DIFF}$  output specification.

#### **The Test Circuit Model**

The test circuit modeled is shown in Figure 11. It consists of the following:

- One set of three of Xilinx Virtex-II Pro™ Serial transceiver models configured as Serial ATA drivers
- Xilinx FPGA flip-chip package model
- 1 Samtec RiseUp® RU8-DP Series Final Inch® design model comprised of
  - two HSEC8 Series differential Test Boards with HSEC8-104-01-X-DV connectors surrounded by the Samtec BOR models, lossy trace models, and SMA connector models on each test board
  - one HSC8-040-02-19-DP differential pair riser card
- One set of six AC coupling capacitors, value = 10 nF.
- 100 Ohm termination resistors.

Series: RU8-DP-DV, 19mm Stack Height  
 Standard: Serial ATA (Generation 1)

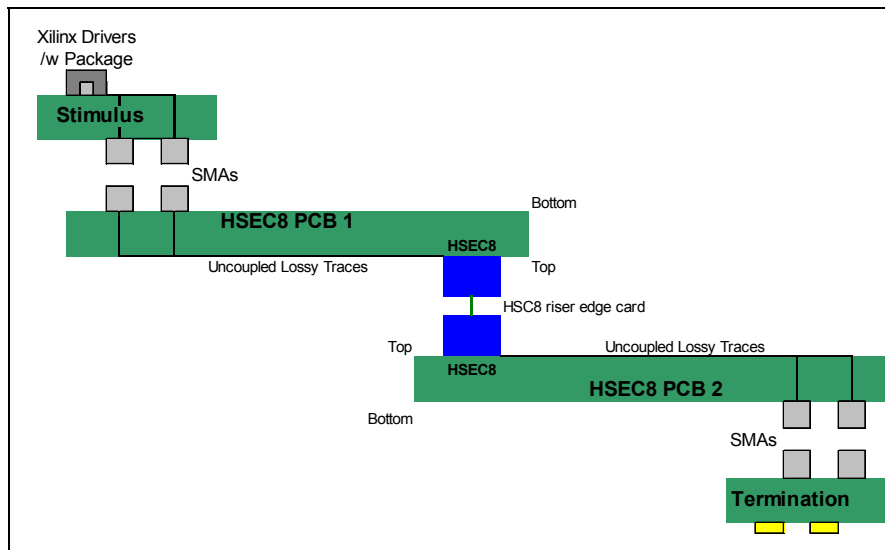

Figure 10 - Serial ATA System Test Circuit

## Procedure

### Interconnect Budget

The interconnect budget can be best illustrated by the mask shown in Figure 12. In order to pass the Serial ATA constraints for loss and jitter, the simulated eye waveform must not touch any location within the grey areas shown. Calculated interconnect budget values are shown in Table 3.

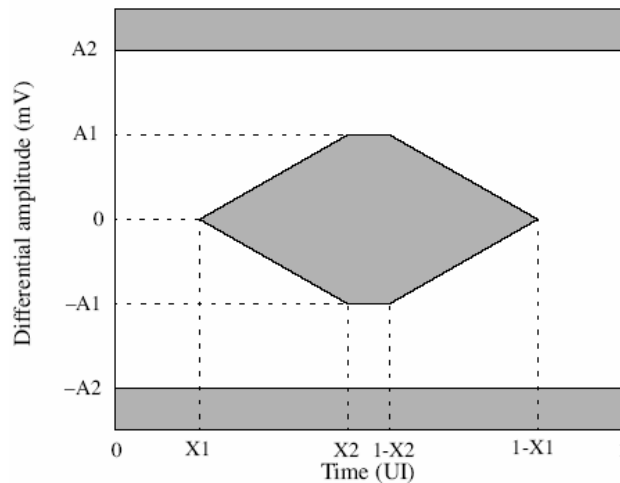

Figure 11 -Example mask template

**Series:** RU8-DP-DV, 19mm Stack Height  
**Standard:** Serial ATA (Generation 1)

Symbol	Near-end value	Far-end value	Units
X1	220.0	286.7	psec maximum
X2 <sup>1</sup>	0	0	psec
A1	200	162.5	mV minimum
A2	300	300	mV maximum

**Table 2 - Serial ATA mask template intervals at 1.5 Gbps**

<sup>1</sup>X2 is not specified in the Serial ATA specification. The time between X2 and 1-X2 is assumed to be 0 psec.

	Maximum Loss, A1 to -A1 (See example mask template) (mV <sub>DIFFp-p</sub> )	Minimum Eye Width, X1 to 1-X1 (See example mask template) (UI <sub>p-p</sub> )
Driver at Package Pin	400	0.65
Receiver at Package Pin	325	0.45
Interconnect budget:	1.8 dB loss <sup>1</sup>	0.2 UI <sub>p-p</sub> (133.3ps when UI=666.7 ps)

**Table 3 - Serial ATA interconnect budget max loss and min eye width calculated values**

<sup>1</sup>The worst case operational loss budget at Nyquist frequency is calculated by taking the minimum input voltage to the receiver ( $V_{RX-DIFF} = 325$  mV) divided by the minimum driver output voltage ( $V_{TX-DIFF} = 400$  mV)  $325/400 = .8125$ , which after conversion results in a maximum loss budget of 1.8 dB.

## Transmitter Compliance Measurements

### Setup for Tj for UI Measurements

As mentioned in the previous section, the driver stimulus' jitter was adjusted until the transmitter exhibited the maximum total jitter allowed by the Serial ATA specification at the driver package pins under the compliance load shown in Figure 13 below. The Serial ATA specification does not specify the range of capacitor values allowed for the AC coupling capacitors. We set C to 100nF for all simulations because it is a popular value in the industry. Table 4 shows the resulting output measurements.

Series: RU8-DP-DV, 19mm Stack Height  
 Standard: Serial ATA (Generation 1)

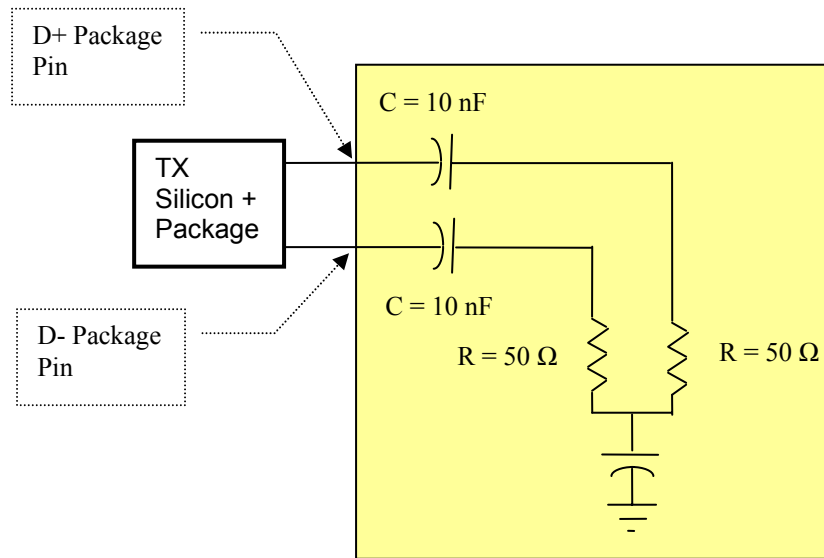

Figure 12 - Serial ATA Compliance Test/Measurement load

	$V_{p-p}$	Total Jitter
Specification	$\geq 400$ mV	$\leq 220$ ps
Measured	400.0 mV	220 ps

Table 4 - Serial ATA TX Silicon + Package Measurements at Package Pin

The eye pattern generated in the Serial ATA driver compliance test simulation can be found in [Appendix A](#) of this paper, picture #1.

Series: RU8-DP-DV, 19mm Stack Height  
 Standard: Serial ATA (Generation 1)

### Full Circuit Compliance Measurements

#### Differential Voltage and Eye Width Measurements at Receiver End

The measurement results of the Serial ATA circuit simulations are shown in Table 5.

RU8 Series, 19 mm Stack Height	Max Jitter at UI = 666.7 psec	Min RX Eye Width, X1 to 1-X1 (See example mask template)	Min Rx Differential Voltage, A1 to -A1 <sup>1</sup> (See example mask template)	Pass/Fail
Specification	≤ 286.6 psec	≥380 psec	≥325mV <sub>p-p</sub>	-
4" total trace <sup>2</sup>	234.7	641.2	382.0	Pass
8" total trace	233.6	639.5	374.2	Pass
12" total trace	233.3	637.7	368.8	Pass
16" total trace	229.9	635.8	357.6	Pass
20" total trace	229.2	633.5	346.0	Pass
21" total trace	237.7	620.3	305.6	Fail

Table 5 - Serial ATA Measurements at Receiver End, RiseUp® RU8 Series 19 mm stack height

<sup>1</sup>X2 to 1-X2, the mid bit sample time, is unspecified and assumed to be 0 ps.

<sup>2</sup>The total trace length specified is the sum of the two differential trace lengths in the RU8-DP test fixture model, as shown in Figure 11. These traces are always kept equal in length in each simulation.

The eye pattern generated in the Serial ATA circuit simulation with 20 inches total trace length can be found in [Appendix A](#) of this paper, picture #2. Superimposed on top of this eye waveform are the simulation results of the same circuit but without the connector and breakout.

### Conclusions

A single Samtec RiseUp® RU8-DP Series with a 19mm stack height in a differential pair board-to-board configuration can be used in Serial ATA systems with total trace lengths not to exceed 20 inches when used with Samtec’s Final Inch® routing, breakout, and trace width solutions. Because loss is the dominant contributor to system degradation, designers should be aware that using smaller trace widths, laminates with higher loss tangent, and sub optimal routing solutions with higher pair-to-pair coupling and additional via stubs will decrease overall performance and the maximum allowable trace length. It is advisable, when designing systems that approach the maximum jitter limits, to perform detailed modeling, simulation, and measurement of the target design including the effects of material properties, traces, vias, and additional components.

**Series:** RU8-DP-DV, 19mm Stack Height  
**Standard:** Serial ATA (Generation 1)

## Appendix A – Waveform images

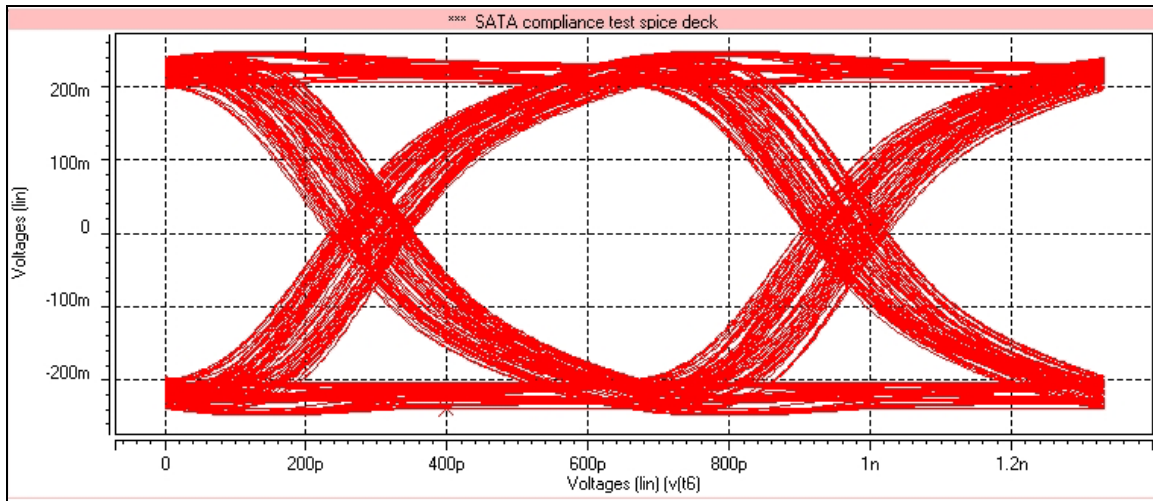

**Picture 1 – Worst case stimulus eye waveform, probed at Xilinx driver package pins and connected to compliance test/measurement load.**

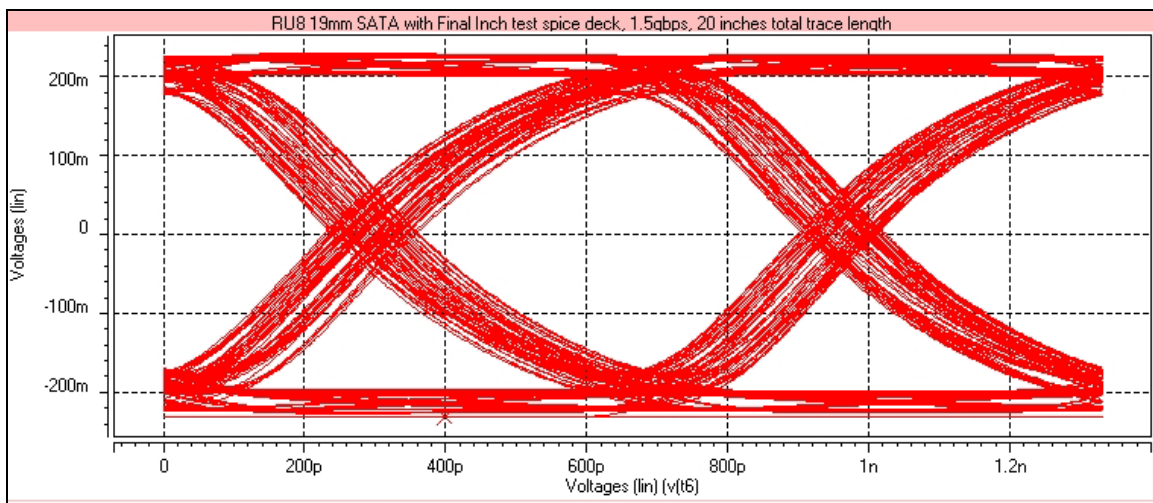

**Picture 2 – Serial ATA circuit eye waveform, probed at terminator pins, 20 inches total trace length**