

DO NOT SCALE FROM THIS PRINT

DESIGNED & DIMENSIONED IN MILLIMETERS [INCHES]

ADP7-04SP2-H4SJ2

IMPEDANCE  
-7: 75 OHM

PLATING SPECIFICATION  
-HN: HEAVY GOLD / NICKEL  
30µ" Au / 50µ" Ni MIN ON PIN  
100µ" Ni MIN ON OUTER CONTACT  
(SEE TABLE 1)

END 1  
-04SP: BNC STRAIGHT PLUG

END 2  
-H4SJ: HDBNC STRAIGHT JACK

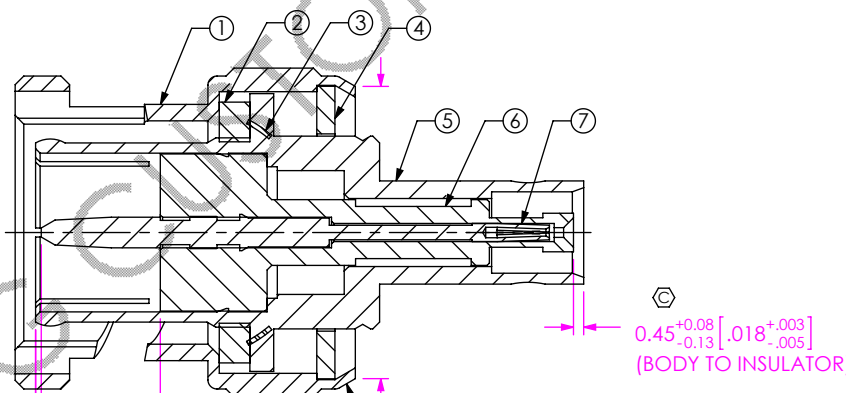
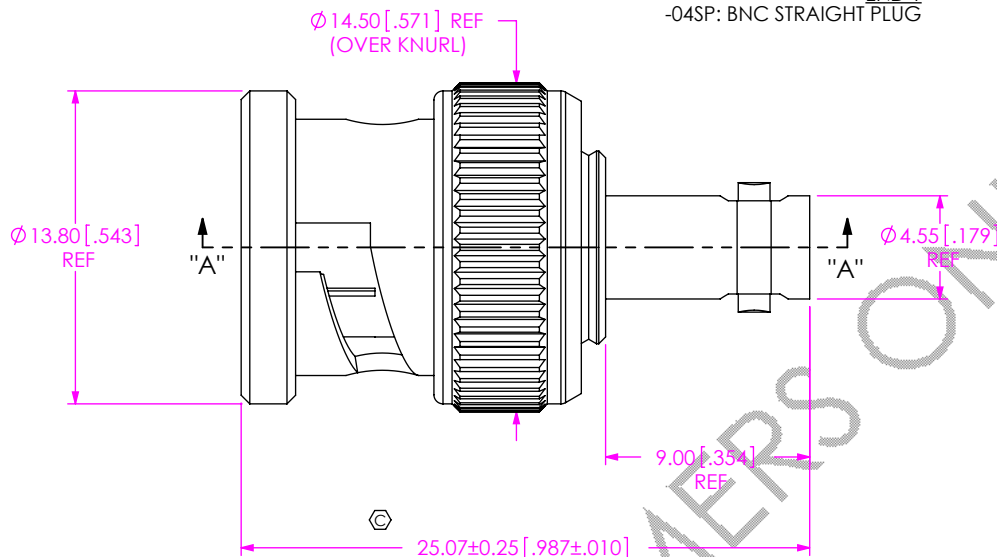

SECTION "A"-"A"

TABLE 1

ITEM	COMPONENT	-HN
1	COUPLING NUT	BNC-CNUT-001-N
2	GASKET	BNC-GKT-001
3	SPRING WASHER	BNC-SWAS-001-N
4	FLAT WASHER	BNC-FWAS-001-N
5	BODY	ADP7-04SP2-H4SJ2-BDY
6	INSULATOR	ADP7-04SP2-H4SJ2-INS
7	PIN	ADP7-04SP2-H4SJ2-PIN

5.50±0.20 [.217±.008]  
(BODY TO INSULATOR)

0.25±0.10 [.010±.004]  
(BODY TO PIN)

UNLESS OTHERWISE SPECIFIED, DIMENSIONS ARE IN MILLIMETERS.

TOLERANCES ARE:

DECIMALS	ANGLES
X.X: ±0.3 [.01]	5°
X.XX: ±0.13 [.005]	
X.XXX: ±0.051 [.0020]	

PROPRIETARY NOTE

THIS DOCUMENT CONTAINS CONFIDENTIAL AND PROPRIETARY INFORMATION AND ALL DESIGN, MANUFACTURING, REPRODUCTION, USE, PATENT RIGHTS AND SALES RIGHTS ARE EXPRESSLY RESERVED BY SAMTEC, INC. THIS DOCUMENT SHALL NOT BE DISCLOSED, IN WHOLE OR PART, TO ANY UNAUTHORIZED PERSON OR ENTITY NOR REPRODUCED, TRANSFERRED OR INCORPORATED IN ANY OTHER PROJECT IN ANY MANNER WITHOUT THE EXPRESS WRITTEN CONSENT OF SAMTEC, INC.



520 PARK EAST BLVD, NEW ALBANY, IN 47150  
PHONE: 812-944-6733 FAX: 812-948-5047  
e-Mail info@SAMTEC.com code 55322

NOTES:

1. Ⓢ REPRESENTS A CRITICAL DIMENSION.
2. PRODUCT TO BE PACKAGED PER PACKING STANDARD CO-HD-WI-3040-M.

MATERIAL: DO NOT SCALE DRAWING SHEET SCALE: 3:1	DESCRIPTION: BNC PLUG TO HDBNC JACK STRAIGHT ADAPTER, 75 OHM
COUPLING NUT, BODY: BRASS	DWG. NO. ADP7-04SP2-H4SJ2
GASKET: SILICONE	BY: ALVIN W 07/20/2011 SHEET 1 OF 1
SPRING WASHER: SK5	
FLAT WASHER: BRASS	
INSULATOR: PTFE	
PIN: BeCu	