

REVISION C

0	AW	B Liu
8/15/2011 ECN-160625		
ISSUE FOR REVIEW		
A	EC	B Liu
11/3/2011 ECN-165661		
RELEASE FOR PRODUCTION		
B	EC	C SHELLY
1/29/2013 ECN-196871		
COMPONENT UPDATE: FRONT VIEW; ADP7-04SP2-BDY PER REVISION A		
C	EC	G Yang
4/19/2018 ECN-325847		
ADD EXISTING CUSTOMER ONLY WATERMARK.		

DESIGNED & DIMENSIONED IN MILLIMETERS [INCHES]

ADP7-04SP2-H4SP2

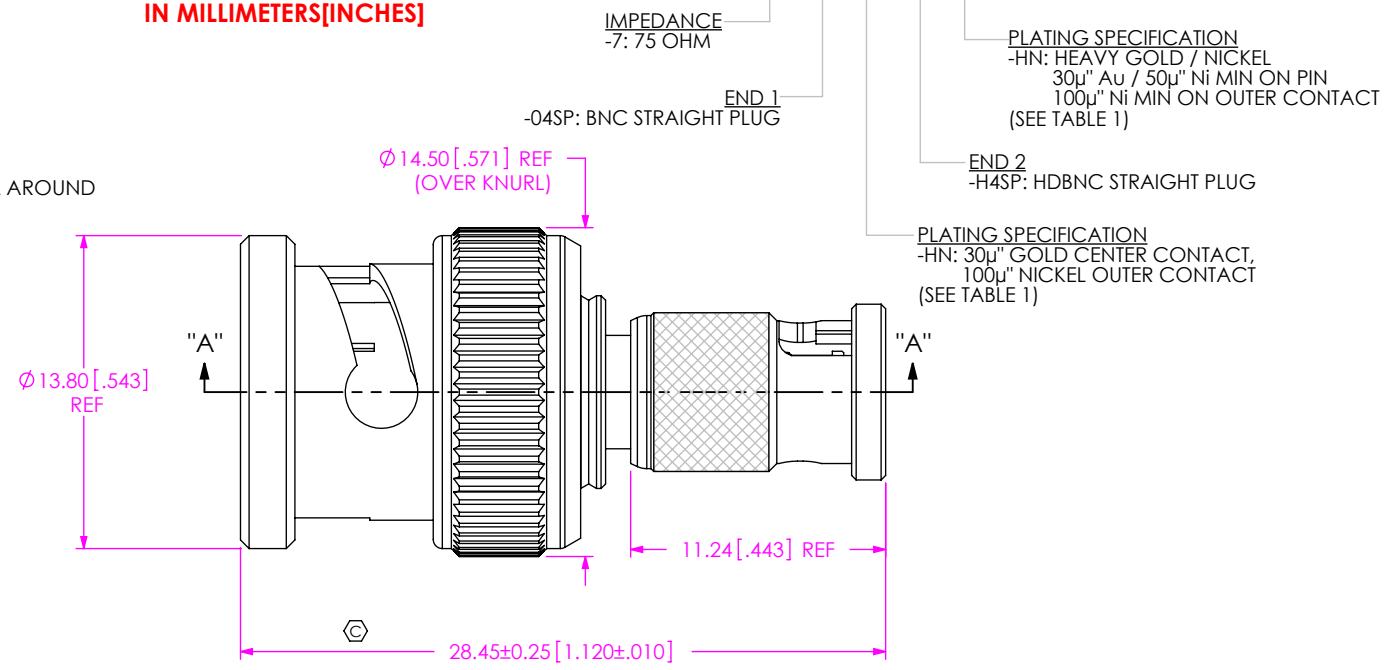
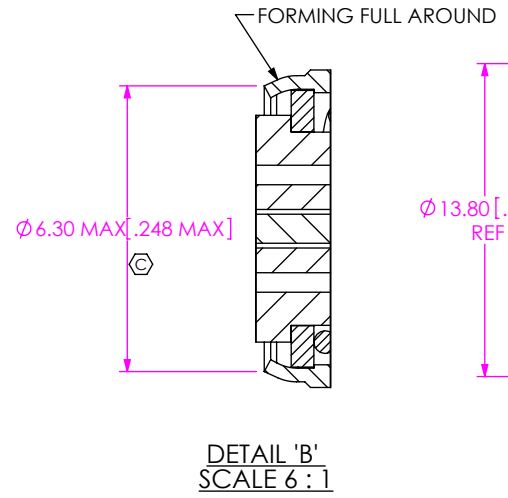
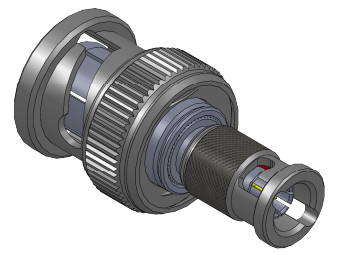
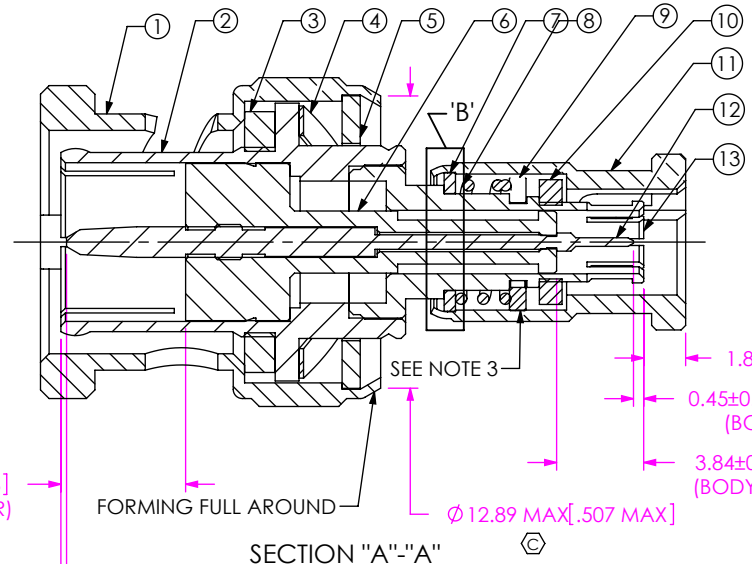

TABLE 1

ITEM	COMPONENT	-HN
1	COUPLING NUT	BNC-CNUT-001-N
2	BNC BODY	ADP7-04SP2-BDY
3	GASKET	BNC-GKT-001
4	SPRING WASHER	BNC-SWAS-001-N
5	FLAT WASHER	BNC-FWAS-001-N
6	INSULATOR	ADP7-04SP2-H4SP2-INS
7	FLAT WASHER	HDBNC-FWAS-001
8	SPRING	HDBNC-SPR-001
9	C-RING	HDBNC-CRNG-001-N
10	GASKET	HDBNC-GKT-001
11	COUPLING NUT	HDBNC-CNUT-002-N
12	PIN	ADP7-04SP2-H4SP2-PIN
13	HDBNC BODY	ADP7-H4SP2-BDY



NOTES:

- ⊕ REPRESENTS A CRITICAL DIMENSION.
- PRODUCT TO BE PACKAGED PER PACKING STANDARD CO-HD-WI-3040-M.
- PRESS C-RING INTO GROOVE.

UNLESS OTHERWISE SPECIFIED, DIMENSIONS ARE IN MILLIMETERS.

TOLERANCES ARE:

DECIMALS	ANGLES
X.X: ±0.3 [.01]	5°
X.XX: ±0.13 [.005]	
X.XXX: ±0.051 [.0020]	

PROPRIETARY NOTE

THIS DOCUMENT CONTAINS CONFIDENTIAL AND PROPRIETARY INFORMATION AND ALL DESIGN, MANUFACTURING, REPRODUCTION, USE, PATENT RIGHTS AND SALES RIGHTS ARE EXPRESSLY RESERVED BY SAMTEC, INC. THIS DOCUMENT SHALL NOT BE DISCLOSED, IN WHOLE OR PART, TO ANY UNAUTHORIZED PERSON OR ENTITY NOR REPRODUCED, TRANSFERRED OR INCORPORATED IN ANY OTHER PROJECT IN ANY MANNER WITHOUT THE EXPRESS WRITTEN CONSENT OF SAMTEC, INC.



520 PARK EAST BLVD., NEW ALBANY, IN 47150
PHONE: 812-944-6733 FAX: 812-948-5047
e-Mail: info@SAMTEC.com code 55322

MATERIAL: DO NOT SCALE DRAWING SHEET SCALE: 3:1

COUPLING NUT, BODIES, FLAT WASHER, C-RING, PIN: BRASS
GASKETS: SILICONE
SPRING WASHER: SK5
INSULATOR: PTFE
SPRING: STAINLESS STEEL

DESCRIPTION:
BNC PLUG TO HDBNC PLUG STRAIGHT ADAPTER, 75 OHM

DWG. NO.
ADP7-04SP2-H4SP2

BY: ALVIN W 07/20/2011 SHEET 1 OF 1