

1. CUSTOM JSOM FOR VITA MEZZANINE APPLICATIONS.
2. REPRESENTS A CRITICAL DIMENSION.
3. STANDOFFS TO BE USED WITH 1.57[.062] MIN THICK BOARDS.
4. STANDOFFS ARE DESIGNED 0.15MM LONGER THAN CONNECTOR STACK HEIGHTS TO ALLOW FOR PROCESSING VARIABLES.
5. TORQUE TO 2.5 – 3.5 IN*LBS TO SECURE FASTENER IN A STATIC ENVIRONMENT ASSUMING RECOMMENDED BOARD TO BOARD DISTANCES ARE ACHIEVED WITHOUT DAMAGE TO THE PCB, HARDWARE OR OTHER COMPONENTS.
6. COMPONENTS TO BE BULK PACKAGED IN SEPARATE BAGS AND SHOULD NOT LIST INDIVIDUAL COMPONENT QUANTITY ON THE LABEL. ALL COMPONENT BAGS ARE TO BE PACKAGED IN A LARGER BAG WITH THE FINAL PART NUMBER QUANTITY OF ASSEMBLIES ON THE LABEL.

DO NOT
SCALE FROM
THIS PRINT

BOARD STACK HEIGHT

- 01: 8.650 (WITH THREAD LOCKING SCREW)
- 02: 10.150 (WITH THREAD LOCKING SCREW)
- 03: 12.150 (WITH THREAD LOCKING SCREW)
- 04: 8.650 (WITHOUT THREAD LOCKING SCREW)
- 05: 10.150 (WITHOUT THREAD LOCKING SCREW)
- 06: 12.150 (WITHOUT THREAD LOCKING SCREW)

BY SIGNING THIS DOCUMENT YOU ARE ACCEPTING THE CONDITIONS SET WITHIN. YOUR REQUIREMENTS MUST BE LISTED WITHIN THIS DRAWING. WHERE NO DIRECTION FROM THE CUSTOMER IS IDENTIFIED SAMTEC'S PROCESS REQUIREMENTS WILL BE USED.

DATE: _____
 COMPANY: _____
 CUSTOMER SIGNATURE: _____
 PRINTED NAME: _____
 PHONE NO: _____
 EXCEPTIONS: _____

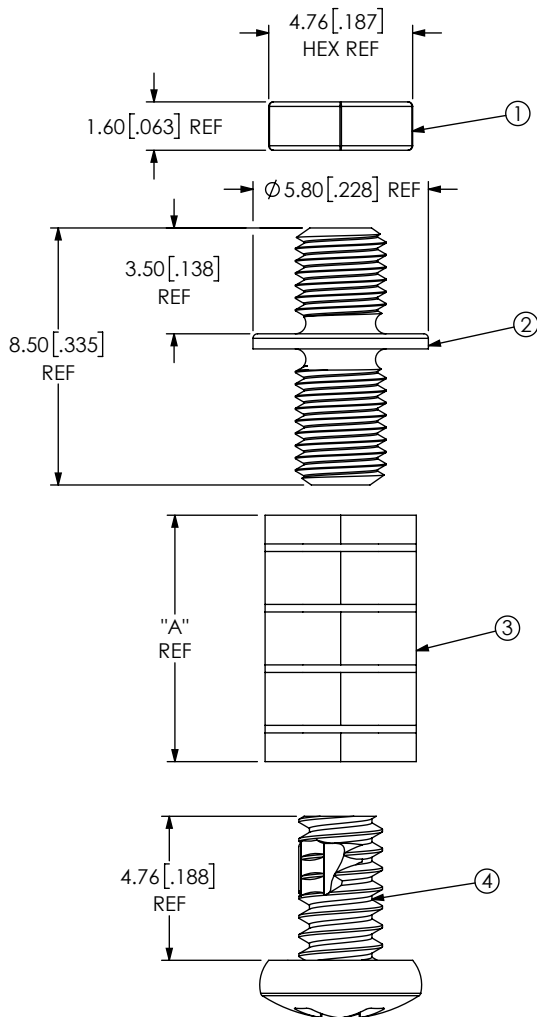

LEAD STYLE	JSOM-B-XX.XX-02	MS-01-02-X	"A"	"B"
-01	JSOM-B-08.15-02	MS-01-02-L	8.15	8.65
-02	JSOM-B-09.65-02	MS-01-02-L	9.65	10.15
-03	JSOM-B-11.65-02	MS-01-02-L	11.65	12.15
-04	JSOM-B-08.15-02	MS-01-02	8.15	8.65
-05	JSOM-B-09.65-02	MS-01-02	9.65	10.15
-06	JSOM-B-11.65-02	MS-01-02	11.65	12.15

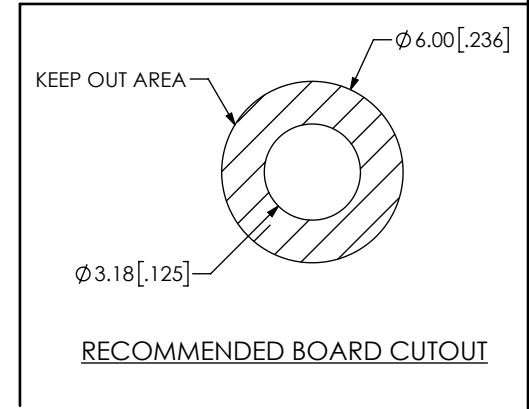
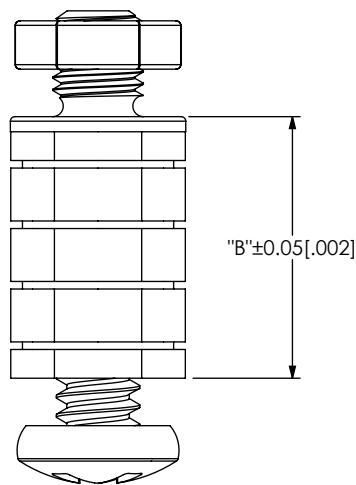

RECOMMENDED BOARD CUTOUT

ITEM NO.	PART NUMBER	QUANTITY	MATERIAL
1	SN-01-02	1.0000	303 STAINLESS STEEL
2	ASP-223663-01-C	1.0000	303 STAINLESS STEEL
3	JSOM-B-XX.XX-02 (SEE TABLE 1)	1.0000	303 STAINLESS STEEL
4	MS-01-02-X (SEE TABLE 1)	1.0000	303 STAINLESS STEEL

UNLESS OTHERWISE SPECIFIED, DIMENSIONS ARE IN MILLIMETERS.
 TOLERANCES ARE:
 DECIMALS ANGLES
 X.X: ±0.3 [.01] 2°
 X.XX: ±0.13 [.005]
 X.XXX: ±0.051 [.0020]

PROPRIETARY NOTE
 THIS DOCUMENT CONTAINS CONFIDENTIAL AND PROPRIETARY INFORMATION AND ALL DESIGN, MANUFACTURING, REPRODUCTION, USE, PATENT RIGHTS AND SALES RIGHTS ARE EXPRESSLY RESERVED BY SAMTEC, INC. THIS DOCUMENT SHALL NOT BE DISCLOSED, IN WHOLE OR PART, TO ANY UNAUTHORIZED PERSON OR ENTITY NOR REPRODUCED, TRANSFERRED OR INCORPORATED IN ANY OTHER PROJECT IN ANY MANNER WITHOUT THE EXPRESS WRITTEN CONSENT OF SAMTEC, INC.



520 PARK EAST BLVD, NEW ALBANY, IN 47150
 PHONE: 812-944-6733 FAX: 812-948-5047
 e-Mail: info@SAMTEC.com code 53322

DO NOT SCALE DRAWING SHEET SCALE: 4:1

DESCRIPTION:
 # 4-40 MICRO JACK SCREW STAND-OFF
 DWG. NO.
 ASP-199167-XX
 BY: SHERRY W 4/17/2017 SHEET 1 OF 1