

REVISION D

DO NOT SCALE FROM THIS PRINT

- NOTES:
1. STANDARD PART SET UP AS ASP.
LIKE PART: SEAM-40-02.0-STL-14-1-A-K-TR
 2. REPRESENTS A CRITICAL DIMENSION.
 3. MINIMUM PUSHOUT FORCE: 0.50 LBS.
 4. MEASURED FIRST & LAST POSITIONS ONLY, ALL ROWS.
 5. DIMENSION MUST BE MEASURED IN THE FOUR OUTSIDE CORNERS USING INSPECTION FIXTURE AT-1817-836-2, USE CO-AU-WI-2003-M FOR PROCESS.
 6. PARTS TO BE PACKAGED IN TAPE & REEL.
ATTACH LABEL "SEAX-0001" TO EACH TAPE & REEL PACKAGE.
 7. FOR QUANTITIES UP TO 49 PIECES, NO LEADER, TRAILER, OR REEL WILL BE SUPPLIED.
FOR QUANTITIES 50-124, NO LEADER OR TRAILER WILL BE SUPPLIED.
 8. ORDERS WILL BE PACKAGED ACCORDING TO THE SAMTEC PACKAGING EFFICIENCY STANDARDS (SPES) FOUND ON WWW.SAMTEC.COM.

SOME CENTER FEATURES NOT SHOWN FOR CLARITY

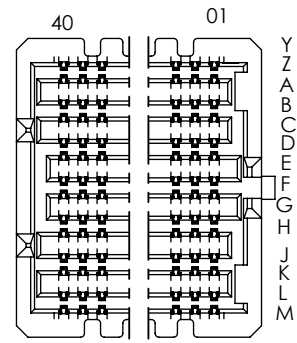
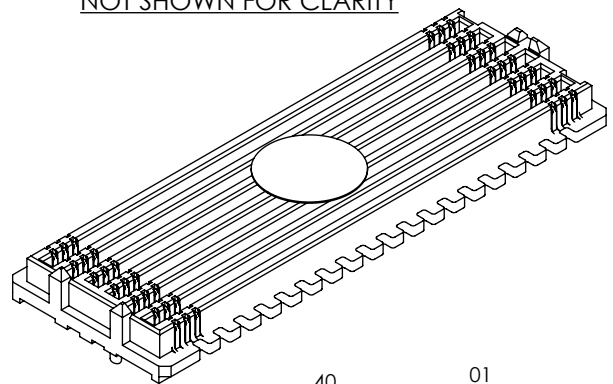

-14 ROW DETAIL

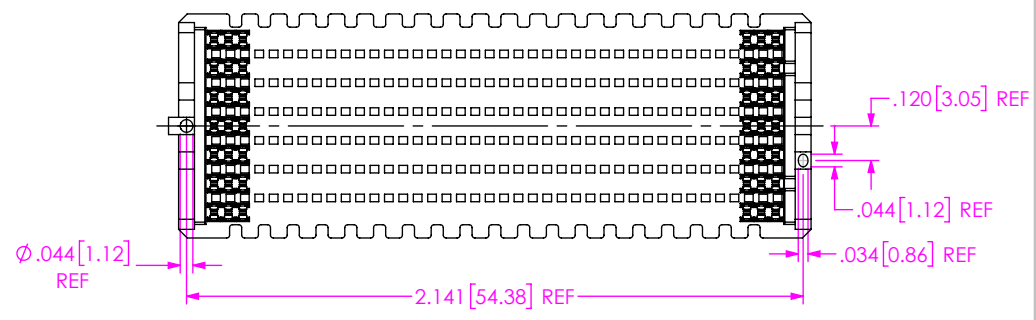
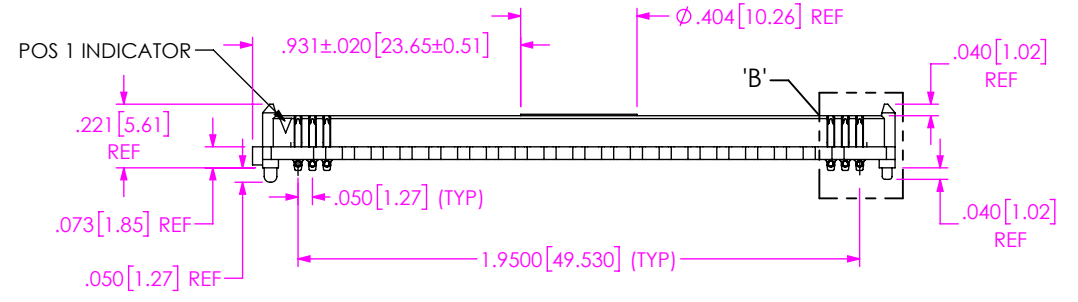
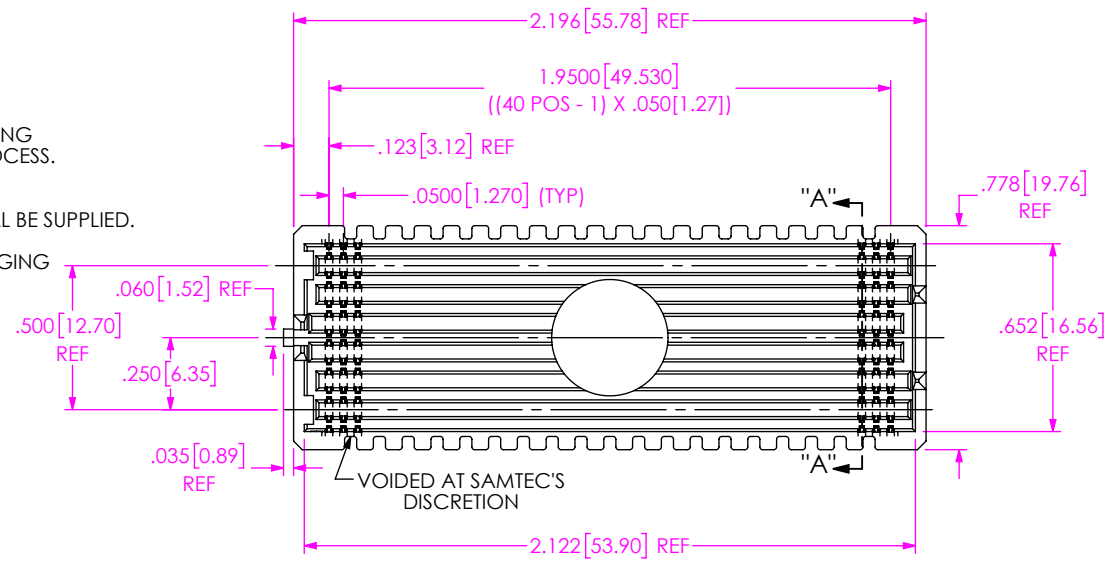

BY SIGNING THIS DOCUMENT YOU ARE ACCEPTING THE CONDITIONS SET WITHIN. YOUR REQUIREMENTS MUST BE LISTED WITHIN THIS DRAWING. WHERE NO DIRECTION FROM THE CUSTOMER IS IDENTIFIED SAMTEC'S PROCESS REQUIREMENTS WILL BE USED.

DATE: _____
 COMPANY: _____
 CUSTOMER SIGNATURE: _____
 PRINTED NAME: _____
 PHONE No.: _____
 EXCEPTIONS: _____

UNLESS OTHERWISE SPECIFIED, DIMENSIONS ARE IN INCHES. TOLERANCES ARE: DECIMALS ANGLES .XX: ±.01 [0.3] .XXX: ±.005 [0.13] .XXXX: ±.0020 [0.051]	* PROPRIETARY NOTE THIS DOCUMENT CONTAINS CONFIDENTIAL AND PROPRIETARY INFORMATION AND ALL DESIGN, MANUFACTURING, REPRODUCTION, USE, PATENT RIGHTS AND SALES RIGHTS ARE EXPRESSLY RESERVED BY SAMTEC, INC. THIS DOCUMENT SHALL NOT BE DISCLOSED, IN WHOLE OR PART, TO ANY UNAUTHORIZED PERSON OR ENTITY NOR REPRODUCED, TRANSFERRED OR INCORPORATED IN ANY OTHER PROJECT IN ANY MANNER WITHOUT THE EXPRESS WRITTEN CONSENT OF SAMTEC, INC.		
		520 PARK EAST BLVD, NEW ALBANY, IN 47150 PHONE: 812-944-6733 FAX: 812-948-5047 e-Mail: info@SAMTEC.com code 55322	
DO NOT SCALE DRAWING SHEET SCALE: 3:2		DESCRIPTION: MODIFIED SEAM ASSEMBLY	
PLATING: CONTACT AREA: .00030 GOLD OVER .00050 NICKEL REMAINDER: .000200 REF TIN/LEAD (90/10) OVER .00050 NICKEL		DWG. NO. ASP-208521-01	
SOLDER COMP: 63% TIN / 37% LEAD		BY: J. BROWNING 01/21/2019 SHEET 1 OF 4	
c:\enterprise\ault\DWG\MISC\MKTG\ASP-208521-01-MKT.SLDDRW			

ITEM NO.	PART NUMBER	QUANTITY	MATERIAL
1	SEAM-40-02.0-14-A	1.0000	LCP, UL 94 VO, COLOR: BLACK
2	NEW-SUB-T-1M36-02.0-STL-1	560.00	COPPER ALLOY / LEADED SOLDER
3	K-DOT-.404-500-.005	1.0000	POLYIMIDE FILM
4	CT-SEAM185MS	.00571	CONDUCTIVE POLYMER

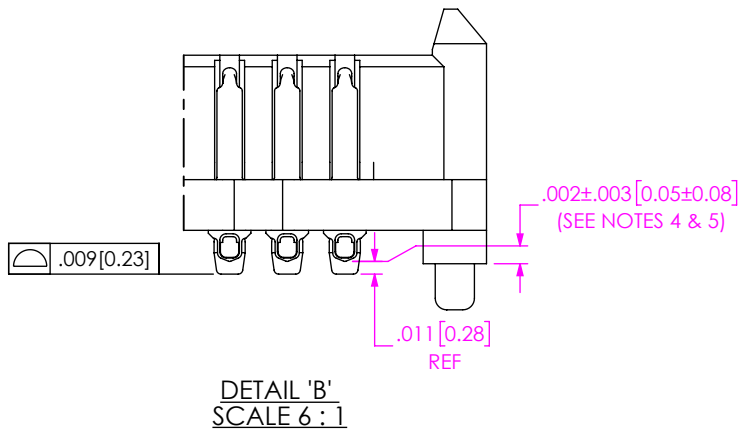
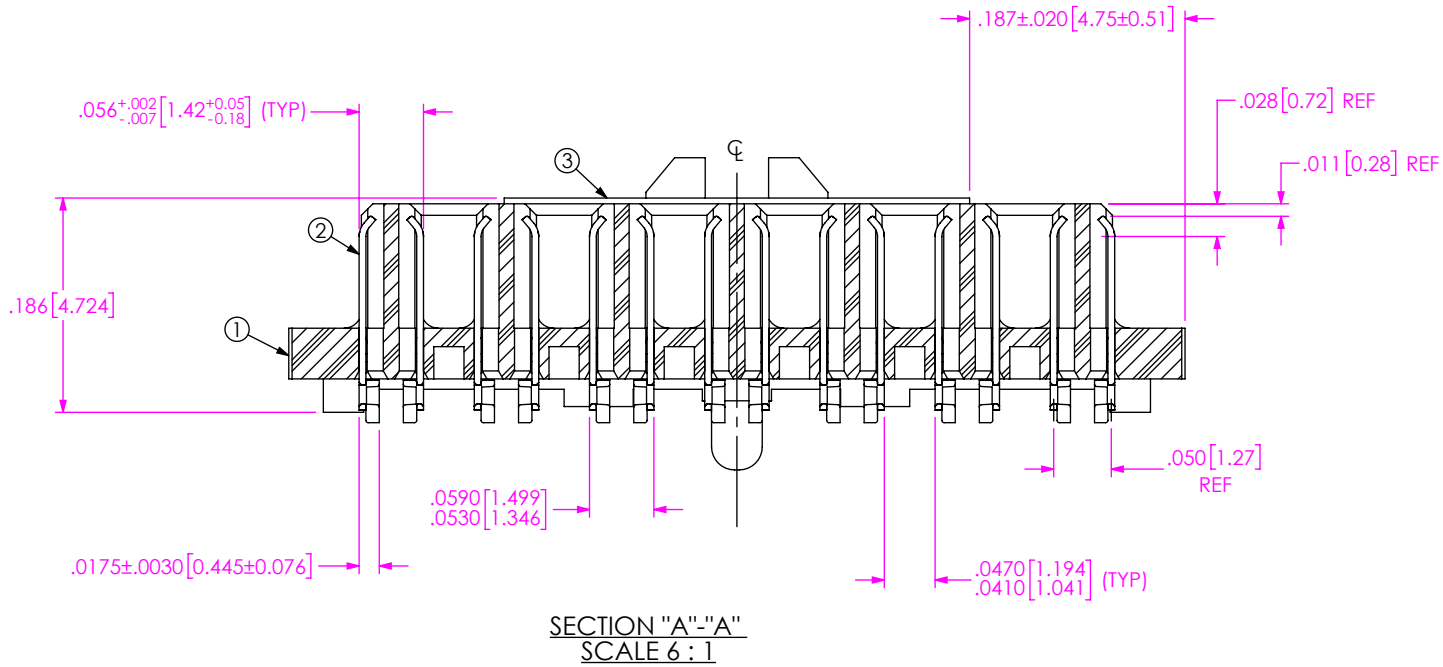

PROPRIETARY NOTE
 THIS DOCUMENT CONTAINS CONFIDENTIAL AND PROPRIETARY INFORMATION AND ALL DESIGN, MANUFACTURING, REPRODUCTION, USE, PATENT RIGHTS AND SALES RIGHTS ARE EXPRESSLY RESERVED BY SAMTEC, INC. THIS DOCUMENT SHALL NOT BE DISCLOSED, IN WHOLE OR PART, TO ANY UNAUTHORIZED PERSON OR ENTITY NOR REPRODUCED, TRANSFERRED OR INCORPORATED IN ANY OTHER PROJECT IN ANY MANNER WITHOUT THE EXPRESS WRITTEN CONSENT OF SAMTEC, INC.

DO NOT SCALE DRAWING

SHEET SCALE: 2:1



520 PARK EAST BLVD. NEW ALBANY, IN 47150
 PHONE: 812-944-6733 FAX: 812-948-5047
 e-Mail info@SAMTEC.com code 55322

DESCRIPTION:
 MODIFIED SEAM ASSEMBLY

DWG. NO.
 ASP-208521-01

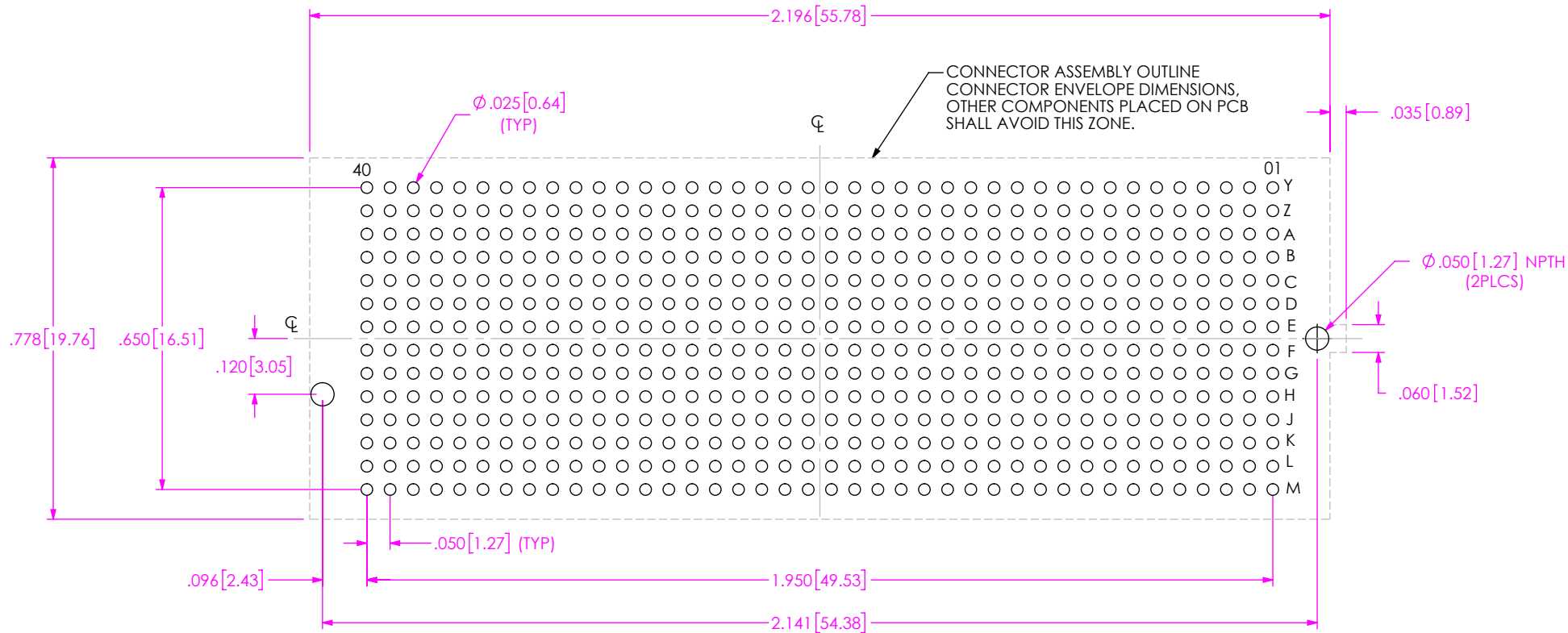

RECOMMENDED PCB LAYOUT
ALL DIMENSIONS ARE SYMMETRIC ABOUT THE CENTERLINE

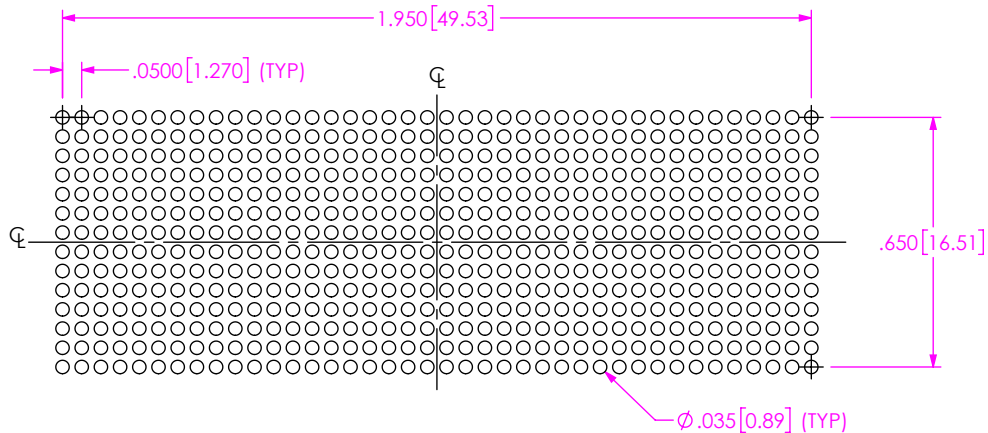

RECOMMENDED STENCIL LAYOUT
ALL DIMENSIONS ARE SYMMETRIC ABOUT THE CENTERLINE
STENCIL TO BE .0060 [0.152] THICK

PROPRIETARY NOTE
THIS DOCUMENT CONTAINS CONFIDENTIAL AND PROPRIETARY INFORMATION AND ALL DESIGN, MANUFACTURING, REPRODUCTION, USE, PATENT RIGHTS AND SALES RIGHTS ARE EXPRESSLY RESERVED BY SAMTEC, INC. THIS DOCUMENT SHALL NOT BE DISCLOSED, IN WHOLE OR PART, TO ANY UNAUTHORIZED PERSON OR ENTITY NOR REPRODUCED, TRANSFERRED OR INCORPORATED IN ANY OTHER PROJECT IN ANY MANNER WITHOUT THE EXPRESS WRITTEN CONSENT OF SAMTEC, INC.



520 PARK EAST BLVD., NEW ALBANY, IN 47150
PHONE: 812-944-6733 FAX: 812-948-5047
e-Mail: info@SAMTEC.com code 55322

SHEET SCALE: 3:1

DESCRIPTION: MODIFIED SEAM ASSEMBLY

DWG. NO. ASP-208521-01

BY: J. BROWNING 01/21/2019 SHEET 3 OF 4

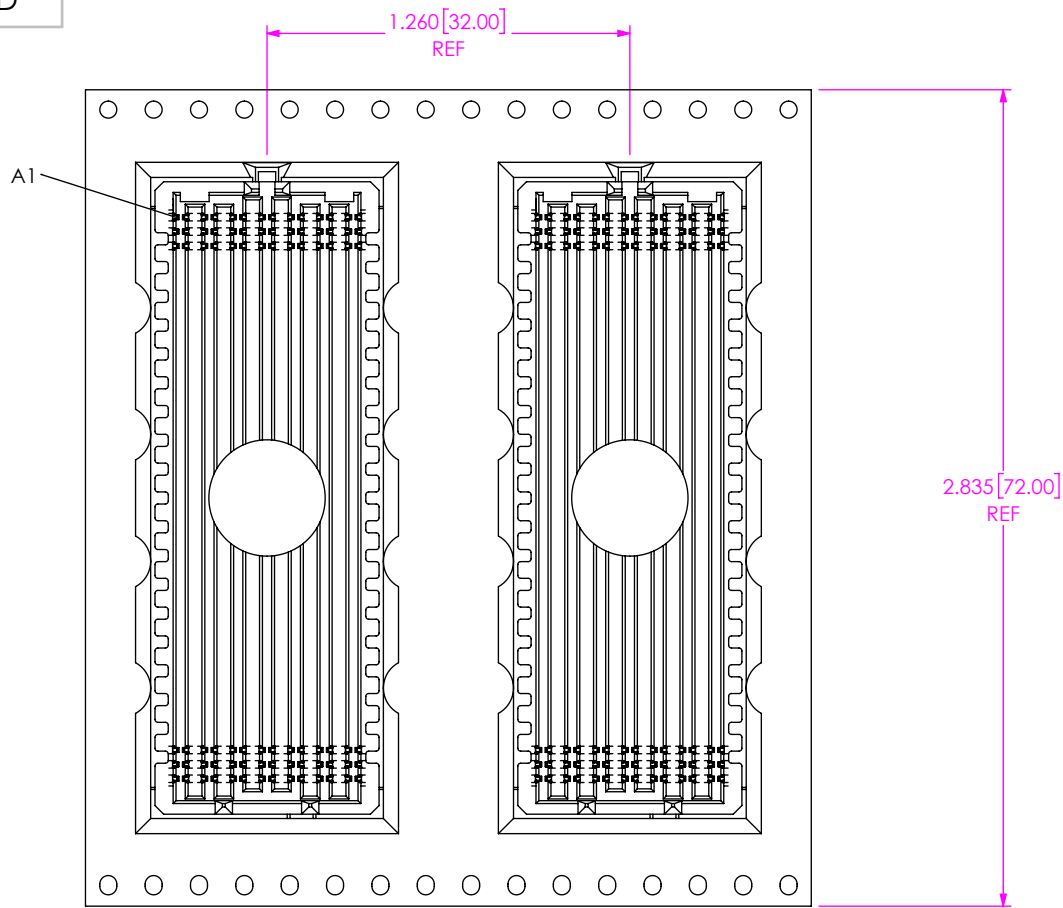

USER DIRECTION OF UN-REELING →
POCKET NOT DETAILED

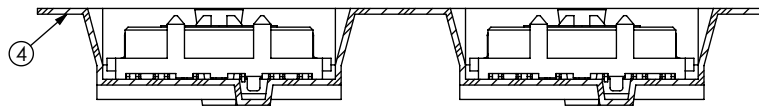

PACKAGING VIEW

PROPRIETARY NOTE

THIS DOCUMENT CONTAINS CONFIDENTIAL AND PROPRIETARY INFORMATION AND ALL DESIGN, MANUFACTURING, REPRODUCTION, USE, PATENT RIGHTS AND SALES RIGHTS ARE EXPRESSLY RESERVED BY SAMTEC, INC. THIS DOCUMENT SHALL NOT BE DISCLOSED, IN WHOLE OR PART, TO ANY UNAUTHORIZED PERSON OR ENTITY NOR REPRODUCED, TRANSFERRED OR INCORPORATED IN ANY OTHER PROJECT IN ANY MANNER WITHOUT THE EXPRESS WRITTEN CONSENT OF SAMTEC, INC.



520 PARK EAST BLVD., NEW ALBANY, IN 47150
PHONE: 812-944-6733 FAX: 812-948-5047
e-Mail info@SAMTEC.com code 55322

SHEET SCALE: 3:1

DESCRIPTION:
MODIFIED SEAM ASSEMBLY

DWG. NO.
ASP-208521-01

BY: J. BROWNING 01/21/2019 SHEET 4 OF 4