

REVISION D

BY SIGNING THIS DOCUMENT YOU ARE ACCEPTING THE CONDITIONS SET WITHIN. YOUR REQUIREMENTS MUST BE LISTED WITHIN THIS DRAWING. WHERE NO DIRECTION FROM THE CUSTOMER IS IDENTIFIED SAMTEC'S PROCESS REQUIREMENTS WILL BE USED.

DATE: _____
 COMPANY: _____
 CUSTOMER SIGNATURE: _____
 PRINTED NAME: _____
 PHONE No.: _____
 EXCEPTIONS: _____

- NOTES:
1. MINIMUM PUSHOUT FORCE: 1.6N
 2. PARTS TO BE PACKAGED IN TAPE & REEL.
 3. SEE SHT 2 FOR PROCESSING INFORMATION.
 4. ATTACH LABEL -4X2 TO EACH REEL.
 5. ORDERS WILL BE PACKAGED ACCORDING TO THE SAMTEC PACKAGING EFFICIENCY STANDARDS (SPES) FOUND ON WWW.SAMTEC.COM.

**DESIGNED AND DIMENSIONED IN MILLIMETERS[INCHES]
 ALL DIMENSIONS REFERENCE EXCEPT AS SHOWN**

SOME CENTER FEATURES
 NOT SHOWN FOR CLARITY

DO NOT
 SCALE FROM
 THIS PRINT

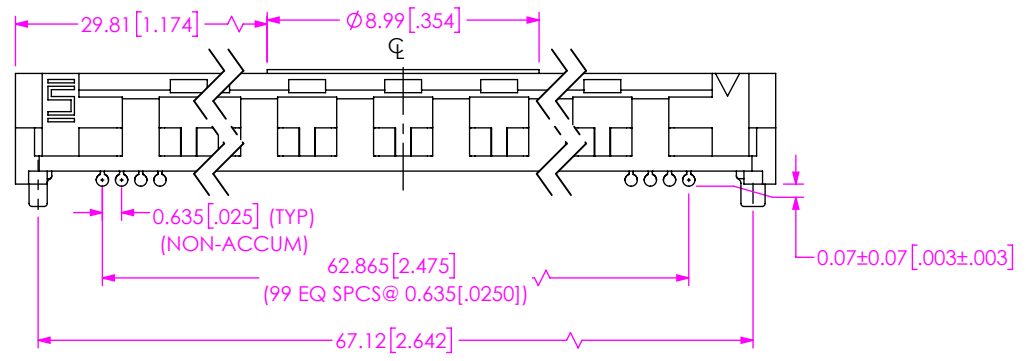
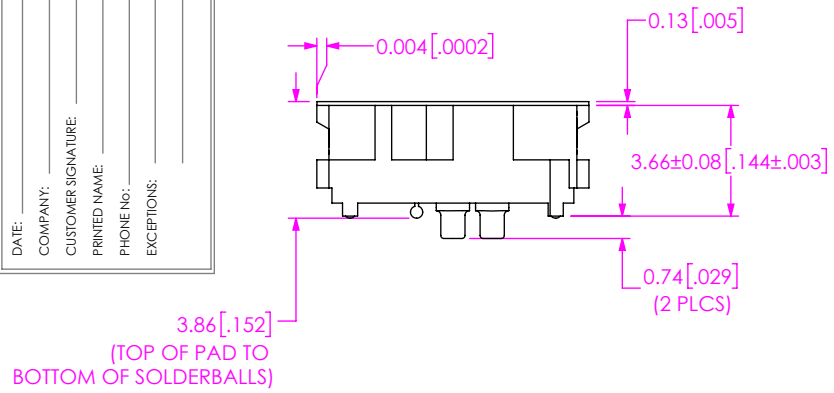
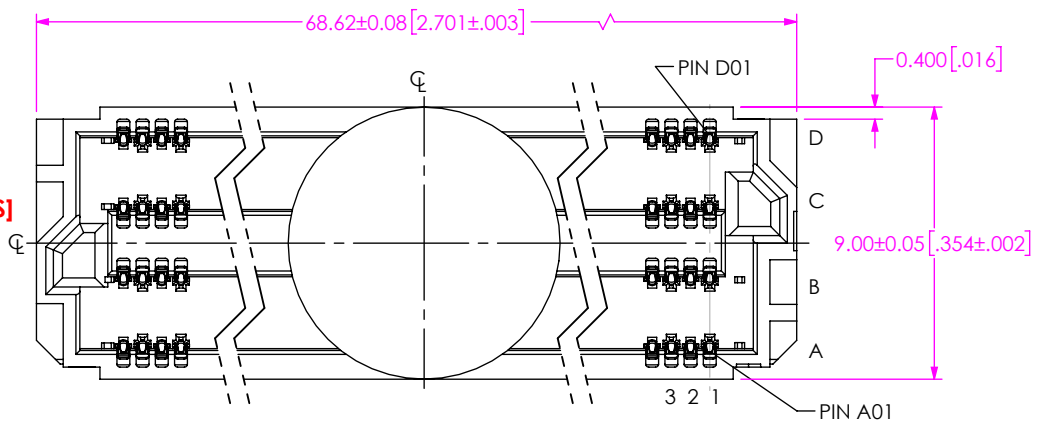
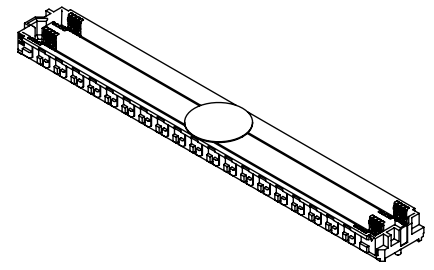
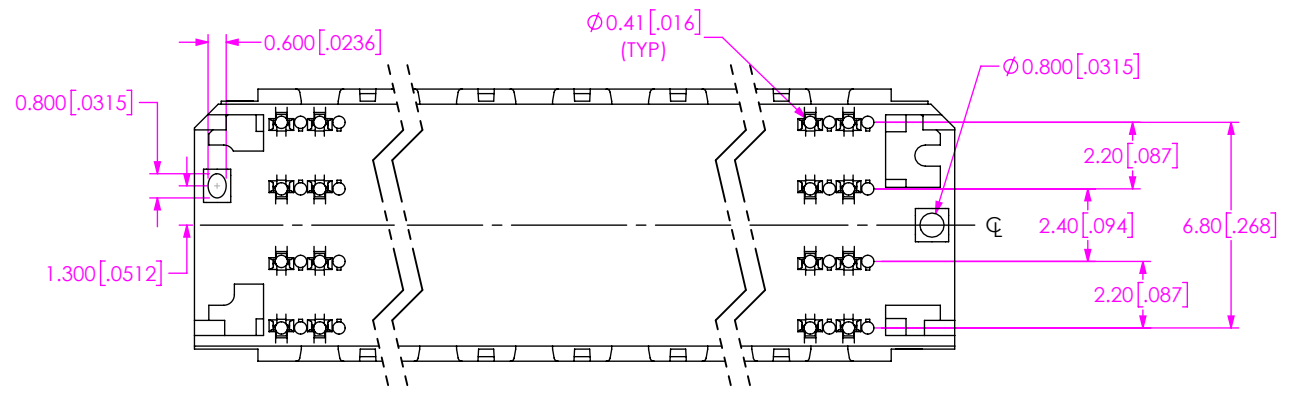

FIG 1
 (ASP-209946-02 SHOWN)



PROPRIETARY NOTE
 THIS DOCUMENT CONTAINS CONFIDENTIAL AND PROPRIETARY INFORMATION AND ALL DESIGN, MANUFACTURING, REPRODUCTION, USE, PATENT RIGHTS AND SALES RIGHTS ARE EXPRESSLY RESERVED BY SAMTEC, INC. THIS DOCUMENT SHALL NOT BE DISCLOSED, IN WHOLE OR PART, TO ANY UNAUTHORIZED PERSON OR ENTITY NOR REPRODUCED, TRANSFERRED OR INCORPORATED IN ANY OTHER PROJECT IN ANY MANNER WITHOUT THE EXPRESS WRITTEN CONSENT OF SAMTEC, INC.

DO NOT SCALE DRAWING SHEET SCALE: 4:1

MATERIAL:
 INSULATOR: LCP, COLOR: NATURAL
 CONTACT: COPPER ALLOY
 PLATING:
 CONTACT AREA: .000030" GOLD OVER .000050" NICKEL
 REMAINDER: .000200" REF TIN OVER .000050" NICKEL

samtec

520 PARK EAST BLVD, NEW ALBANY, IN 47150
 PHONE: 812-944-6733 FAX: 812-948-5047
 e-Mail: info@SAMTEC.com code 53322

DESCRIPTION:
 CUSTOM COM HPC FEMALE ASSEMBLY

DWG. NO.
ASP-209946-02

BY: R. CURRY 11/05/2020 SHEET 1 OF 8

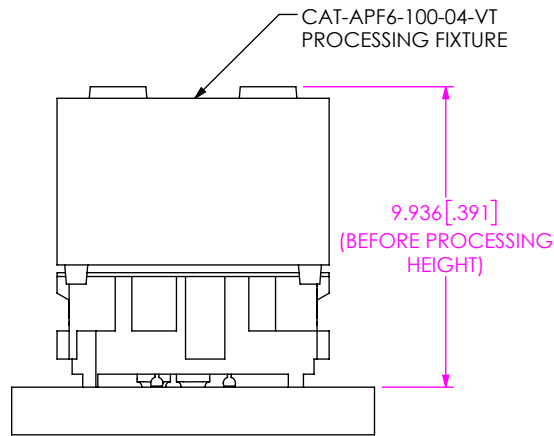

PROCESSING VIEW
 DIMENSION INDICATES CONNECTOR/FIXTURE HEIGHT ON PCB
 TO GUARANTEE ENOUGH REFLOW OVEN WORKING SPACE.
 DIMENSION, PCB THICKNESS, AND THE HEIGHT OF THE COMPONENTS
 ON THE OTHER SIDE OF THE BOARD NEED TO BE CONSIDERED.

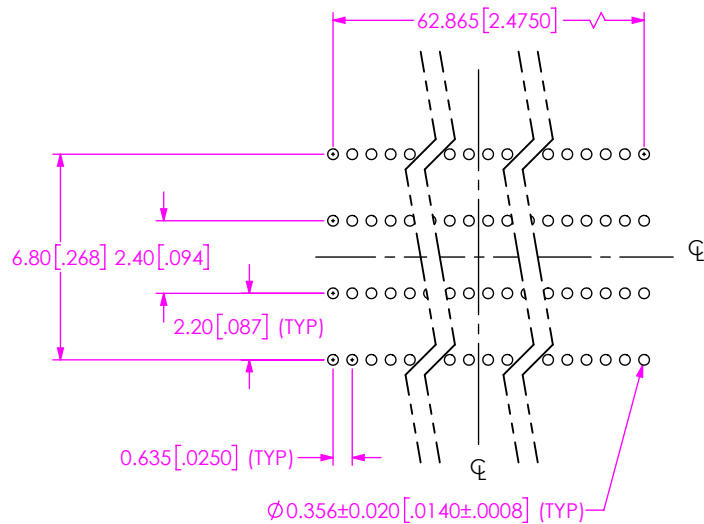

RECOMMENDED STENCIL LAYOUT
 ALL DIMENSIONS SYMMETRIC ABOUT CENTERLINE
 (STENCIL TO BE 0.125 [.0050] THICK)

PROPRIETARY NOTE
 THIS DOCUMENT CONTAINS CONFIDENTIAL AND
 PROPRIETARY INFORMATION AND ALL DESIGN,
 MANUFACTURING, REPRODUCTION, USE, PATENT RIGHTS
 AND SALES RIGHTS ARE EXPRESSLY RESERVED BY SAMTEC,
 INC. THIS DOCUMENT SHALL NOT BE DISCLOSED, IN WHOLE
 OR PART, TO ANY UNAUTHORIZED PERSON OR ENTITY NOR
 REPRODUCED, TRANSFERRED OR INCORPORATED IN ANY
 OTHER PROJECT IN ANY MANNER WITHOUT THE EXPRESS
 WRITTEN CONSENT OF SAMTEC, INC.



520 PARK EAST BLVD., NEW ALBANY, IN 47150
 PHONE: 812-944-6733 FAX: 812-948-5047
 e-Mail info@SAMTEC.com code 55322

SHEET SCALE: 1:1

DESCRIPTION:
 CUSTOM COM HPC FEMALE ASSEMBLY

DWG. NO.
 ASP-209946-02

BY: R. CURRY 11/05/2020 SHEET 2 OF 8

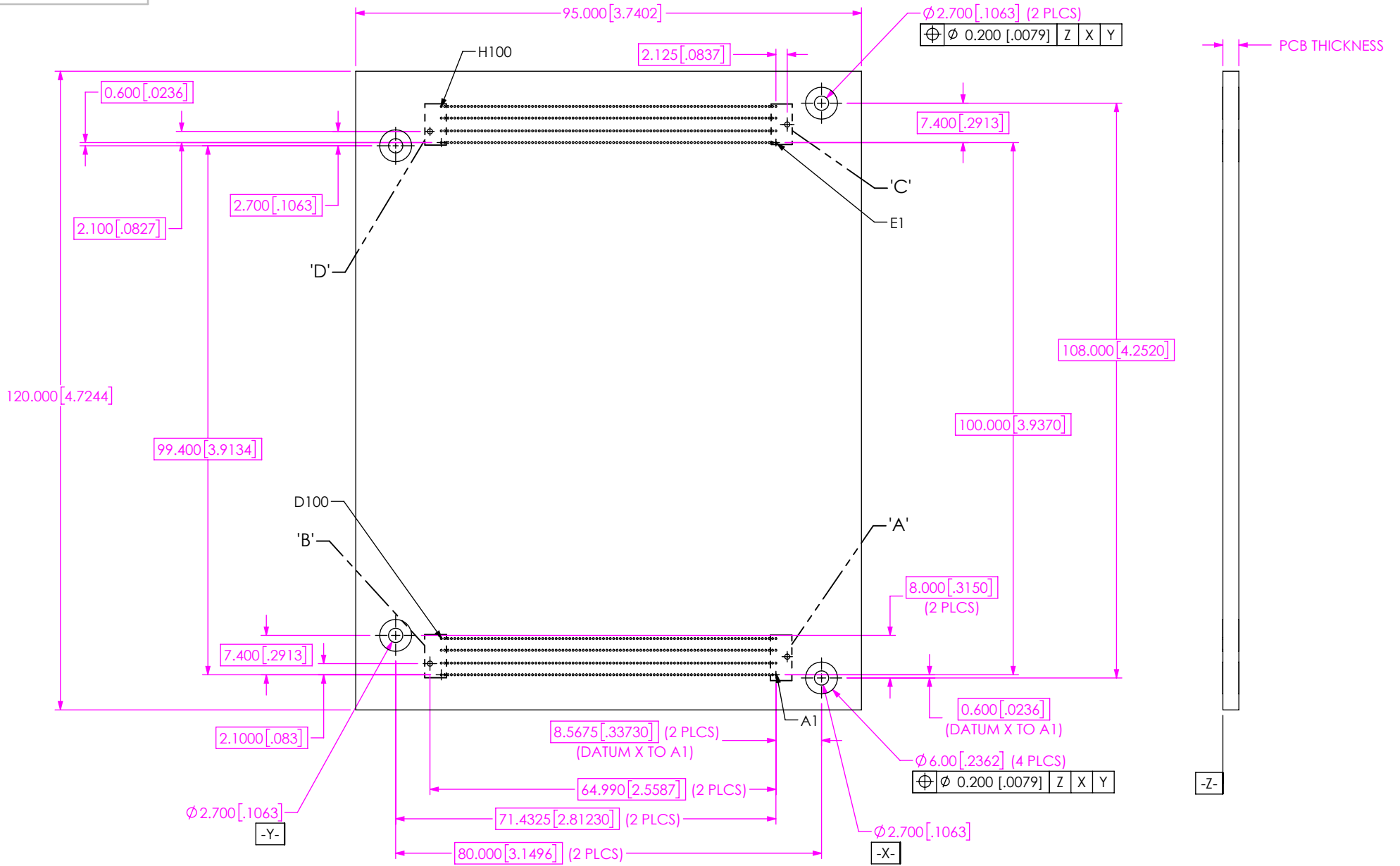
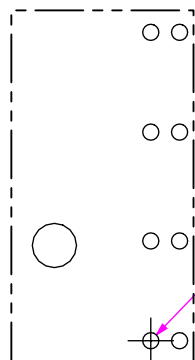

FIG 2
COM-HPC® MODULE SIZE A
((RECOMMENDED PCB LAYOUT FOR COM-HPC®))

<p>PROPRIETARY NOTE</p> <p>THIS DOCUMENT CONTAINS CONFIDENTIAL AND PROPRIETARY INFORMATION AND ALL DESIGN, MANUFACTURING, REPRODUCTION, USE, PATENT RIGHTS AND SALES RIGHTS ARE EXPRESSLY RESERVED BY SAMTEC, INC. THIS DOCUMENT SHALL NOT BE DISCLOSED, IN WHOLE OR PART, TO ANY UNAUTHORIZED PERSON OR ENTITY NOR REPRODUCED, TRANSFERRED OR INCORPORATED IN ANY OTHER PROJECT IN ANY MANNER WITHOUT THE EXPRESS WRITTEN CONSENT OF SAMTEC, INC.</p>	<p>DESCRIPTION: CUSTOM COM HPC FEMALE ASSEMBLY</p>	
	<p>DWG. NO. ASP-209946-02</p>	
	<p>BY: R. CURRY</p>	<p>11/05/2020</p>



$\varnothing 0.356 \pm 0.030 [0.140 \pm .0012]$

\varnothing	0.100	[.0039]	Z	U	V
\varnothing	0.200	[.0079]	Z	S	T
-T-					

DETAIL 'D'
SCALE 6 : 1

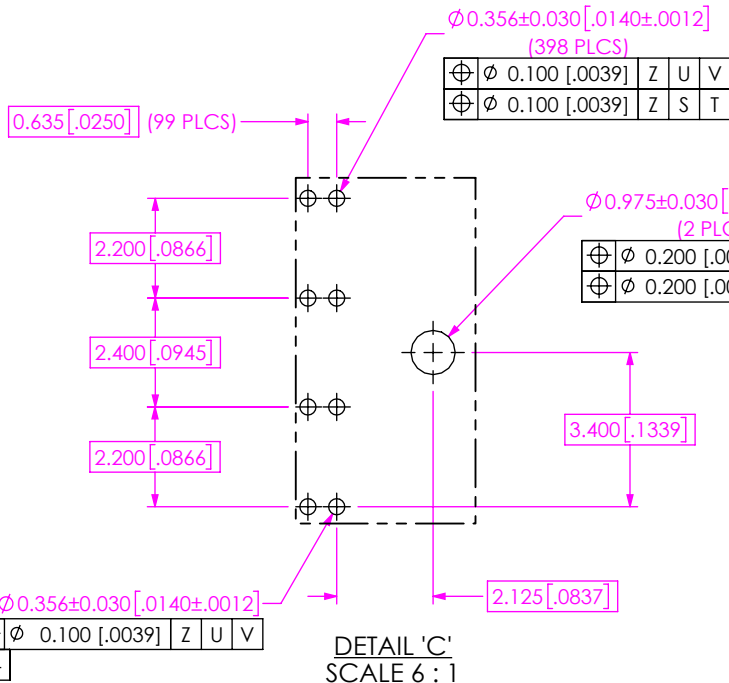

$\varnothing 0.356 \pm 0.030 [0.140 \pm .0012]$

\varnothing	0.100	[.0039]	Z	U	V
-S-					

DETAIL 'C'
SCALE 6 : 1

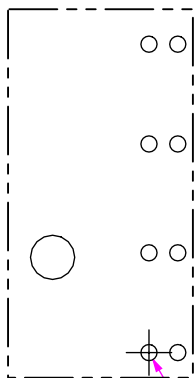

$\varnothing 0.356 \pm 0.030 [0.140 \pm .0012]$

\varnothing	0.200	[.0079]	Z	X	Y
\varnothing	0.100	[.0039]	Z	U	
-V-					

DETAIL 'B'
SCALE 6 : 1

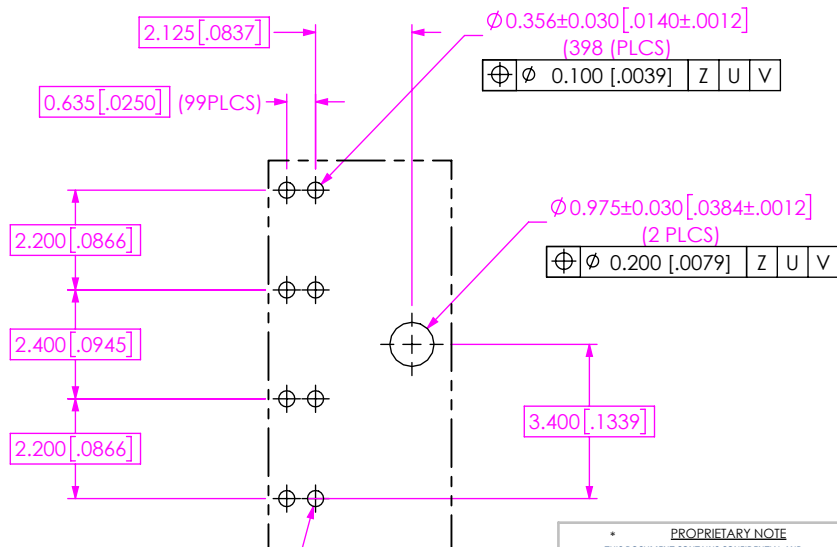

$\varnothing 0.356 \pm 0.030 [0.140 \pm .0012]$

\varnothing	0.200	[.0079]	Z	X	Y
-U-					

DETAIL 'A'
SCALE 6 : 1

PROPRIETARY NOTE
 THIS DOCUMENT CONTAINS CONFIDENTIAL AND PROPRIETARY INFORMATION AND ALL DESIGN, MANUFACTURING, REPRODUCTION, USE, PATENT RIGHTS AND SALES RIGHTS ARE EXPRESSLY RESERVED BY SAMTEC, INC. THIS DOCUMENT SHALL NOT BE DISCLOSED, IN WHOLE OR PART, TO ANY UNAUTHORIZED PERSON OR ENTITY NOR REPRODUCED, TRANSFERRED OR INCORPORATED IN ANY OTHER PROJECT IN ANY MANNER WITHOUT THE EXPRESS WRITTEN CONSENT OF SAMTEC, INC.

SHEET SCALE: 6:1



520 PARK EAST BLVD., NEW ALBANY, IN 47150
 PHONE: 812-944-6733 FAX: 812-948-5047
 e-Mail info@SAMTEC.com code 55322

DESCRIPTION:
 CUSTOM COM HPC FEMALE ASSEMBLY

DWG. NO.
ASP-209946-02

BY: R. CURRY 11/05/2020 SHEET 4 OF 8

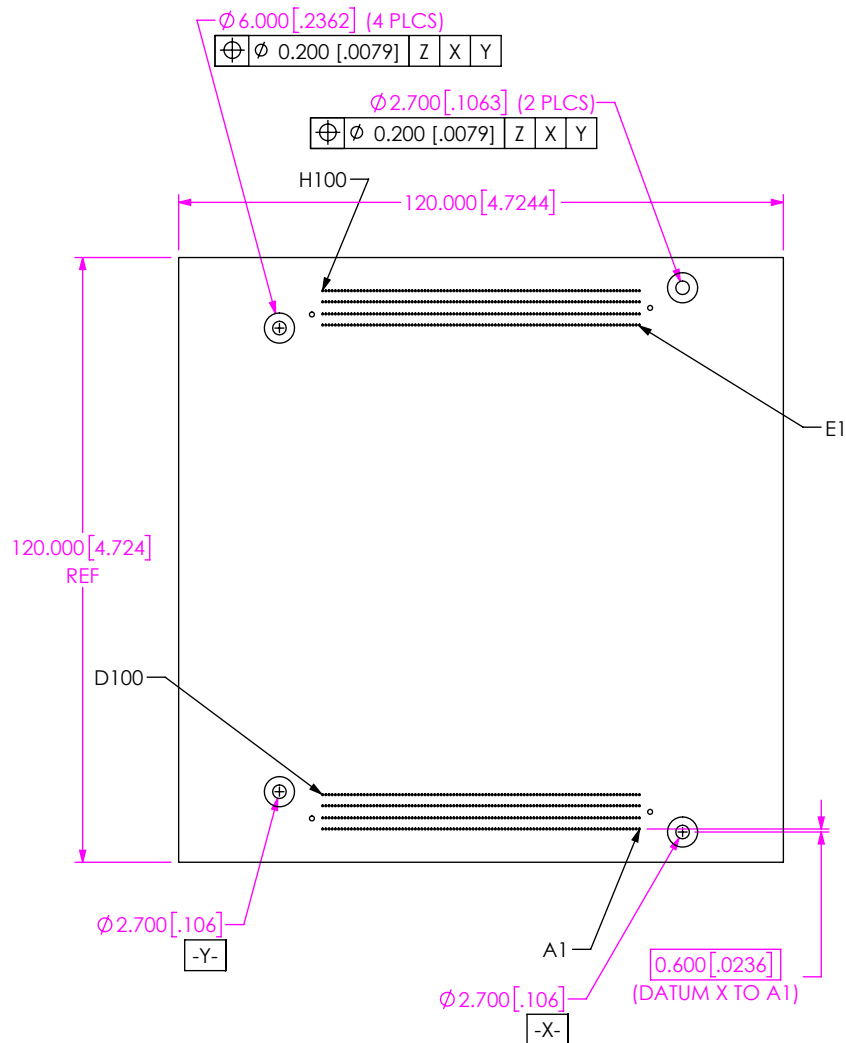

FIG 3
COM-HPC® MODULE SIZE B
(SAME AS FIG 2, EXCEPT AS SHOWN)
(RECOMMENDED PCB LAYOUT FOR COM-HPC)

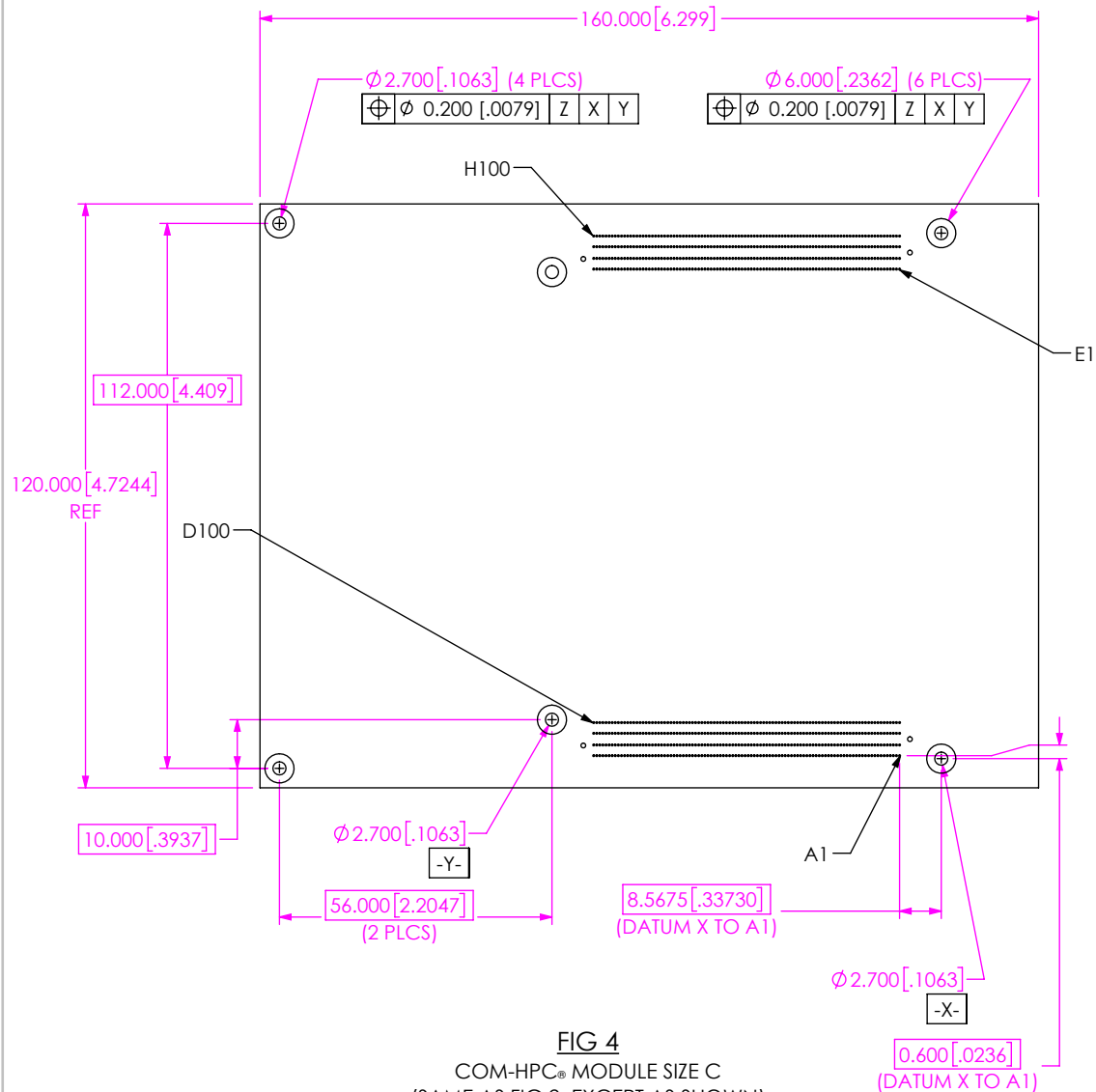



FIG 4
COM-HPC® MODULE SIZE C
(SAME AS FIG 2, EXCEPT AS SHOWN)
(RECOMMENDED PCB LAYOUT FOR COM-HPC®)

<p>PROPRIETARY NOTE</p> <p>THIS DOCUMENT CONTAINS CONFIDENTIAL AND PROPRIETARY INFORMATION AND ALL DESIGN, MANUFACTURING, REPRODUCTION, USE, PATENT RIGHTS AND SALES RIGHTS ARE EXPRESSLY RESERVED BY SAMTEC, INC. THIS DOCUMENT SHALL NOT BE DISCLOSED, IN WHOLE OR PART, TO ANY UNAUTHORIZED PERSON OR ENTITY NOR REPRODUCED, TRANSFERRED OR INCORPORATED IN ANY OTHER PROJECT IN ANY MANNER WITHOUT THE EXPRESS WRITTEN CONSENT OF SAMTEC, INC.</p>	 520 PARK EAST BLVD., NEW ALBANY, IN 47150 PHONE: 812-944-6733 FAX: 812-948-5047 e-Mail info@SAMTEC.com code 55322		
	DESCRIPTION: CUSTOM COM HPC FEMALE ASSEMBLY		
	DWG. NO. ASP-209946-02		
SHEET SCALE: 6:1	BY: R. CURRY	11/05/2020	SHEET 5 OF 8

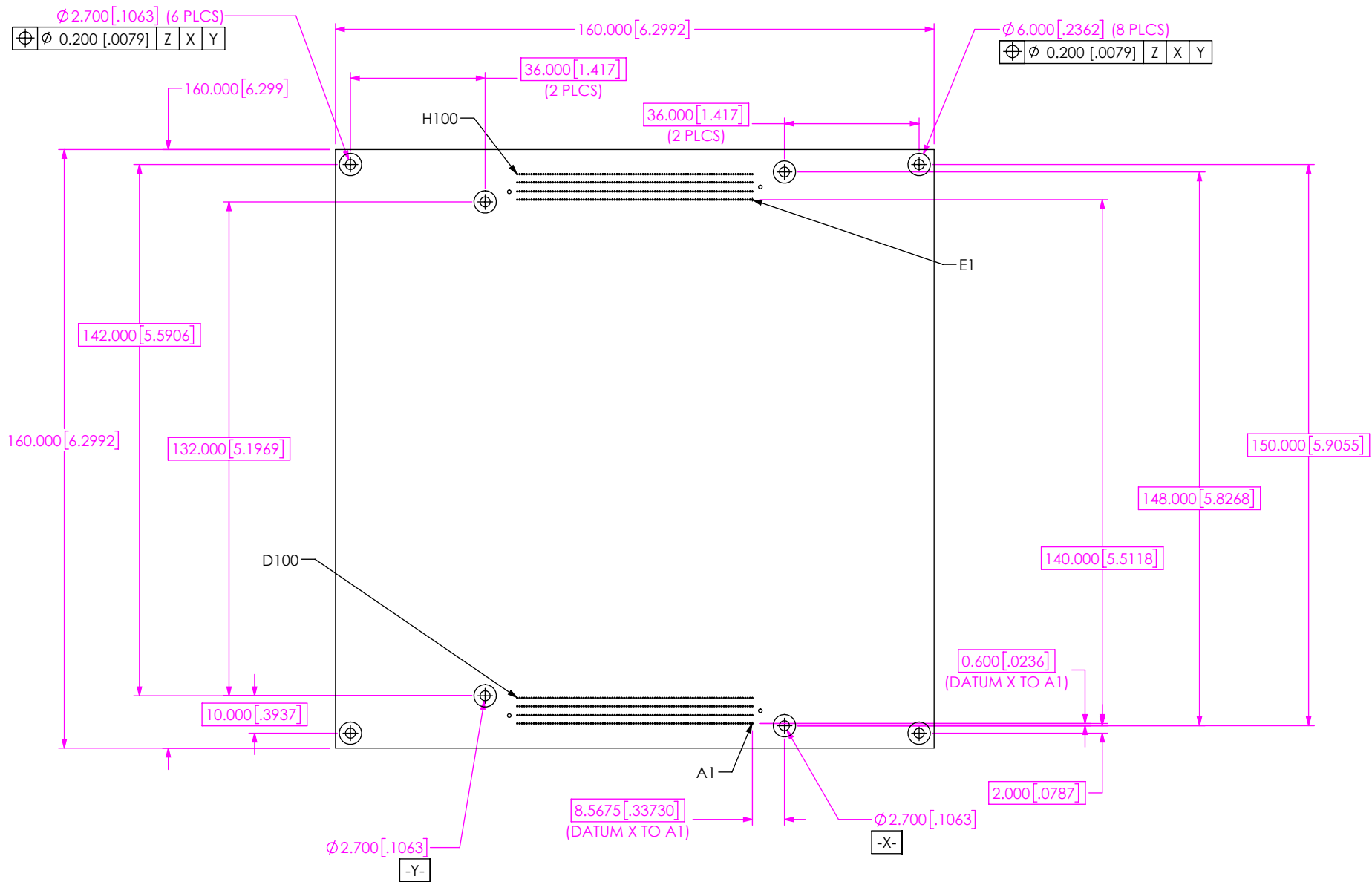

FIG 5
COM-HPC® MODULE SIZE D
(SAME AS FIG 2, EXCEPT AS SHOWN)
(RECOMMENDED PCB LAYOUT FOR COM-HPC®)

<p>PROPRIETARY NOTE</p> <p>THIS DOCUMENT CONTAINS CONFIDENTIAL AND PROPRIETARY INFORMATION AND ALL DESIGN, MANUFACTURING, REPRODUCTION, USE, PATENT RIGHTS AND SALES RIGHTS ARE EXPRESSLY RESERVED BY SAMTEC, INC. THIS DOCUMENT SHALL NOT BE DISCLOSED, IN WHOLE OR PART, TO ANY UNAUTHORIZED PERSON OR ENTITY NOR REPRODUCED, TRANSFERRED OR INCORPORATED IN ANY OTHER PROJECT IN ANY MANNER WITHOUT THE EXPRESS WRITTEN CONSENT OF SAMTEC, INC.</p>	<p>samtec</p> <p>520 PARK EAST BLVD., NEW ALBANY, IN 47150 PHONE: 812-944-6733 FAX: 812-948-5047 e-Mail info@SAMTEC.com code 55322</p>		
	<p>DESCRIPTION: CUSTOM COM HPC FEMALE ASSEMBLY</p>		
	<p>DWG. NO. ASP-209946-02</p>		
<p>SHEET SCALE: 6:1</p>	<p>BY: R. CURRY</p>	<p>11/05/2020</p>	<p>SHEET 6 OF 8</p>

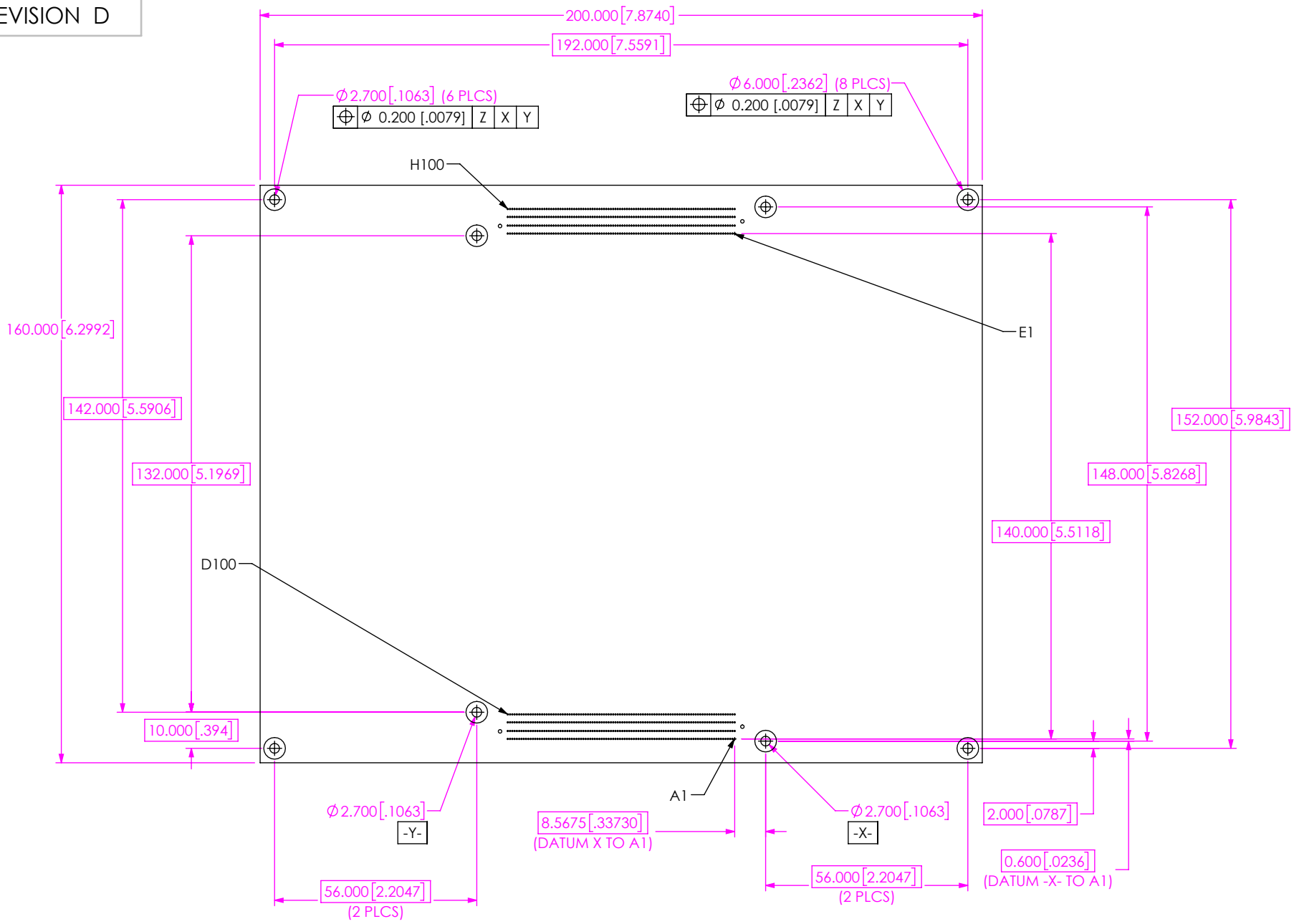

FIG 6
COM-HPC® MODULE SIZE E
 (SAME AS FIG 2, EXCEPT AS SHOWN)
 (RECOMMENDED PCB LAYOUT FOR COM-HPC®)

PROPRIETARY NOTE
 * THIS DOCUMENT CONTAINS CONFIDENTIAL AND PROPRIETARY INFORMATION AND ALL DESIGN, MANUFACTURING, REPRODUCTION, USE, PATENT RIGHTS AND SALES RIGHTS ARE EXPRESSLY RESERVED BY SAMTEC, INC. THIS DOCUMENT SHALL NOT BE DISCLOSED, IN WHOLE OR PART, TO ANY UNAUTHORIZED PERSON OR ENTITY NOR REPRODUCED, TRANSFERRED OR INCORPORATED IN ANY OTHER PROJECT IN ANY MANNER WITHOUT THE EXPRESS WRITTEN CONSENT OF SAMTEC, INC. *

samtec
 520 PARK EAST BLVD, NEW ALBANY, IN 47150
 PHONE: 812-944-6733 FAX: 812-948-5047
 e-Mail info@SAMTEC.com code 55322

SHEET SCALE: 1:1

DESCRIPTION:
 CUSTOM COM HPC FEMALE ASSEMBLY
 DWG. NO.
ASP-209946-02
 BY: R. CURRY 11/05/2020 SHEET 7 OF 8

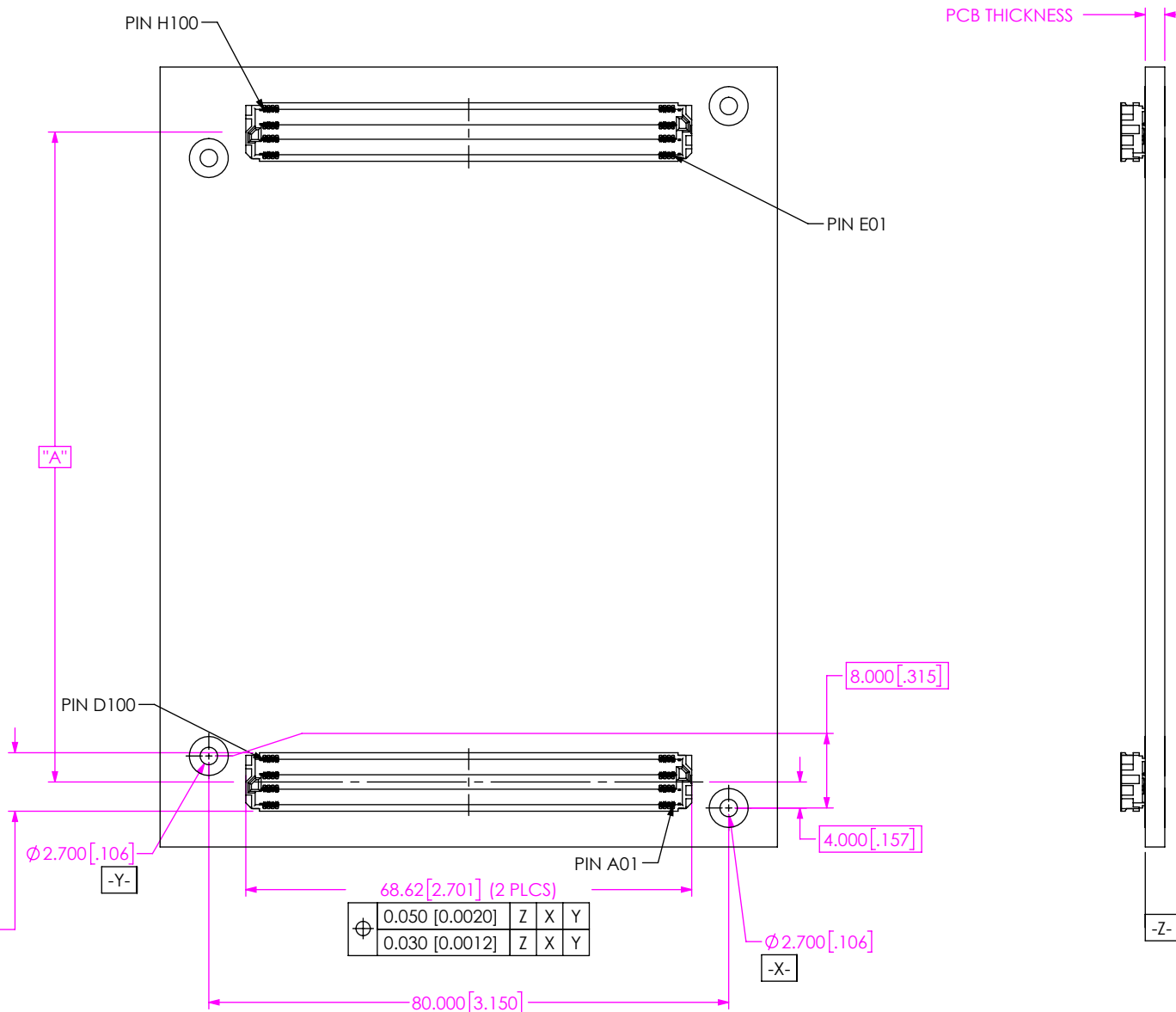

\varnothing	0.050 [0.0020]	Z	X	Y
\varnothing	0.030 [0.0012]	Z	X	Y

\varnothing	0.050 [0.0020]	Z	X	Y
\varnothing	0.030 [0.0012]	Z	X	Y

FIG 7
 COM-HPC® ASSEMBLY APPLICATION
 (RECOMMENDED ASP-209946-02 LAYOUT FOR COM-HPC®)

TABLE 1	
COM-HPC® MODULE	"A"
SIZE A	100.000 [3.937]
SIZE B	100.000 [3.937]
SIZE C	100.000 [3.937]
SIZE D	140.000 [5.512]
SIZE E	140.000 [5.512]

PROPRIETARY NOTE
 THIS DOCUMENT CONTAINS CONFIDENTIAL AND PROPRIETARY INFORMATION AND ALL DESIGN, MANUFACTURING, REPRODUCTION, USE, PATENT RIGHTS AND SALES RIGHTS ARE EXPRESSLY RESERVED BY SAMTEC, INC. THIS DOCUMENT SHALL NOT BE DISCLOSED, IN WHOLE OR PART, TO ANY UNAUTHORIZED PERSON OR ENTITY NOR REPRODUCED, TRANSFERRED OR INCORPORATED IN ANY OTHER PROJECT IN ANY MANNER WITHOUT THE EXPRESS WRITTEN CONSENT OF SAMTEC, INC.

SHEET SCALE: 1:1

samtec
 520 PARK EAST BLVD., NEW ALBANY, IN 47150
 PHONE: 812-944-6733 FAX: 812-948-5047
 e-Mail: info@SAMTEC.com code 55322

DESCRIPTION:
 CUSTOM COM HPC FEMALE ASSEMBLY

DWG. NO.
ASP-209946-02

BY: R. CURRY 11/05/2020 SHEET 8 OF 8