

REVISION D

BY SIGNING THIS DOCUMENT YOU ARE ACCEPTING THE CONDITIONS SET WITHIN. YOUR REQUIREMENTS MUST BE LISTED WITHIN THIS DRAWING. WHERE NO DIRECTION FROM THE CUSTOMER IS IDENTIFIED SAMTEC'S PROCESS REQUIREMENTS WILL BE USED.

DATE: \_\_\_\_\_  
 COMPANY: \_\_\_\_\_  
 CUSTOMER SIGNATURE: \_\_\_\_\_  
 PRINTED NAME: \_\_\_\_\_  
 PHONE No: \_\_\_\_\_  
 EXCEPTIONS: \_\_\_\_\_

- NOTES:
1. MINIMUM PUSHOUT FORCE: 1.2N
  2. PARTS TO BE PACKAGED IN TAPE & REEL.
  3. ATTACH LABEL -4X2 TO EACH REEL.
  4. ORDERS WILL BE PACKAGED ACCORDING TO THE SAMTEC PACKAGING EFFICIENCY STANDARDS (SPES) FOUND ON WWW.SAMTEC.COM.

**DESIGNED & DIMENSIONED IN MILLIMETERS[INCHES]  
 ALL DIMENSIONS REFERENCE EXCEPT AS SHOWN**

DO NOT SCALE FROM THIS PRINT

SOME CENTER FEATURES NOT SHOWN FOR CLARITY

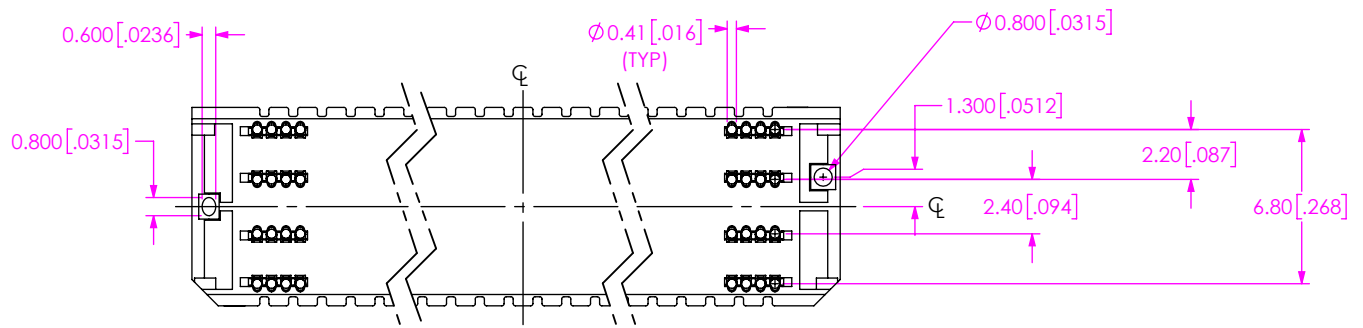
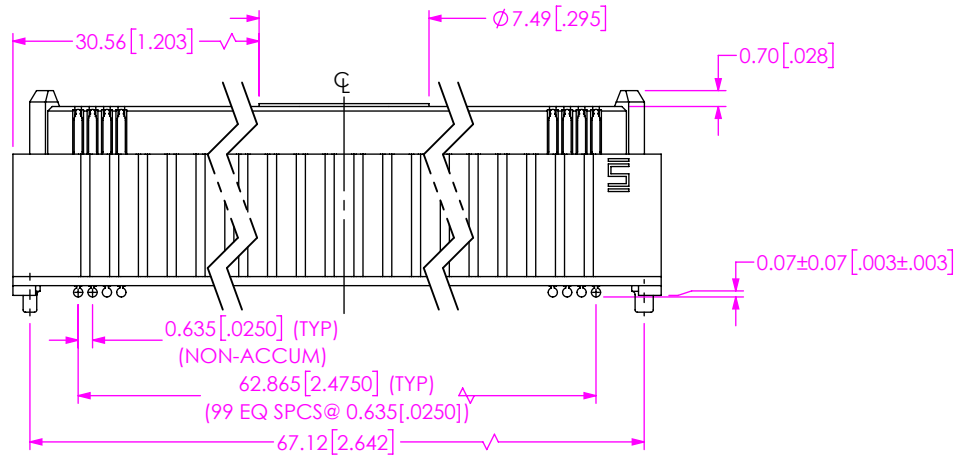
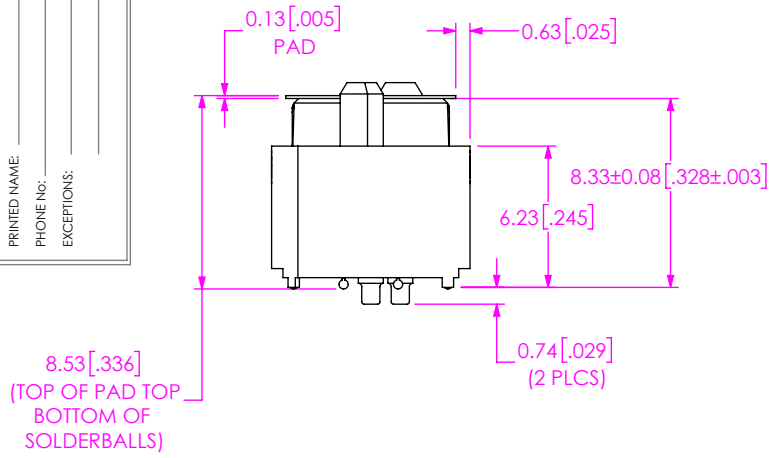
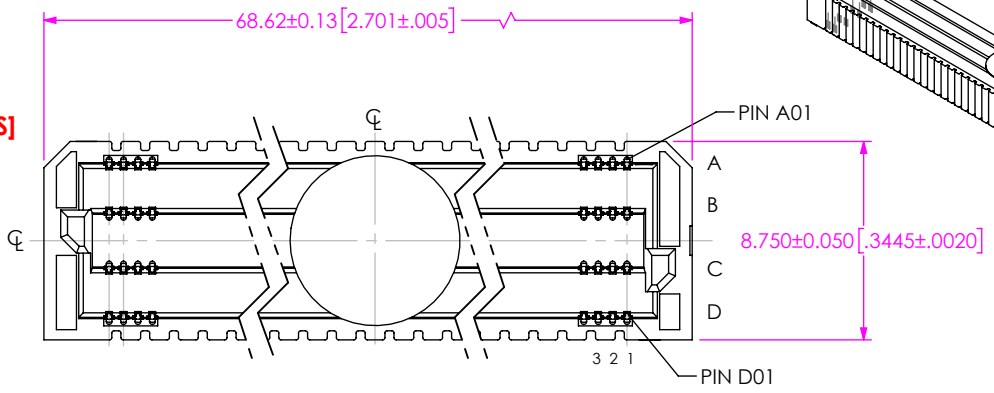
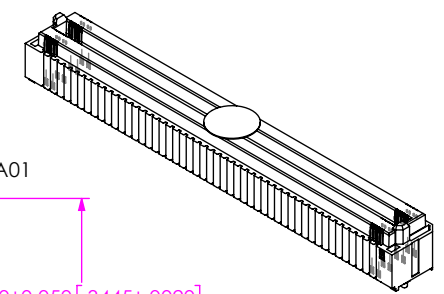
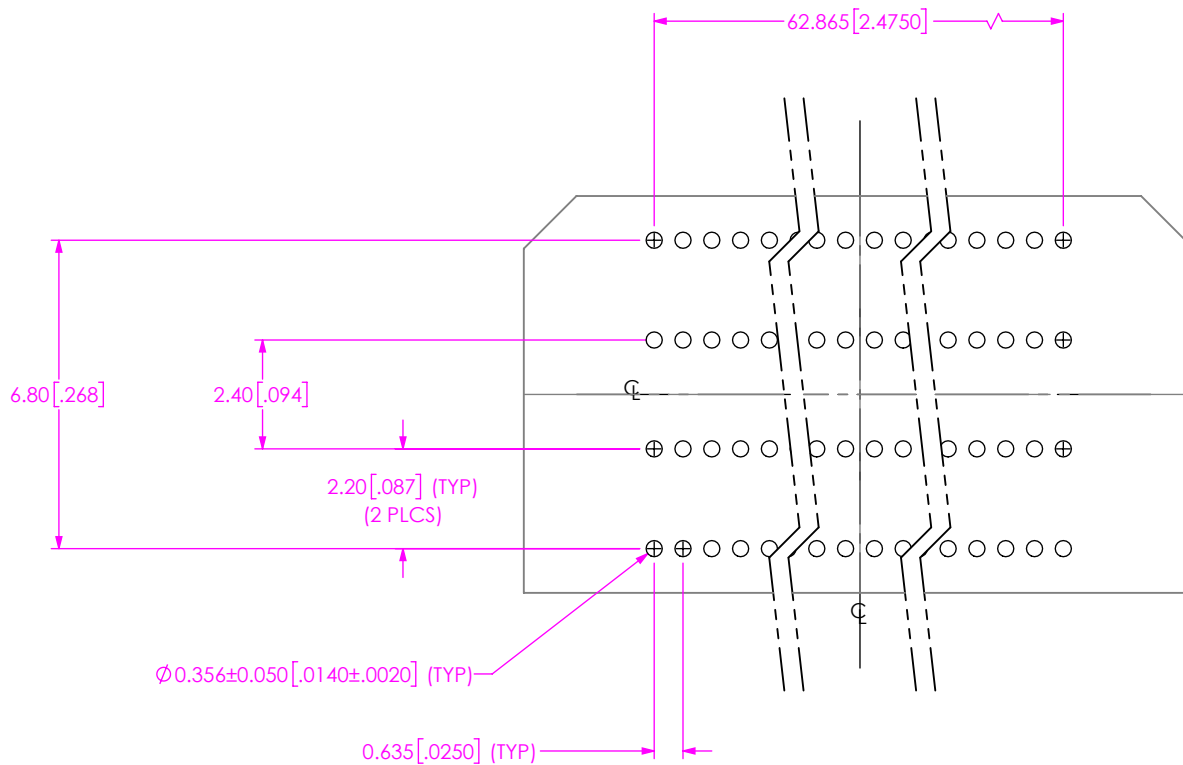

FIG 1  
 (ASP-209948-02 SHOWN)

<p>PROPRIETARY NOTE</p> <p>THIS DOCUMENT CONTAINS CONFIDENTIAL AND PROPRIETARY INFORMATION AND ALL DESIGN, MANUFACTURING, REPRODUCTION, USE, PATENT RIGHTS AND SALES RIGHTS ARE EXPRESSLY RESERVED BY SAMTEC, INC. THIS DOCUMENT SHALL NOT BE DISCLOSED, IN WHOLE OR PART, TO ANY UNAUTHORIZED PERSON OR ENTITY NOR REPRODUCED, TRANSFERRED OR INCORPORATED IN ANY OTHER PROJECT IN ANY MANNER WITHOUT THE EXPRESS WRITTEN CONSENT OF SAMTEC, INC.</p>		<p>520 PARK EAST BLVD, NEW ALBANY, IN 47150                  PHONE: 812-944-6733 FAX: 812-948-5047                  e-Mail info@SAMTEC.com code 53322</p>
<p>DO NOT SCALE DRAWING</p> <p>PLATING:                  CONTACT AREA: .000030" GOLD OVER .000050" NICKEL                  REMAINDER: .000200" REF TIN OVER .000050" NICKEL</p>	<p>SHEET SCALE: 3:1</p> <p>DESCRIPTION:                  CUSTOM COM HPC MALE ASSEMBLY</p> <p>DWG. NO.                  ASP-209948-02</p>	
<p>BY: R. CURRY</p>		<p>11/04/2020</p>
<p>SHEET 1 OF 8</p>		<p>SHEET 1 OF 8</p>



RECOMMENDED STENCIL LAYOUT  
 ALL DIMENSIONS SYMMETRIC ABOUT CENTERLINE  
 (STENCIL TO BE 0.125[.0050] THICK)

PROPRIETARY NOTE

THIS DOCUMENT CONTAINS CONFIDENTIAL AND PROPRIETARY INFORMATION AND ALL DESIGN, MANUFACTURING, REPRODUCTION, USE, PATENT RIGHTS AND SALES RIGHTS ARE EXPRESSLY RESERVED BY SAMTEC, INC. THIS DOCUMENT SHALL NOT BE DISCLOSED, IN WHOLE OR PART, TO ANY UNAUTHORIZED PERSON OR ENTITY NOR REPRODUCED, TRANSFERRED OR INCORPORATED IN ANY OTHER PROJECT IN ANY MANNER WITHOUT THE EXPRESS WRITTEN CONSENT OF SAMTEC, INC.



520 PARK EAST BLVD, NEW ALBANY, IN 47150  
 PHONE: 812-944-6733 FAX: 812-948-5047  
 e-Mail info@SAMTEC.com code 55322

SHEET SCALE: 1:1

DESCRIPTION:  
 CUSTOM COM HPC MALE ASSEMBLY

DWG. NO.  
 ASP-209948-02

BY: R. CURRY 11/04/2020 SHEET 2 OF 8



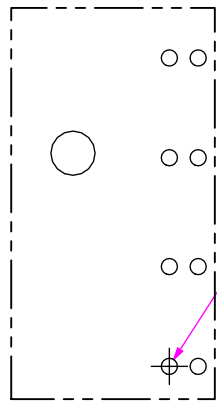

$\phi 0.356 \pm 0.030 [0.140 \pm 0.012]$

$\phi$	$\phi 0.100$	[.0039]	Z	U	V
$\phi$	$\phi 0.200$	[.0079]	Z	S	
-T-					

DETAIL 'D'  
SCALE 6 : 1

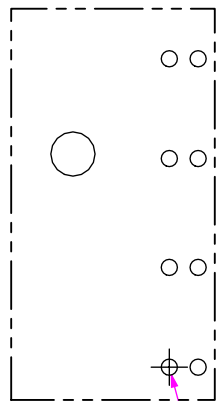
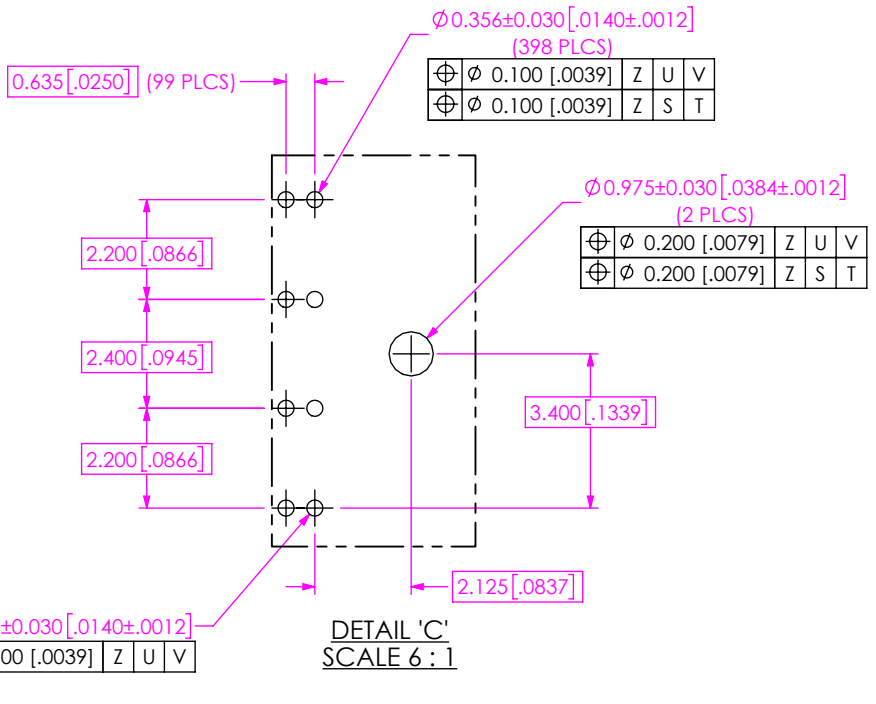

$\phi 0.356 \pm 0.030 [0.140 \pm 0.012]$

$\phi$	$\phi 0.200$	[.0079]	Z	X	Y
$\phi$	$\phi 0.100$	[.0039]	Z	U	
-V-					

DETAIL 'B'  
SCALE 6 : 1

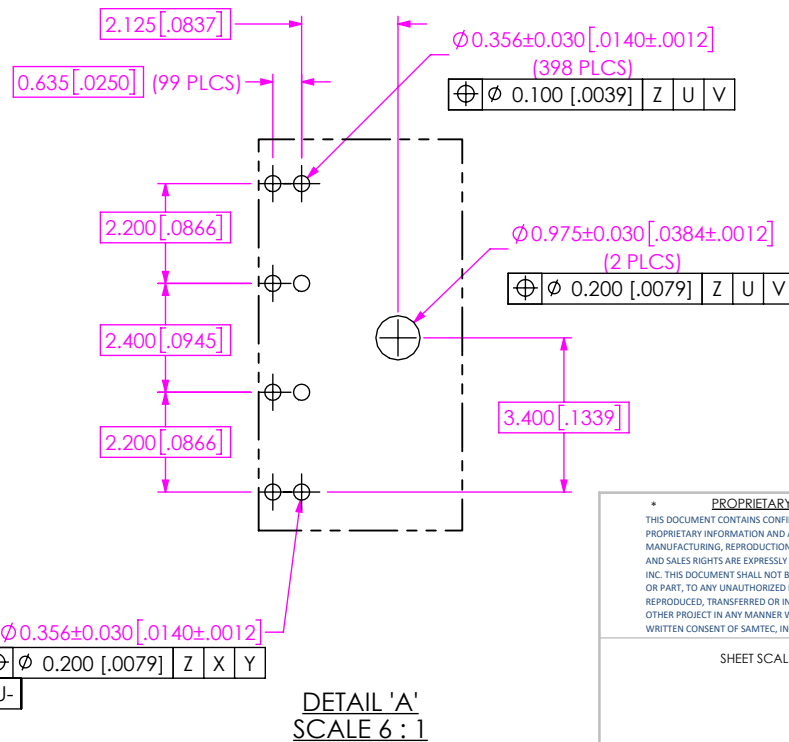

**PROPRIETARY NOTE**

THIS DOCUMENT CONTAINS CONFIDENTIAL AND PROPRIETARY INFORMATION AND ALL DESIGN, MANUFACTURING, REPRODUCTION, USE, PATENT RIGHTS AND SALES RIGHTS ARE EXPRESSLY RESERVED BY SAMTEC, INC. THIS DOCUMENT SHALL NOT BE DISCLOSED, IN WHOLE OR PART, TO ANY UNAUTHORIZED PERSON OR ENTITY NOR REPRODUCED, TRANSFERRED OR INCORPORATED IN ANY OTHER PROJECT IN ANY MANNER WITHOUT THE EXPRESS WRITTEN CONSENT OF SAMTEC, INC.

SHEET SCALE: 1:2



520 PARK EAST BLVD, NEW ALBANY, IN 47150  
PHONE: 812-944-6733 FAX: 812-948-5047  
e-Mail info@SAMTEC.com code 55322

DESCRIPTION:  
CUSTOM COM HPC MALE ASSEMBLY

DWG. NO.  
**ASP-209948-02**

BY: R. CURRY 11/04/2020 SHEET 4 OF 8

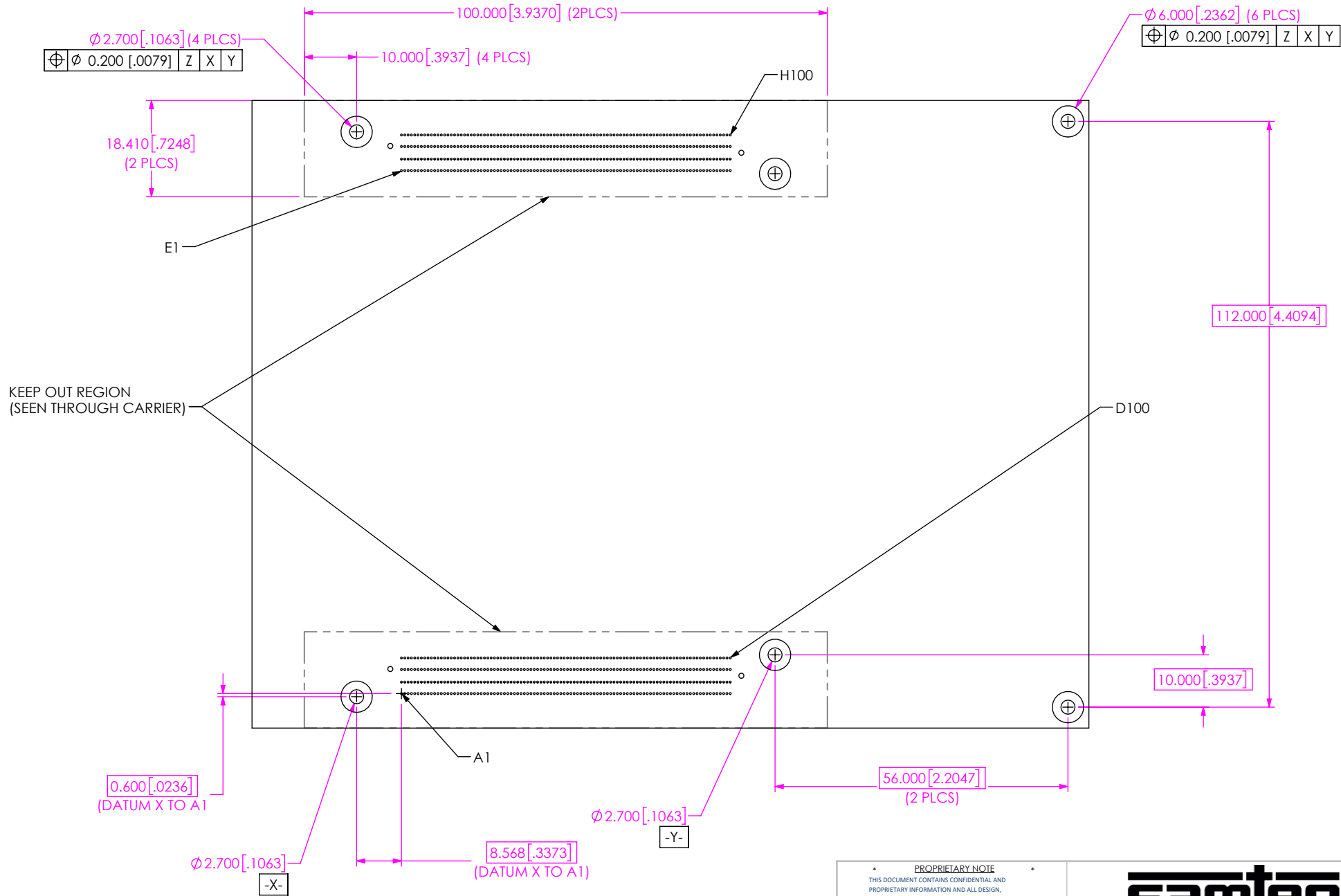

**FIG 3**  
 (RECOMMENDED ASP-209948-02)  
 (SAME AS FIG 2, EXCEPT AS SHOWN)  
 (LAYOUT FOR COM-HPC® MODULE SIZE C)

<p><b>PROPRIETARY NOTE</b></p> <p>THIS DOCUMENT CONTAINS CONFIDENTIAL AND PROPRIETARY INFORMATION AND ALL DESIGN, MANUFACTURING, REPRODUCTION, USE, PATENT RIGHTS AND SALES RIGHTS ARE EXPRESSLY RESERVED BY SAMTEC, INC. THIS DOCUMENT SHALL NOT BE DISCLOSED, IN WHOLE OR PART, TO ANY UNAUTHORIZED PERSON OR ENTITY NOR REPRODUCED, TRANSFERRED OR INCORPORATED IN ANY OTHER PROJECT IN ANY MANNER WITHOUT THE EXPRESS WRITTEN CONSENT OF SAMTEC, INC.</p>	<p><b>samtec</b></p> <p>520 PARK EAST BLVD, NEW ALBANY, IN 47150                  PHONE: 812-944-6733 FAX: 812-948-5047                  e-Mail info@SAMTEC.com code 55322</p>		
	<p>DESCRIPTION:                  CUSTOM COM HPC MALE ASSEMBLY</p>		
	<p>DWG. NO.                  ASP-209948-02</p>		
<p>SHEET SCALE: 1:2</p>	<p>BY: R. CURRY</p>	<p>11/04/2020</p>	<p>SHEET 5 OF 8</p>





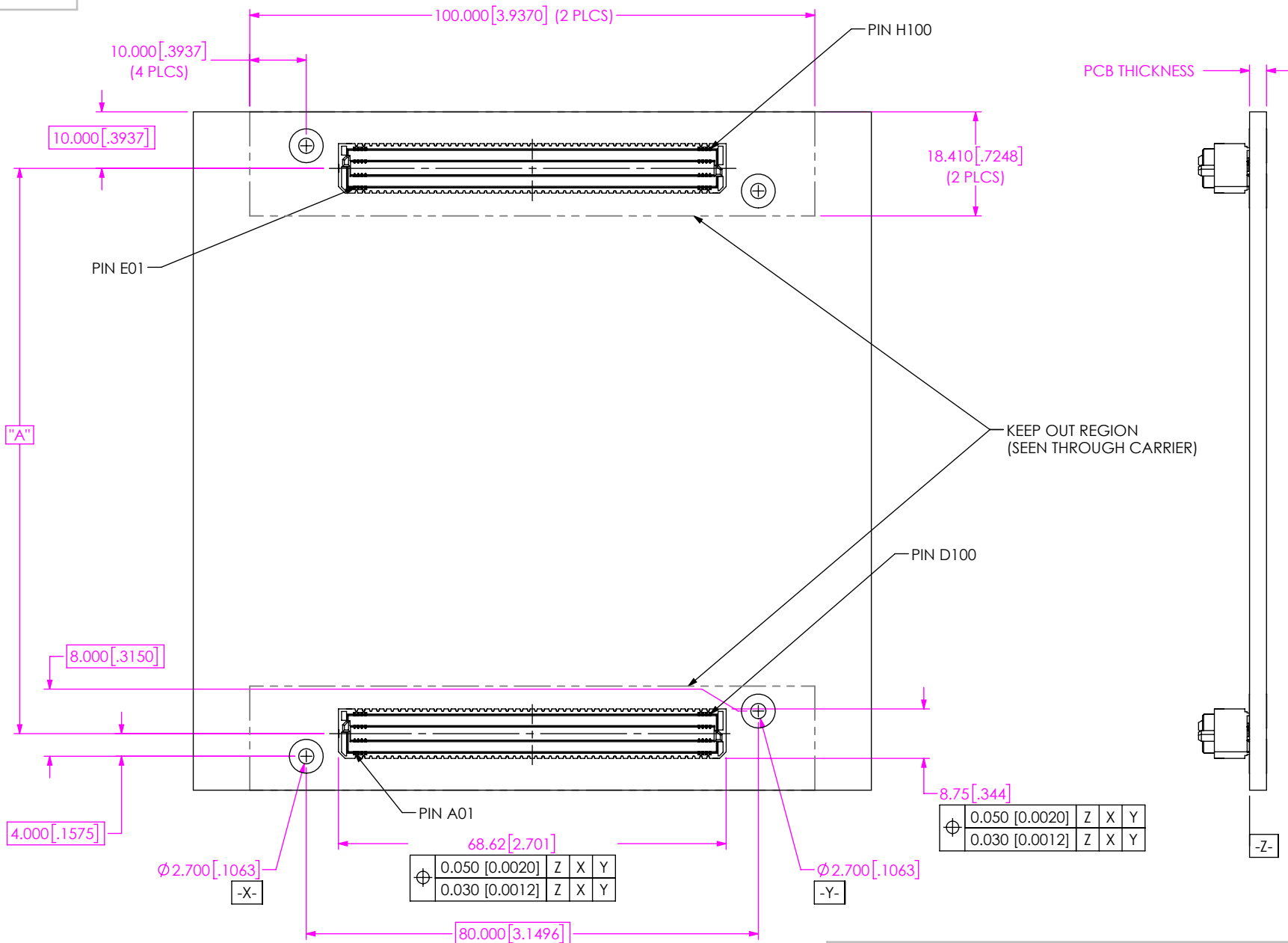

FIG 6  
COM-HPC® ASSEMBLY APPLICATION  
(RECOMMENDED ASP-209948-02 LAYOUT FOR COM-HPC®)

TABLE 1	
COM-HPC® MODULE	"A"
SIZE A	100.000 [3.937]
SIZE B	100.000 [3.937]
SIZE C	100.000 [3.937]
SIZE D	140.000 [5.512]
SIZE E	140.000 [5.512]

**PROPRIETARY NOTE**

THIS DOCUMENT CONTAINS CONFIDENTIAL AND PROPRIETARY INFORMATION AND ALL DESIGN, MANUFACTURING, REPRODUCTION, USE, PATENT RIGHTS AND SALES RIGHTS ARE EXPRESSLY RESERVED BY SAMTEC, INC. THIS DOCUMENT SHALL NOT BE DISCLOSED, IN WHOLE OR PART, TO ANY UNAUTHORIZED PERSON OR ENTITY NOR REPRODUCED, TRANSFERRED OR INCORPORATED IN ANY OTHER PROJECT IN ANY MANNER WITHOUT THE EXPRESS WRITTEN CONSENT OF SAMTEC, INC.

SHEET SCALE: 1:2

**samtec**

520 PARK EAST BLVD. NEW ALBANY, IN 47150  
PHONE: 812-944-6733 FAX: 812-948-5047  
e-Mail info@SAMTEC.com code 55322

DESCRIPTION:  
CUSTOM COM HPC MALE ASSEMBLY

DWG. NO.  
**ASP-209948-02**

BY: R. CURRY 11/04/2020 SHEET 8 OF 8