

DO NOT SCALE FROM THIS PRINT

NOTES:

1. CUSTOM BODY IS NOT AVAILABLE AS STANDARD.
2. MINIMUM PUSHOUT FORCE: .50 LBS
3. PARTS TO BE PACKAGED IN TAPE & REEL.  
ATTACH LABEL "SEAX-0001" TO EACH TAPE & REEL PACKAGING.
4. ORDERS WILL BE PACKAGED ACCORDING TO THE SAMTEC PACKAGING EFFICIENCY STANDARDS (SPES) FOUND ON WWW.SAMTEC.COM.
5. ATTACH LABEL -4X2 TO EACH REEL.

DESIGNED AND DIMENSIONED IN INCHES[MILLIMETERS]  
ALL DIMENSIONS REFERENCE EXCEPT AS SHOWN

**PF** THIS PRODUCT MANUFACTURED WITH LEAD-FREE PROCESSING

BY SIGNING THIS DOCUMENT YOU ARE ACCEPTING THE CONDITIONS SET WITHIN. YOUR REQUIREMENTS MUST BE LISTED WITHIN THIS DRAWING. WHERE NO DIRECTION FROM THE CUSTOMER IS IDENTIFIED SAMTEC'S PROCESS REQUIREMENTS WILL BE USED.

DATE: \_\_\_\_\_  
 COMPANY: \_\_\_\_\_  
 CUSTOMER SIGNATURE: \_\_\_\_\_  
 PRINTED NAME: \_\_\_\_\_  
 PHONE No.: \_\_\_\_\_  
 EXCEPTIONS: \_\_\_\_\_

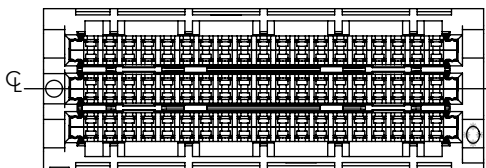
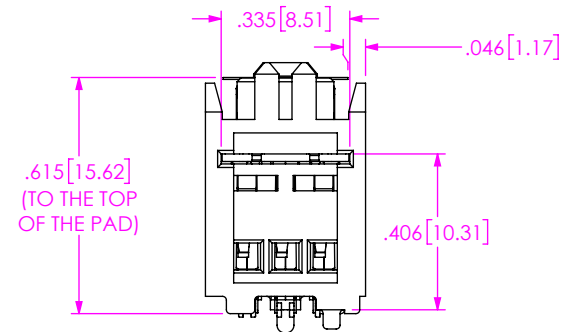
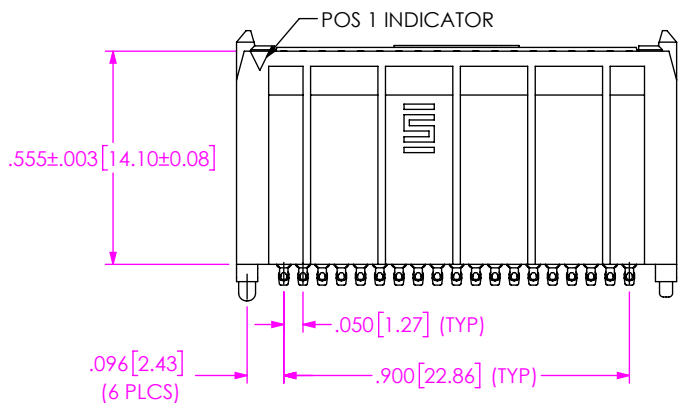
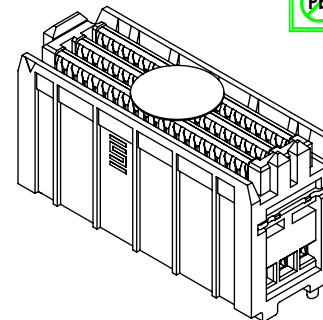
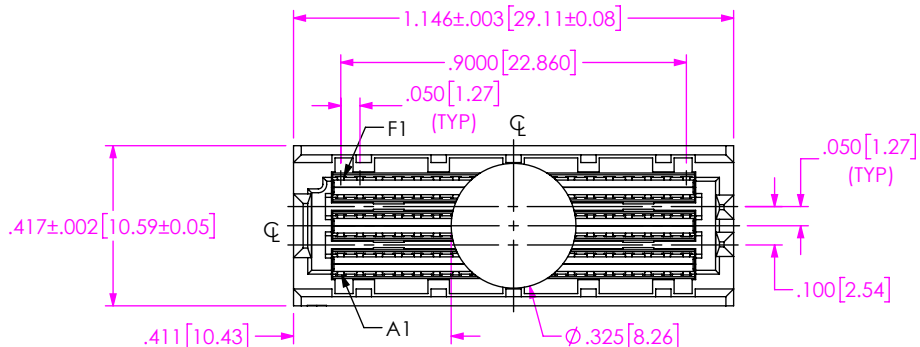

<p><b>PROPRIETARY NOTE</b></p> <p>THIS DOCUMENT CONTAINS CONFIDENTIAL AND PROPRIETARY INFORMATION AND ALL DESIGN, MANUFACTURING, REPRODUCTION, USE, PATENT RIGHTS AND SALES RIGHTS ARE EXPRESSLY RESERVED BY SAMTEC, INC. THIS DOCUMENT SHALL NOT BE DISCLOSED, IN WHOLE OR PART, TO ANY UNAUTHORIZED PERSON OR ENTITY NOR REPRODUCED, TRANSFERRED OR INCORPORATED IN ANY OTHER PROJECT IN ANY MANNER WITHOUT THE EXPRESS WRITTEN CONSENT OF SAMTEC, INC.</p>		 <p>520 PARK EAST BLVD, NEW ALBANY, IN 47150                  PHONE: 812-944-6733 FAX: 812-948-5047                  e-Mail: info@SAMTEC.com code 55322</p>	
<p>DO NOT SCALE DRAWING SHEET SCALE: 2:1</p>		<p>DESCRIPTION: VITA88 MODIFIED SEAM ASM</p>	
<p>MATERIAL:                  INSULATOR: LCP, COLOR: BLACK, UL 94 V-0                  TERMINAL: COPPER ALLOY                  PLATING:                  CONTACT AREA: .00020 GOLD OVER .00050 NICKEL                  REMAINDER: .000200 REF TIN OVER .00050 NICKEL                  SOLDER COMPOSITION: 95.5% TIN / 3.8% SILVER / 0.7% COPPER CHARGE TAIL</p>		<p>DWG. NO. ASP-212956-02</p>	
<p>BY: ANN H</p>		<p>3/29/2023 SHEET 1 OF 2</p>	

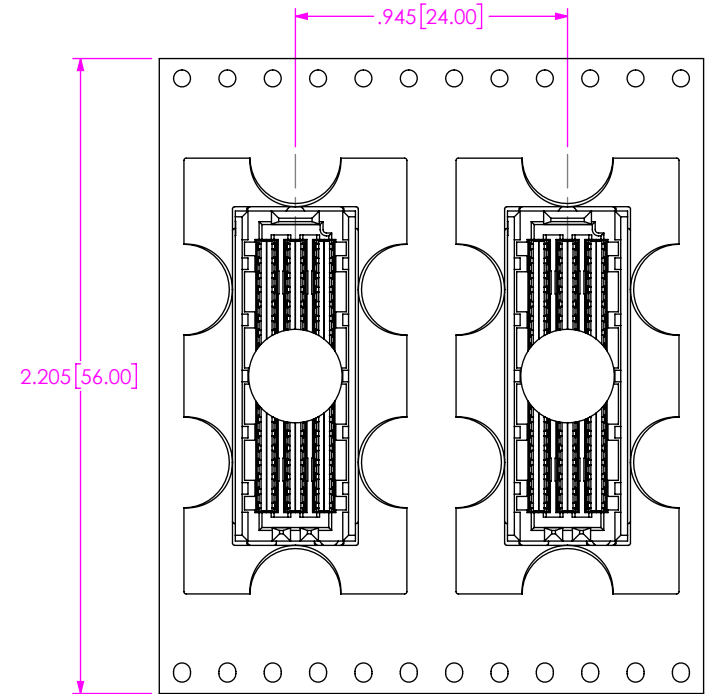
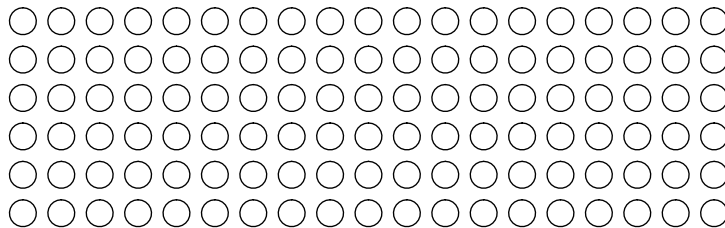
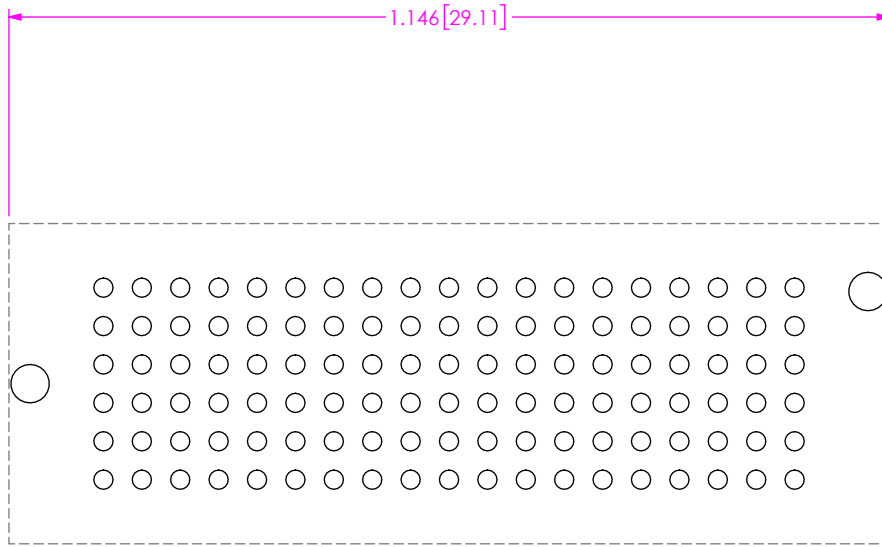

USER DIRECTION OF UN-REELING →  
POCKET NOT DETAILED

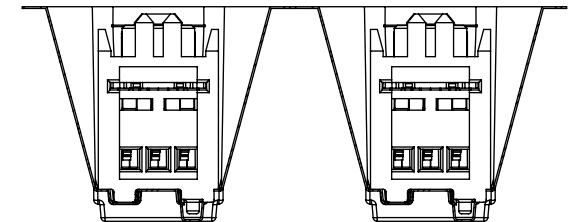

PACKAGING VIEW

**PROPRIETARY NOTE**  
THIS DOCUMENT CONTAINS CONFIDENTIAL AND PROPRIETARY INFORMATION AND ALL DESIGN, MANUFACTURING, REPRODUCTION, USE, PATENT RIGHTS AND SALES RIGHTS ARE EXPRESSLY RESERVED BY SAMTEC, INC. THIS DOCUMENT SHALL NOT BE DISCLOSED, IN WHOLE OR PART, TO ANY UNAUTHORIZED PERSON OR ENTITY NOR REPRODUCED, TRANSFERRED OR INCORPORATED IN ANY OTHER PROJECT IN ANY MANNER WITHOUT THE EXPRESS WRITTEN CONSENT OF SAMTEC, INC.



520 PARK EAST BLVD, NEW ALBANY, IN 47150  
PHONE: 812-944-6733 FAX: 812-948-5047  
e-Mail: info@SAMTEC.com code 55322

SHEET SCALE: 2:1  
DO NOT SCALE DRAWING

DESCRIPTION: VITA88 MODIFIED SEAM ASM

DWG. NO. ASP-212956-02

BY: ANN H 3/29/2023 SHEET 2 OF 2