

DO NOT SCALE FROM THIS PRINT

NOTES:

1. MINIMUM PUSHOUT FORCE: 1.2N
2. PARTS TO BE PACKAGED IN TAPE & REEL.
3. SHEET 2 FOR PROCESSING INFORMATION.
4. ORDERS WILL BE PACKAGED ACCORDING TO THE SAMTEC PACKAGING EFFICIENCY STANDARDS [SPES] FOUND ON WWW.SAMTEC.COM.
5. ATTACH LABEL-4X2 TO EACH REEL.

DESIGNED AND DIMENSIONED IN MILLIMETERS [INCHES]  
ALL DIMENSIONS REFERENCE EXCEPT AS SHOWN

SOME CENTER FEATURES NOT SHOWN FOR CLARITY

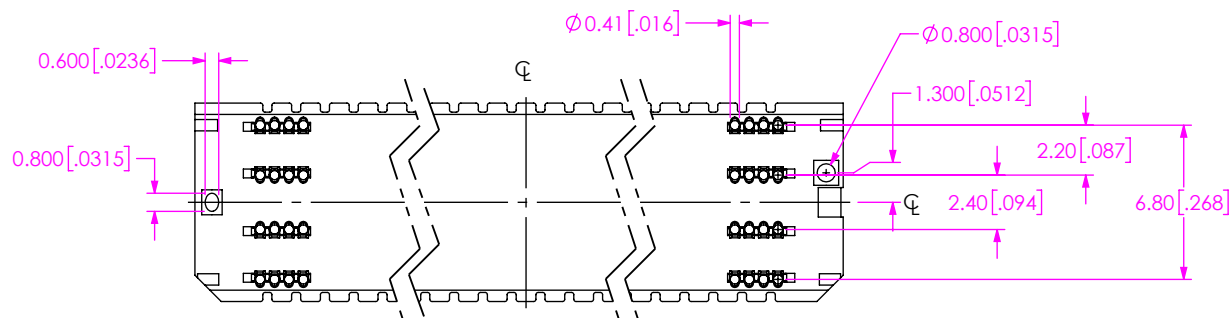
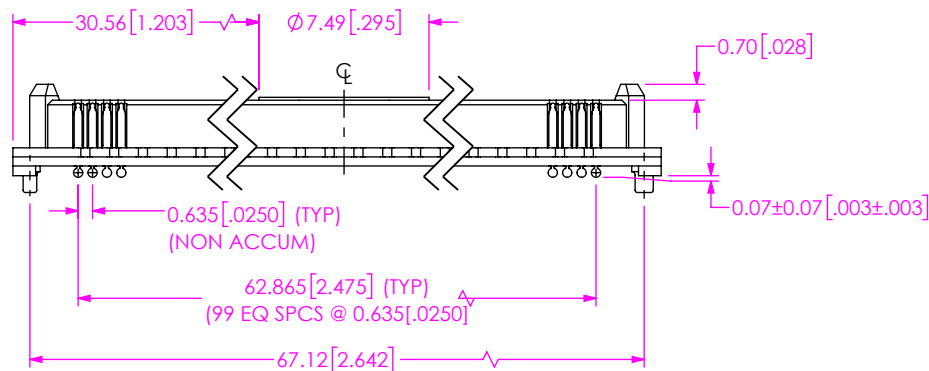
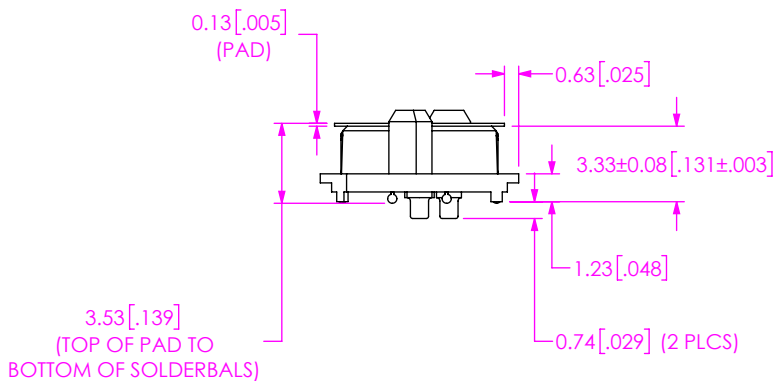
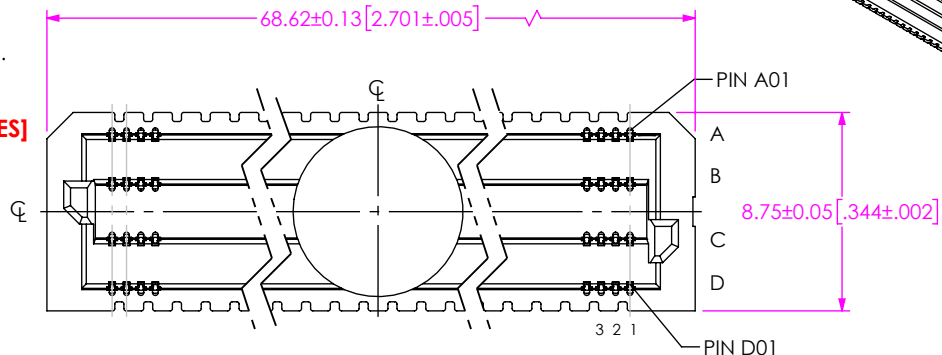
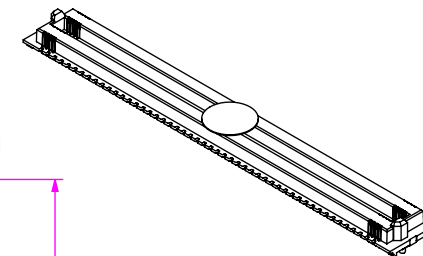
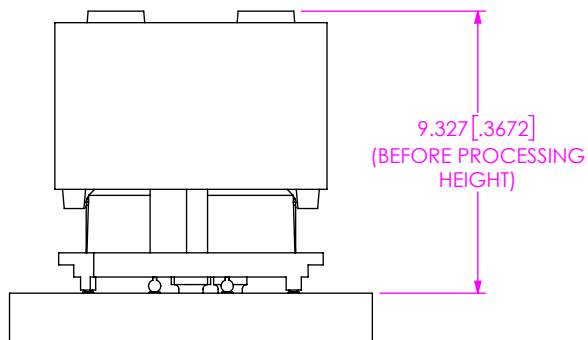
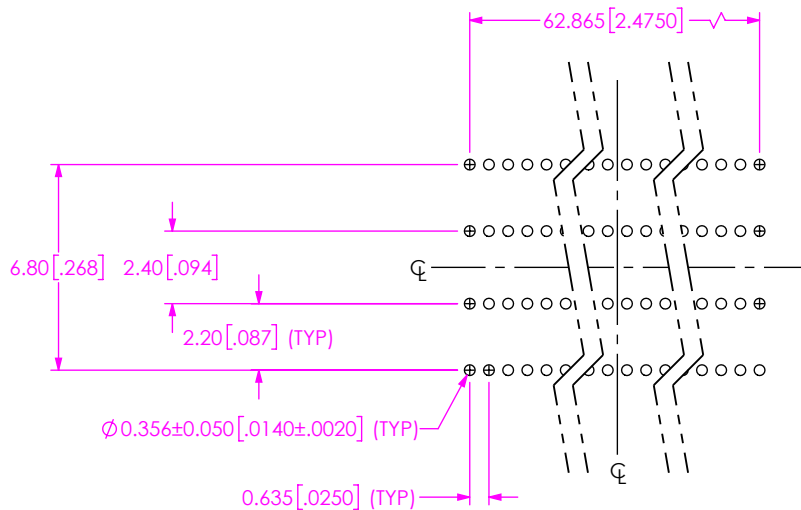

FIG 1  
(ASP-214802-02 SHOWN)

<p><b>PROPRIETARY NOTE</b></p> <p>THIS DOCUMENT CONTAINS CONFIDENTIAL AND PROPRIETARY INFORMATION AND ALL DESIGN, MANUFACTURING, REPRODUCTION, USE, PATENT RIGHTS AND SALES RIGHTS ARE EXPRESSLY RESERVED BY SAMTEC, INC. THIS DOCUMENT SHALL NOT BE DISCLOSED, IN WHOLE OR PART, TO ANY UNAUTHORIZED PERSON OR ENTITY NOR REPRODUCED, TRANSFERRED OR INCORPORATED IN ANY OTHER PROJECT IN ANY MANNER WITHOUT THE EXPRESS WRITTEN CONSENT OF SAMTEC, INC.</p>		<p>520 PARK EAST BLVD, NEW ALBANY, IN 47150 PHONE: 812-944-6733 FAX: 812-948-5047 e-Mail: info@SAMTEC.com code 53322</p>	
DO NOT SCALE DRAWING	SHEET SCALE: 3:1	DESCRIPTION: CUSTOM COM HPC MALE ASSEMBLY	
<p>MATERIAL: INSULATOR: LCP, COLOR: NATURAL TERMINAL: COPPER ALLOY PLATING: CONTACT AREA: .000030" GOLD OVER .000050" NICKEL REMAINDER: .000200" REF TIN OVER .000050" NICKEL</p>		DWG. NO. ASP-214802-02	
F:\DWG\SW\ASP\214000\ASP-214802-02.SLDDRW		BY: R. CURRY	11/05/2020 SHEET 1 OF 8



**PROCESSING VIEW**  
 DIMENSION INDICATES CONNECTOR/FIXTURE HEIGHT ON PCB  
 TO GUARANTEE ENOUGH REFLOW OVEN WORKING SPACE.  
 DIMENSION, PCB THICKNESS, AND THE HEIGHT OF THE COMPONENTS  
 ON THE OTHER SIDE OF THE BOARD NEED TO BE CONSIDERED.



**RECOMMENDED STENCIL LAYOUT**  
 ALL DIMENSIONS SYMMETRIC ABOUT CENTERLINE  
 (STENCIL TO BE 0.125[.0050] THICK)

**PROPRIETARY NOTE**  
 \* THIS DOCUMENT CONTAINS CONFIDENTIAL AND PROPRIETARY INFORMATION AND ALL DESIGN, MANUFACTURING, REPRODUCTION, USE, PATENT RIGHTS AND SALES RIGHTS ARE EXPRESSLY RESERVED BY SAMTEC, INC. THIS DOCUMENT SHALL NOT BE DISCLOSED, IN WHOLE OR PART, TO ANY UNAUTHORIZED PERSON OR ENTITY NOR REPRODUCED, TRANSFERRED OR INCORPORATED IN ANY OTHER PROJECT IN ANY MANNER WITHOUT THE EXPRESS WRITTEN CONSENT OF SAMTEC, INC. \*



520 PARK EAST BLVD., NEW ALBANY, IN 47150  
 PHONE: 812-944-6733 FAX: 812-948-5047  
 e-Mail: info@SAMTEC.com code 55322

SHEET SCALE: 1:1

DESCRIPTION:  
 CUSTOM COM HPC MALE ASSEMBLY

DWG. NO.  
 ASP-214802-02

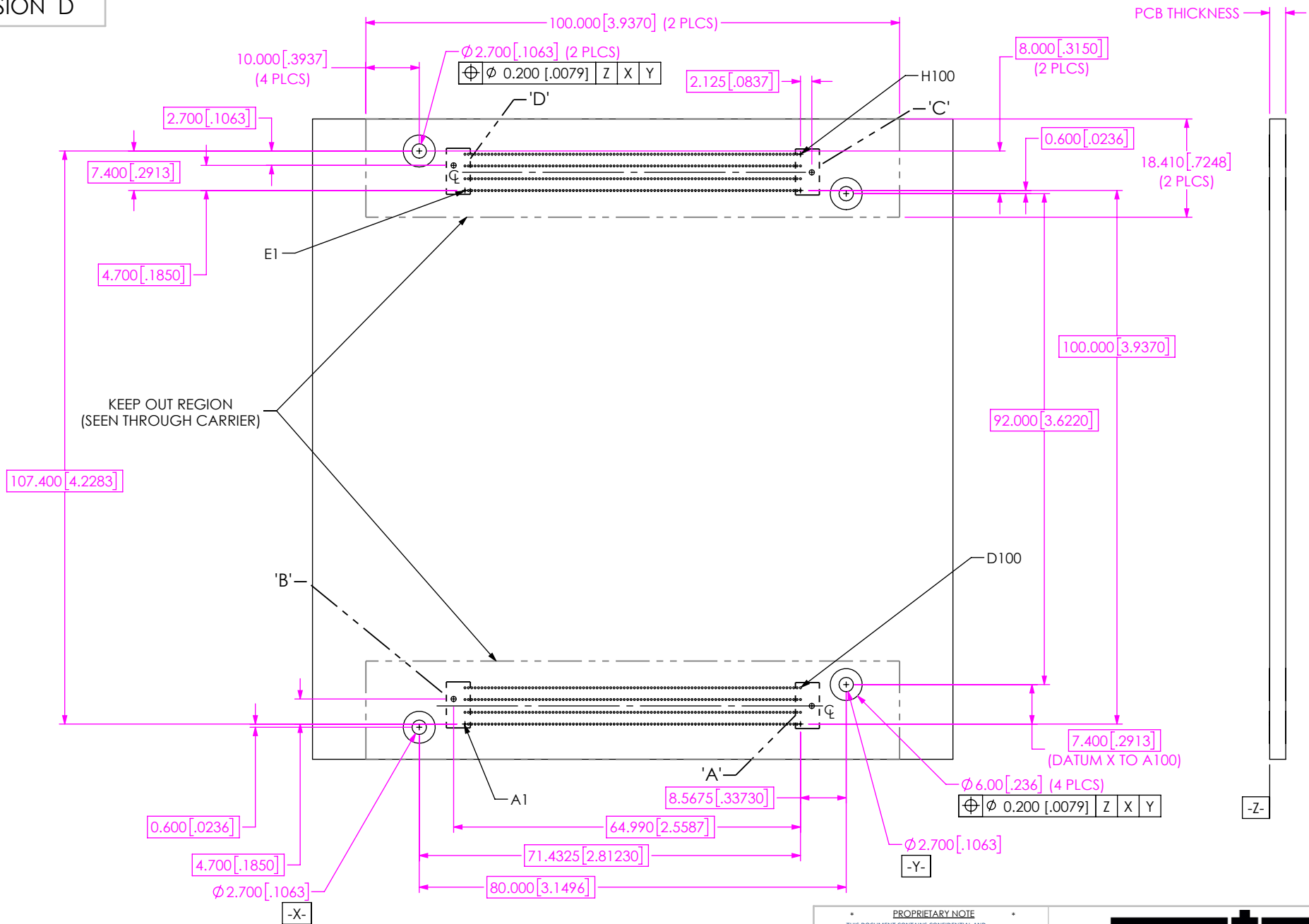

**FIG 2**  
 (RECOMMENDED ASP-214802-02)  
 (LAYOUT FOR COM-HPC® MODULE SIZE A & B)

**PROPRIETARY NOTE**  
 THIS DOCUMENT CONTAINS CONFIDENTIAL AND PROPRIETARY INFORMATION AND ALL DESIGN, MANUFACTURING, REPRODUCTION, USE, PATENT RIGHTS AND SALES RIGHTS ARE EXPRESSLY RESERVED BY SAMTEC, INC. THIS DOCUMENT SHALL NOT BE DISCLOSED, IN WHOLE OR PART, TO ANY UNAUTHORIZED PERSON OR ENTITY NOR REPRODUCED, TRANSFERRED OR INCORPORATED IN ANY OTHER PROJECT IN ANY MANNER WITHOUT THE EXPRESS WRITTEN CONSENT OF SAMTEC, INC.

SHEET SCALE: 1:1

F:\DWG\SW\ASP\214000\ASP-214802-02.SLDDRW

**samtec**  
 520 PARK EAST BLVD, NEW ALBANY, IN 47150  
 PHONE: 812-944-6733 FAX: 812-948-5047  
 e-Mail info@SAMTEC.com code 55322

DESCRIPTION:  
 CUSTOM COM HPC MALE ASSEMBLY

DWG. NO.  
**ASP-214802-02**

BY: R. CURRY 11/05/2020 SHEET 3 OF 8

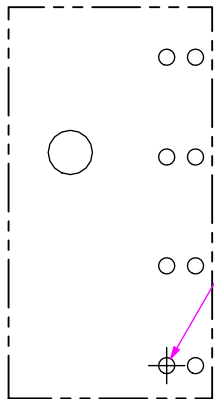

$\phi 0.356 \pm 0.030 [0.140 \pm 0.012]$

$\phi$	0.100	[.0039]	Z	U	V
$\phi$	0.200	[.0079]	Z	S	
-T-					

DETAIL 'D'  
SCALE 6 : 1

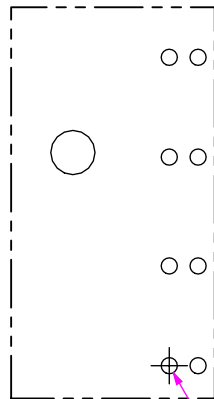

$\phi 0.356 \pm 0.030 [0.140 \pm 0.012]$

$\phi$	0.200	[.0079]	Z	X	Y
$\phi$	0.100	[.0039]	Z	U	
-V-					

DETAIL 'B'  
SCALE 6 : 1

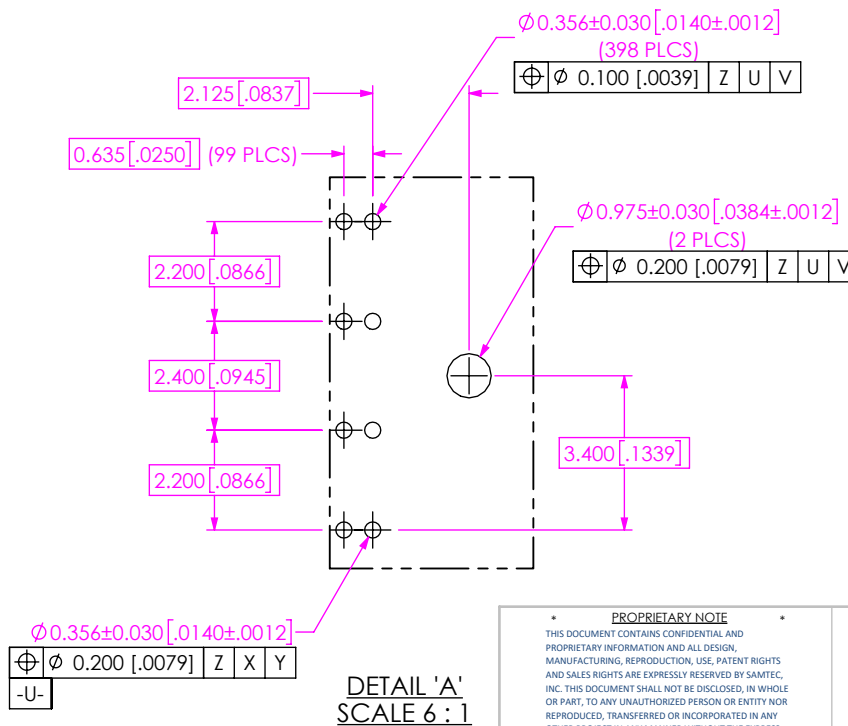
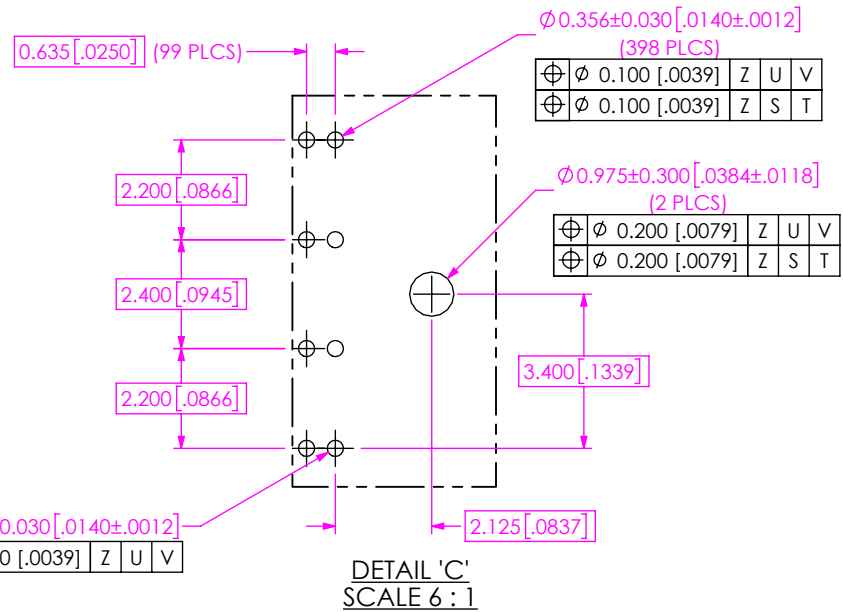

**PROPRIETARY NOTE**

THIS DOCUMENT CONTAINS CONFIDENTIAL AND PROPRIETARY INFORMATION AND ALL DESIGN, MANUFACTURING, REPRODUCTION, USE, PATENT RIGHTS AND SALES RIGHTS ARE EXPRESSLY RESERVED BY SAMTEC, INC. THIS DOCUMENT SHALL NOT BE DISCLOSED, IN WHOLE OR PART, TO ANY UNAUTHORIZED PERSON OR ENTITY NOR REPRODUCED, TRANSFERRED OR INCORPORATED IN ANY OTHER PROJECT IN ANY MANNER WITHOUT THE EXPRESS WRITTEN CONSENT OF SAMTEC, INC.

SHEET SCALE: 1:1

F:\DWG\SW\ASP\214000\ASP-214802-02.SLDDRW

**samtec**

520 PARK EAST BLVD, NEW ALBANY, IN 47150  
 PHONE: 812-944-6733 FAX: 812-948-5047  
 e-Mail info@SAMTEC.com code 55322

DESCRIPTION:  
 CUSTOM COM HPC MALE ASSEMBLY

DWG. NO.  
**ASP-214802-02**

BY: R. CURRY 11/05/2020 SHEET 4 OF 8

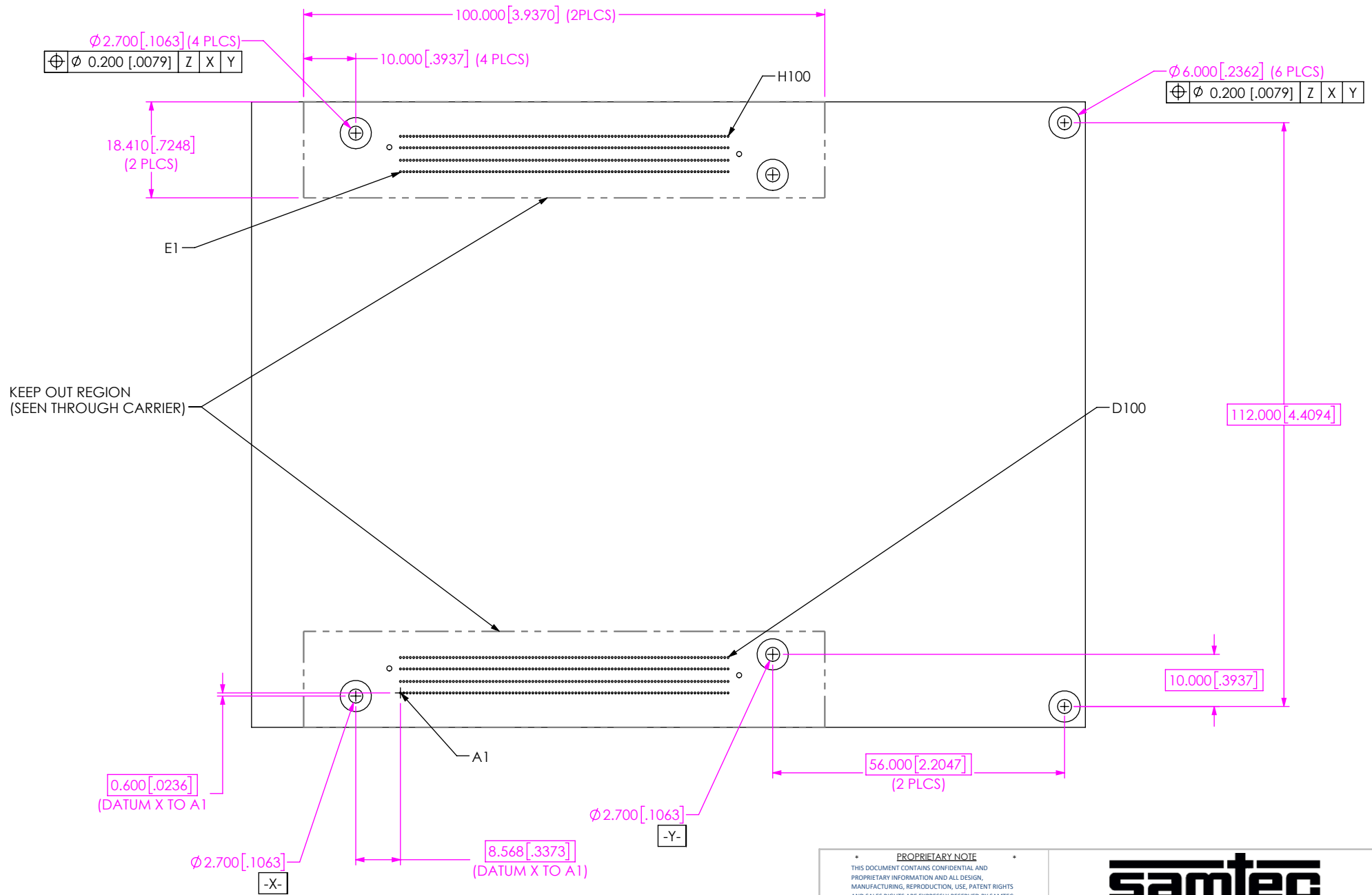

**FIG 3**  
 (RECOMMENDED ASP-214802-02)  
 (SAME AS FIG 2, EXCEPT AS SHOWN)  
 (LAYOUT FOR COM-HPC<sup>®</sup> MODULE SIZE C)

<p><b>PROPRIETARY NOTE</b></p> <p>THIS DOCUMENT CONTAINS CONFIDENTIAL AND PROPRIETARY INFORMATION AND ALL DESIGN, MANUFACTURING, REPRODUCTION, USE, PATENT RIGHTS AND SALES RIGHTS ARE EXPRESSLY RESERVED BY SAMTEC, INC. THIS DOCUMENT SHALL NOT BE DISCLOSED, IN WHOLE OR PART, TO ANY UNAUTHORIZED PERSON OR ENTITY NOR REPRODUCED, TRANSFERRED OR INCORPORATED IN ANY OTHER PROJECT IN ANY MANNER WITHOUT THE EXPRESS WRITTEN CONSENT OF SAMTEC, INC.</p>	<p><b>samtec</b></p> <p>520 PARK EAST BLVD., NEW ALBANY, IN 47150                  PHONE: 812-944-6733 FAX: 812-948-5047                  e-Mail: info@SAMTEC.com code 55322</p>	
	<p>SHEET SCALE: 1:1</p>	<p>DESCRIPTION:                  CUSTOM COM HPC MALE ASSEMBLY</p>
	<p>DWG. NO.                  ASP-214802-02</p>	
<p>F:\DWG\SW\ASP\214000\ASP-214802-02.SLDDRW</p>	<p>BY: R. CURRY</p>	<p>11/05/2020 SHEET 5 OF 8</p>

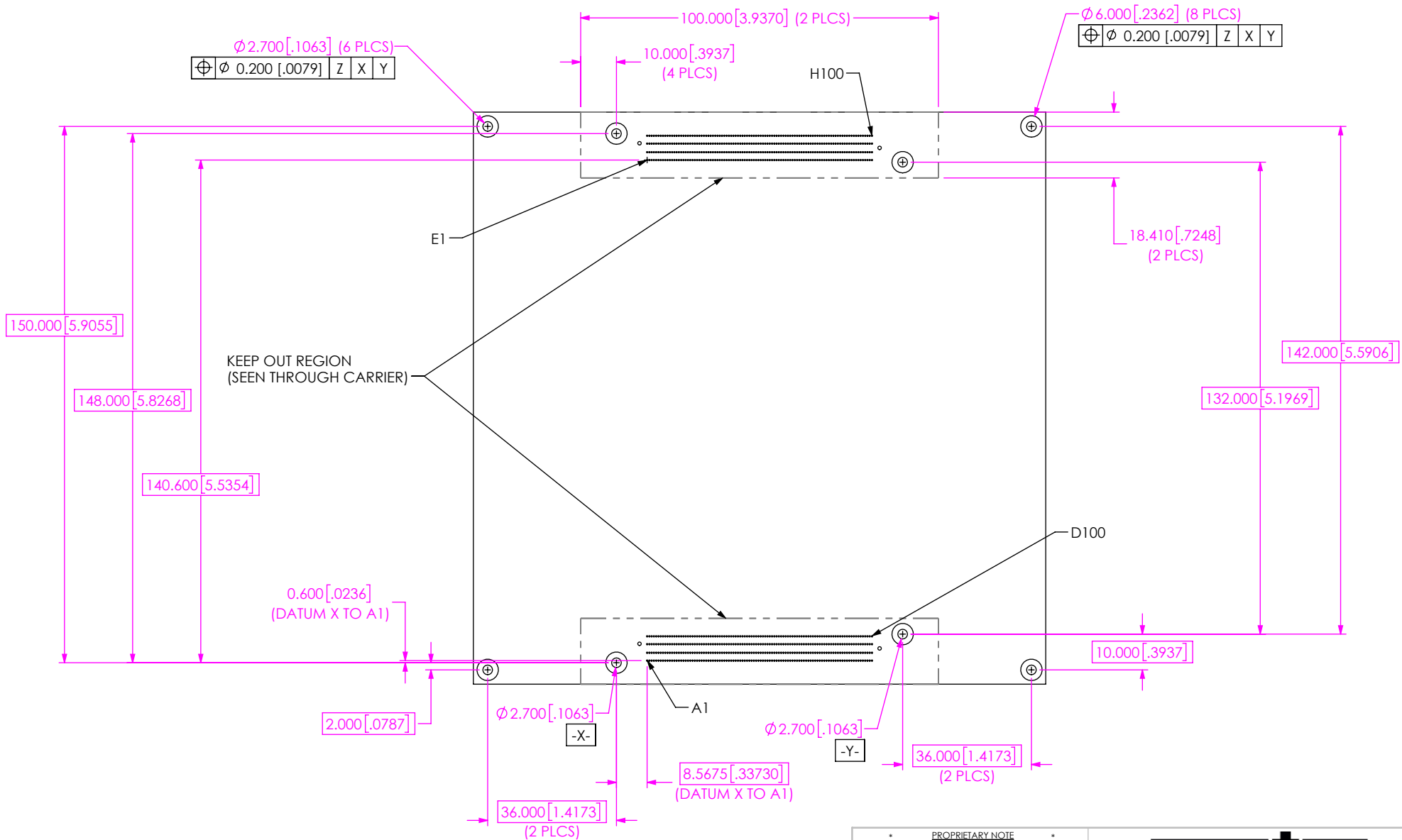

**FIG 4**  
 (RECOMMENDED ASP-214802-02)  
 (SAME AS FIG 2, EXCEPT AS SHOWN)  
 (LAYOUT FOR COM-HPC® MODULE SIZE D)

<p><b>PROPRIETARY NOTE</b></p> <p>THIS DOCUMENT CONTAINS CONFIDENTIAL AND PROPRIETARY INFORMATION AND ALL DESIGN, MANUFACTURING, REPRODUCTION, USE, PATENT RIGHTS AND SALES RIGHTS ARE EXPRESSLY RESERVED BY SAMTEC, INC. THIS DOCUMENT SHALL NOT BE DISCLOSED, IN WHOLE OR PART, TO ANY UNAUTHORIZED PERSON OR ENTITY NOR REPRODUCED, TRANSFERRED OR INCORPORATED IN ANY OTHER PROJECT IN ANY MANNER WITHOUT THE EXPRESS WRITTEN CONSENT OF SAMTEC, INC.</p>	<p><b>samtec</b></p> <p>520 PARK EAST BLVD, NEW ALBANY, IN 47150                  PHONE: 812-944-6733 FAX: 812-948-5047                  e-Mail: info@SAMTEC.com code 55322</p>		
	<p>SHEET SCALE: 1:1</p>	<p>DESCRIPTION:                  CUSTOM COM HPC MALE ASSEMBLY</p>	
	<p>DWG. NO.                  ASP-214802-02</p>		
<p>F:\DWG\SW\ASP\214000\ASP-214802-02.SLDDRW</p>	<p>BY: R. CURRY</p>	<p>11/05/2020</p>	<p>SHEET 6 OF 8</p>

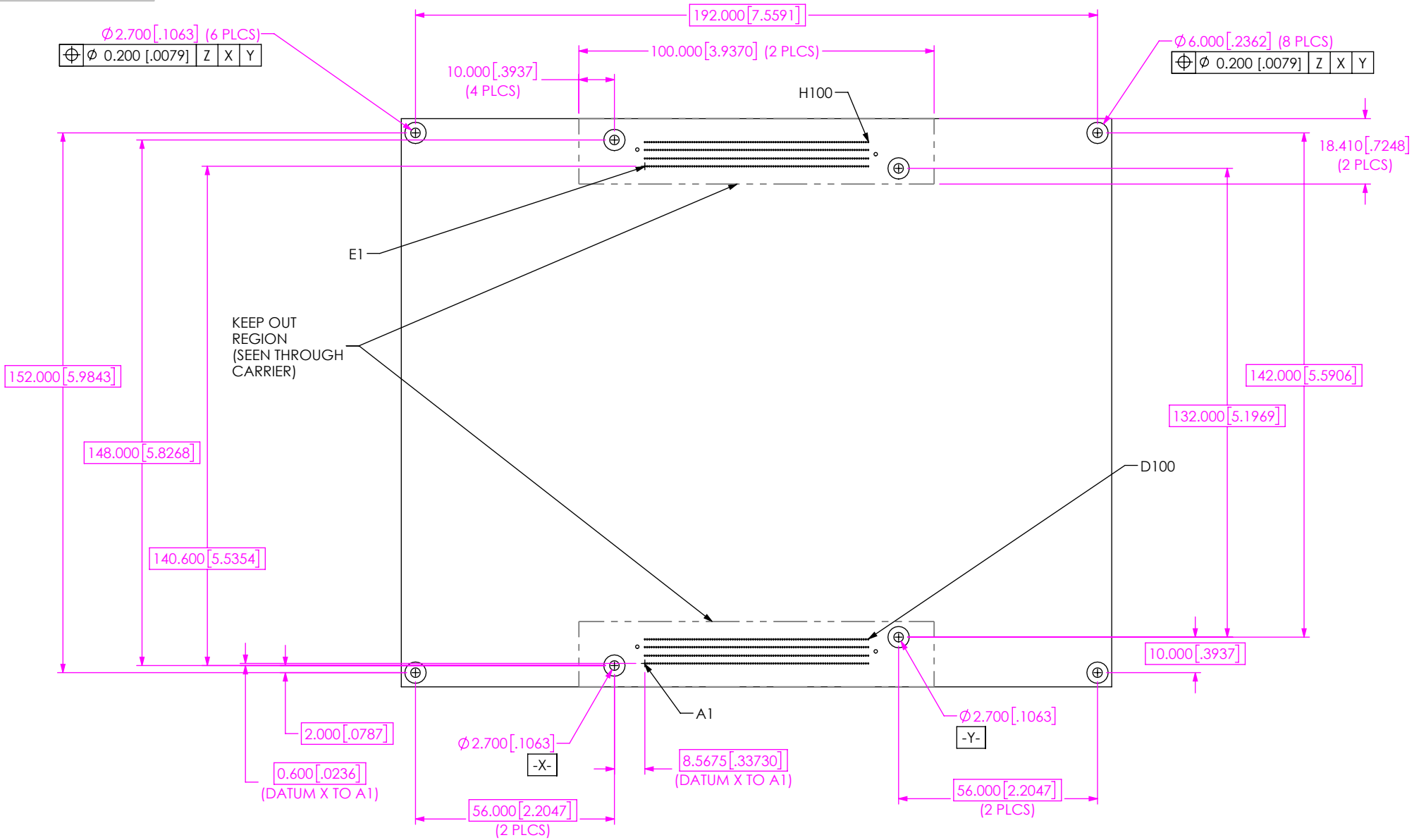

FIG 5  
(RECOMMENDED ASP-214802-02)  
(SAME AS FIG 2, EXCEPT AS SHOWN)  
(LAYOUT FOR COM-HPC® MODULE SIZE E)

**PROPRIETARY NOTE**  
THIS DOCUMENT CONTAINS CONFIDENTIAL AND PROPRIETARY INFORMATION AND ALL DESIGN, MANUFACTURING, REPRODUCTION, USE, PATENT RIGHTS AND SALES RIGHTS ARE EXPRESSLY RESERVED BY SAMTEC, INC. THIS DOCUMENT SHALL NOT BE DISCLOSED, IN WHOLE OR PART, TO ANY UNAUTHORIZED PERSON OR ENTITY NOR REPRODUCED, TRANSFERRED OR INCORPORATED IN ANY OTHER PROJECT IN ANY MANNER WITHOUT THE EXPRESS WRITTEN CONSENT OF SAMTEC, INC.



520 PARK EAST BLVD., NEW ALBANY, IN 47150  
PHONE: 812-944-6733 FAX: 812-948-5047  
e-Mail info@SAMTEC.com code 55322

SHEET SCALE: 1:1  
F:\DWG\SW\ASP\214000\ASP-214802-02.SLDDRW

DESCRIPTION:  
CUSTOM COM HPC MALE ASSEMBLY  
DWG. NO.  
ASP-214802-02  
BY: R. CURRY 11/05/2020 SHEET 7 OF 8

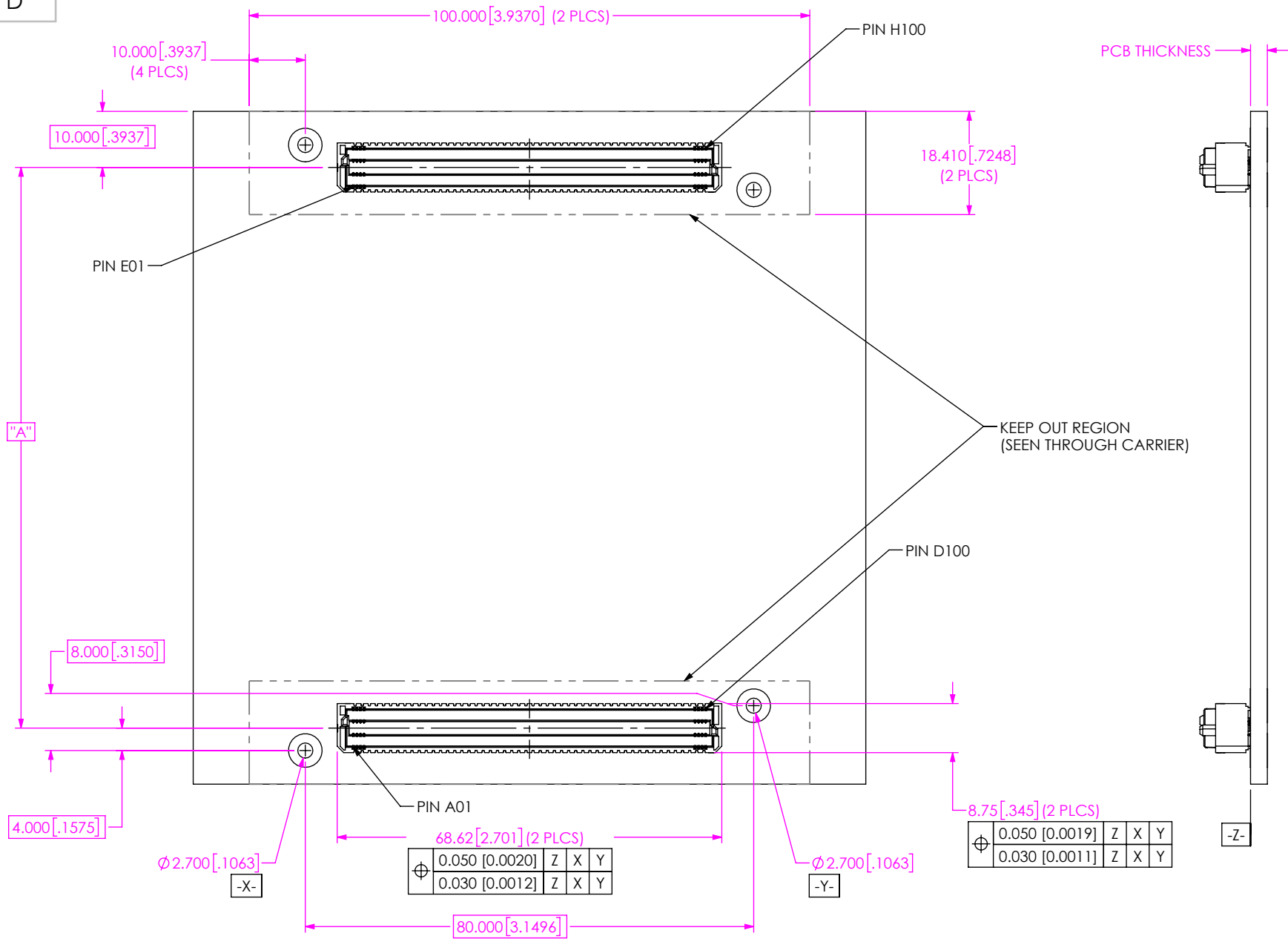

FIG 6  
COM-HPC® ASSEMBLY APPLICATION  
(RECOMMENDED ASP-214802-02 LAYOUT FOR COM-HPC®)

TABLE 1	
COM-HPC® MODULE	"A"
SIZE A	100.000 [3.937]
SIZE B	100.000 [3.937]
SIZE C	100.000 [3.937]
SIZE D	140.000 [5.512]
SIZE E	140.000 [5.512]

**PROPRIETARY NOTE**  
THIS DOCUMENT CONTAINS CONFIDENTIAL AND PROPRIETARY INFORMATION AND ALL DESIGN, MANUFACTURING, REPRODUCTION, USE, PATENT RIGHTS AND SALES RIGHTS ARE EXPRESSLY RESERVED BY SAMTEC, INC. THIS DOCUMENT SHALL NOT BE DISCLOSED, IN WHOLE OR PART, TO ANY UNAUTHORIZED PERSON OR ENTITY NOR REPRODUCED, TRANSFERRED OR INCORPORATED IN ANY OTHER PROJECT IN ANY MANNER WITHOUT THE EXPRESS WRITTEN CONSENT OF SAMTEC, INC.

**samtec**  
520 PARK EAST BLVD, NEW ALBANY, IN 47150  
PHONE: 812-944-6733 FAX: 812-948-5047  
e-Mail info@SAMTEC.com code 55322

DESCRIPTION:  
CUSTOM COM HPC MALE ASSEMBLY

DWG. NO.  
**ASP-214802-02**

BY: R. CURRY 11/05/2020 SHEET 8 OF 8

SHEET SCALE: 1:1

F:\DWG\SW\ASP\214000\ASP-214802-02.SLDDRW