

DO NOT SCALE FROM THIS PRINT

- NOTES:
1. BODY COLOR, POLARIZATION OFFSET NOT AVAILABLE AS STANDARD. REPRESENTS A CRITICAL DIMENSION.
 2. MINIMUM PUSHOUT FORCE: 2.22N[.5 LB] FOR SIGNAL AND WELD TAB.
 3. COPLANARITY MEASUREMENT INCLUDES WT'S.
 4. PARTS TO BE PACKAGED IN TAPE AND REEL.

DESIGNED & DIMENSIONED IN MILLIMETERS [INCHES]

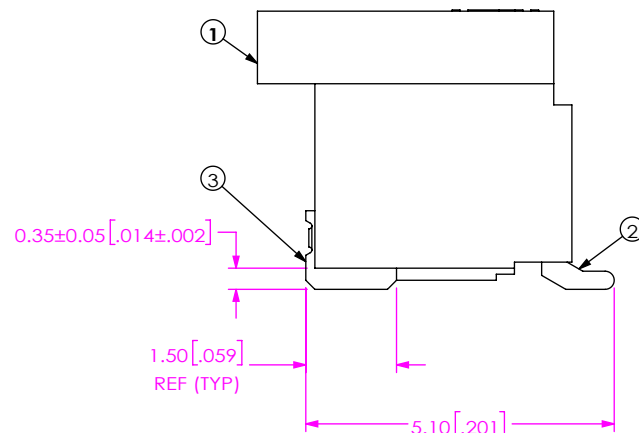
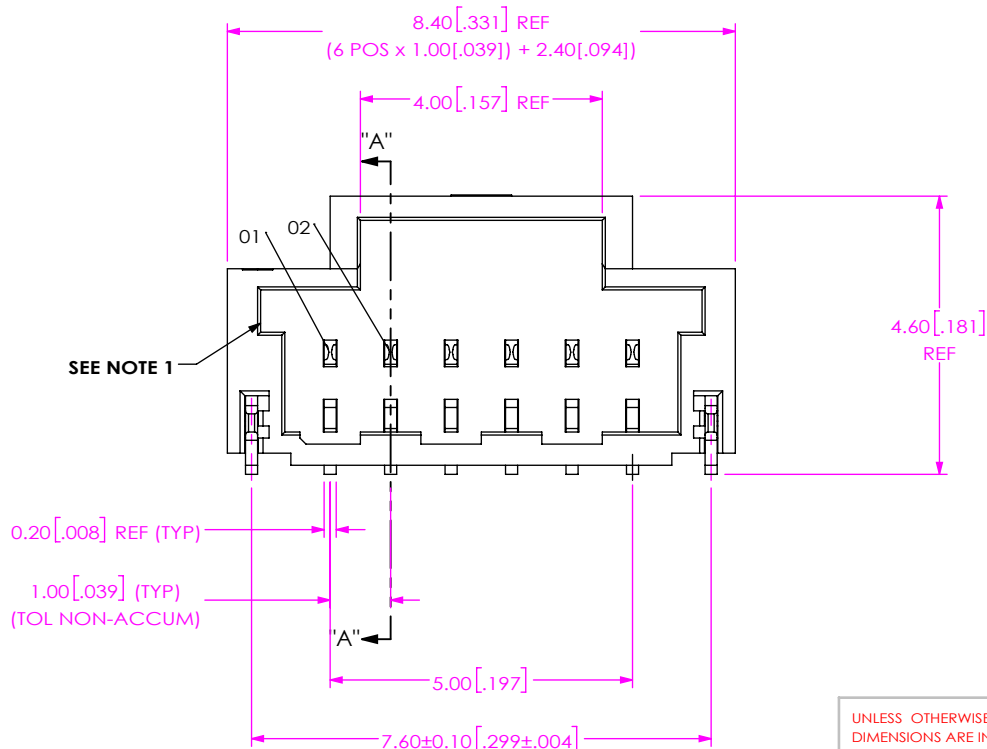
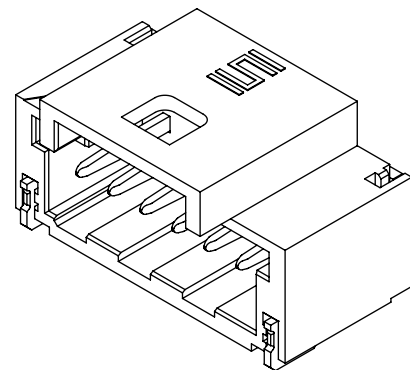
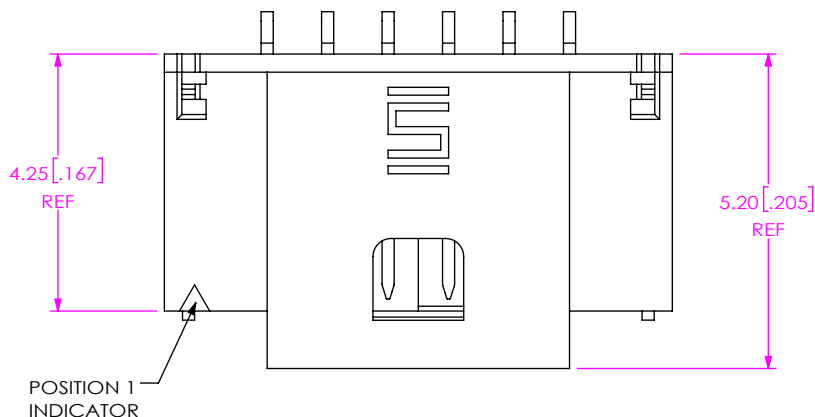

ITEM NO.	PART NUMBER	QUANTITY	MATERIAL
1	ASP-217717-02-B	1.0000	VECTRA E130i, COLOR: ORANGE
2	T-1M123-02-F	6.0000	PHOS BRONZE
3	WT-68-02-T	2.0000	PHOS BRONZE
4	CT-T1M064MS	.00105	CONDUCTIVE POLYMER

UNLESS OTHERWISE SPECIFIED, DIMENSIONS ARE IN MILLIMETERS. TOLERANCES ARE:

DECIMALS	ANGLES
X.X: ±0.3 [.01]	2°
X.XX: ±0.13 [.005]	
X.XXX: ±0.051 [.0020]	

PROPRIETARY NOTE
THIS DOCUMENT CONTAINS CONFIDENTIAL AND PROPRIETARY INFORMATION AND ALL DESIGN, MANUFACTURING, REPRODUCTION, USE, PATENT RIGHTS AND SALES RIGHTS ARE EXPRESSLY RESERVED BY SAMTEC, INC. THIS DOCUMENT SHALL NOT BE DISCLOSED, IN WHOLE OR PART, TO ANY UNAUTHORIZED PERSON OR ENTITY NOR REPRODUCED, TRANSFERRED OR INCORPORATED IN ANY OTHER PROJECT IN ANY MANNER WITHOUT THE EXPRESS WRITTEN CONSENT OF SAMTEC, INC.

DO NOT SCALE DRAWING SHEET SCALE: 8:1

PLATING:
CONTACTS:
CONTACT AREA: .000003" GOLD OVER .000050" NICKEL
REMAINDER: .000200" TIN OVER .000050" NICKEL
WELD TABS:
ENTIRE PIN: .000200" REF TIN OVER .000050" NICKEL

520 PARK EAST BLVD, NEW ALBANY, IN 47150
PHONE: 812-944-6733 FAX: 812-948-5047
e-Mail info@SAMTEC.com code 55322

DESCRIPTION:
MODIFIED T1M ASSEMBLY

DWG. NO.
ASP-217716-02

BY: J. BROWNING 05/07/2020 SHEET 1 OF 2

c:\enterprise\vauf\DWG\MISC\MKTG\ASP-217716-02-MKT.SLDDRW

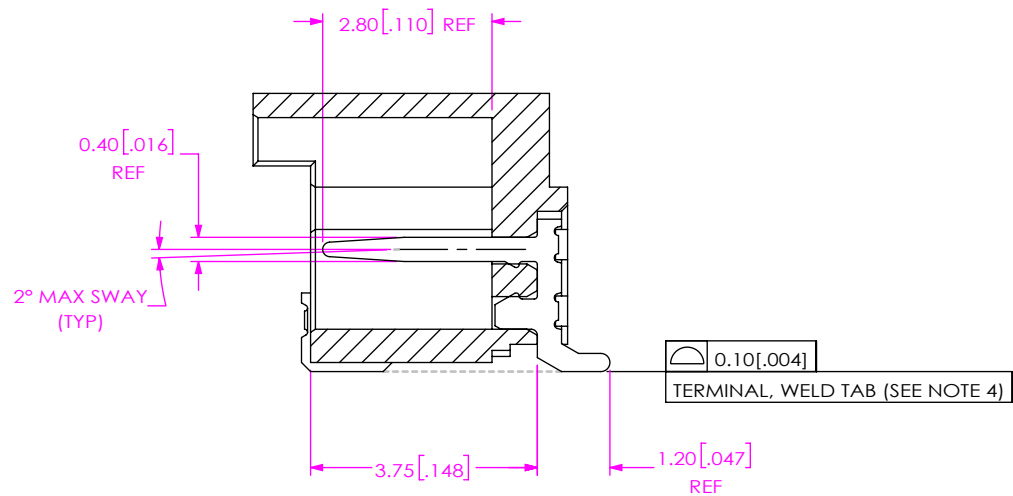

SECTION "A"-"A"

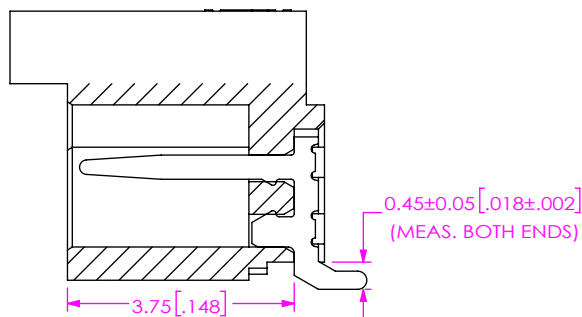

IN-PROCESS 1

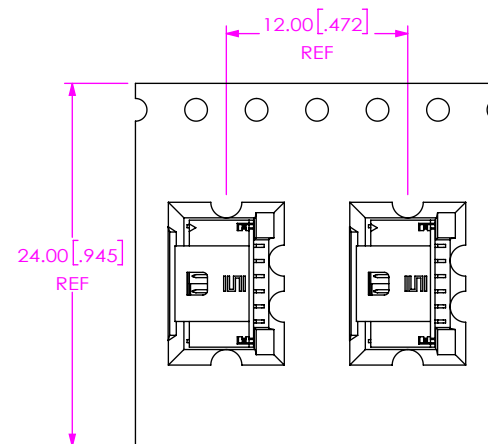

USER DIRECTION OF UN-REELING →
POCKET NOT DETAILED

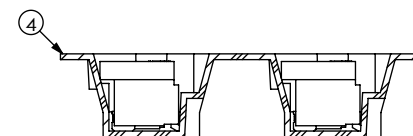

PACKAGING VIEW

PROPRIETARY NOTE

THIS DOCUMENT CONTAINS CONFIDENTIAL AND PROPRIETARY INFORMATION AND ALL DESIGN, MANUFACTURING, REPRODUCTION, USE, PATENT RIGHTS AND SALES RIGHTS ARE EXPRESSLY RESERVED BY SAMTEC, INC. THIS DOCUMENT SHALL NOT BE DISCLOSED, IN WHOLE OR PART, TO ANY UNAUTHORIZED PERSON OR ENTITY NOR REPRODUCED, TRANSFERRED OR INCORPORATED IN ANY OTHER PROJECT IN ANY MANNER WITHOUT THE EXPRESS WRITTEN CONSENT OF SAMTEC, INC.



520 PARK EAST BLVD, NEW ALBANY, IN 47150
PHONE: 812-944-6733 FAX: 812-948-5047
e-Mail: info@SAMTEC.com code 55322

SHEET SCALE: 8:1

DESCRIPTION:
MODIFIED T1M ASSEMBLY

DWG. NO.
ASP-217716-02

BY: J. BROWNING 05/07/2020 SHEET 2 OF 2