

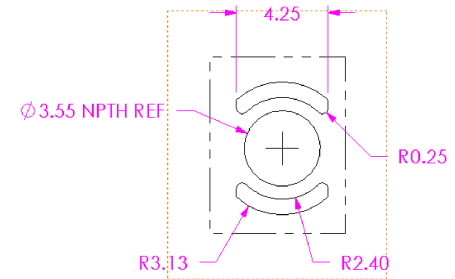

- NOTES:
 1. Ⓢ REPRESENTS A CRITICAL DIMENSION.
 2. PRODUCT TO BE PACKAGED PER KITTING ITEMS IN BAGS STANDARD IN SAMTEC PACKAGING MANUAL.
 3. USE INSERTION TOOL CAT-IN-VNX-GP TO PRESS THE GUIDE PIN INTO THE BOARD.

DO NOT SCALE FROM THIS PRINT

DESIGNED & DIMENSIONED IN INCHES[MILLIMETERS]

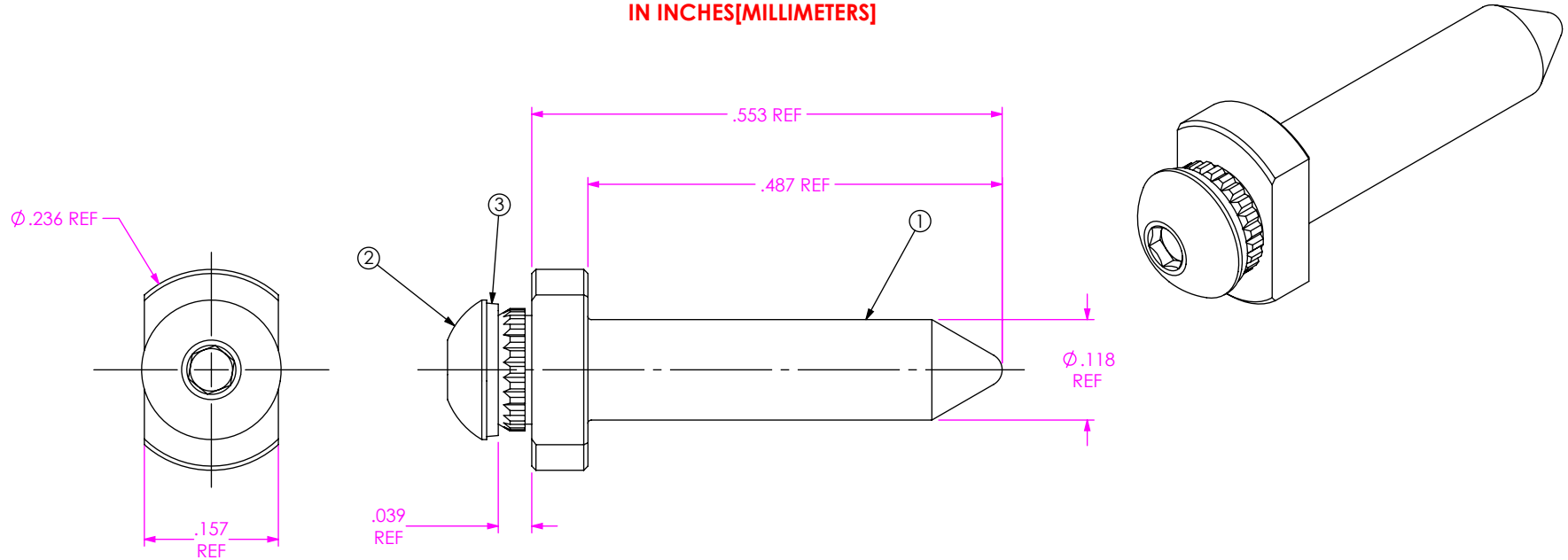

GUIDE FOOTPRINT

UNLESS OTHERWISE SPECIFIED, DIMENSIONS ARE IN INCHES. TOLERANCES ARE: DECIMALS ANGLES .XX: $\pm .01$ 2° .XXX: $\pm .002$.XXXX: $\pm .0005$	* PROPRIETARY NOTE * THIS DOCUMENT CONTAINS CONFIDENTIAL AND PROPRIETARY INFORMATION AND ALL DESIGN, MANUFACTURING, REPRODUCTION, USE, PATENT RIGHTS AND SALES RIGHTS ARE EXPRESSLY RESERVED BY SAMTEC, INC. THIS DOCUMENT SHALL NOT BE DISCLOSED, IN WHOLE OR PART, TO ANY UNAUTHORIZED PERSON OR ENTITY NOR REPRODUCED, TRANSFERRED OR INCORPORATED IN ANY OTHER PROJECT IN ANY MANNER WITHOUT THE EXPRESS WRITTEN CONSENT OF SAMTEC, INC.		
		520 PARK EAST BLVD., NEW ALBANY, IN 47150 PHONE: 812-944-6733 FAX: 812-948-5047 e-Mail: info@SAMTEC.com code 55322	
DO NOT SCALE DRAWING SHEET SCALE: 5:1		DESCRIPTION: VNX+ ALIGNMENT PIN ASSEMBLY	
MATERIAL: ALIGNMENT PIN: BRASS SCREW & WASHER: STAINLESS STEEL FINISH: ALIGNMENT PIN: NICKEL SCREW & WASHER: PASSIVATED		DWG. NO. ASP-222868-01	
F:\DWG\MISC\Mktg\ASP-222868-01-MKT.SLDDRW		BY: ADAM H. 11/2/2021 SHEET 1 OF 2	

ITEM NO.	PART NUMBER	QUANTITY	DESCRIPTION
1	ASP-223418-02-P-N	1.0000	ALIGNMENT PIN
2	CCS-224176-02-SCR	1.0000	SCREW
3	CCS-224175-02-MC	1.0000	WASHER

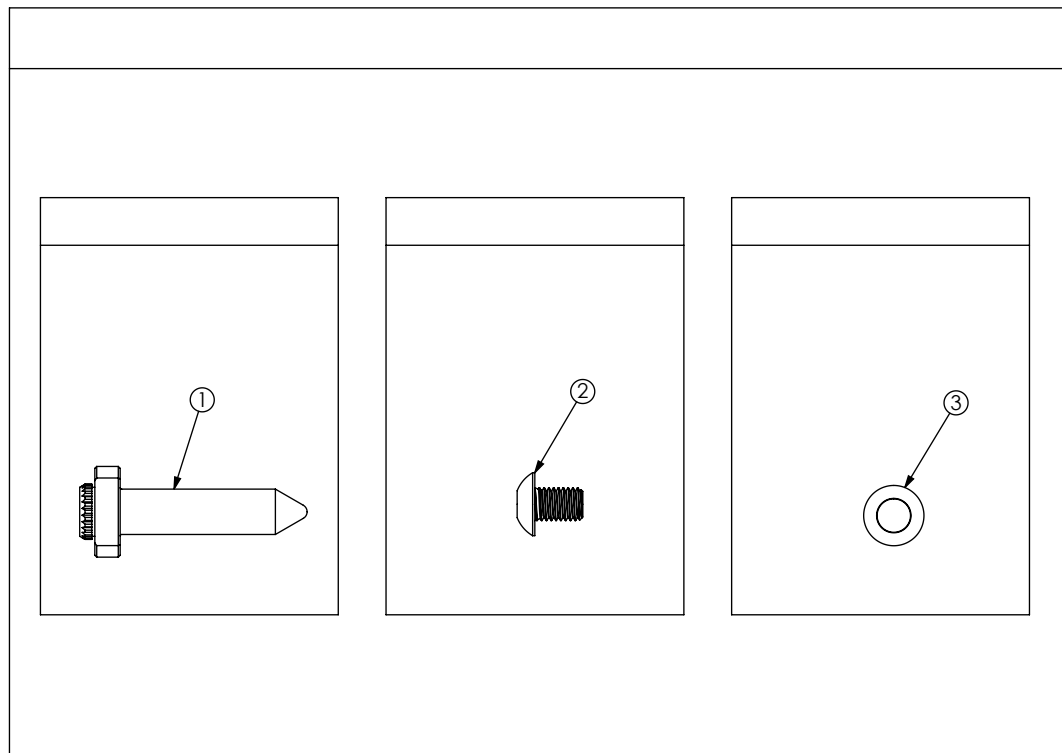

PACKAGING VIEW
NOT TO SCALE
 (ONLY ONE ITEM SHOWN PER BAG FOR CLARITY ONLY)

PROPRIETARY NOTE

THIS DOCUMENT CONTAINS CONFIDENTIAL AND PROPRIETARY INFORMATION AND ALL DESIGN, MANUFACTURING, REPRODUCTION, USE, PATENT RIGHTS AND SALES RIGHTS ARE EXPRESSLY RESERVED BY SAMTEC, INC. THIS DOCUMENT SHALL NOT BE DISCLOSED, IN WHOLE OR PART, TO ANY UNAUTHORIZED PERSON OR ENTITY NOR REPRODUCED, TRANSFERRED OR INCORPORATED IN ANY OTHER PROJECT IN ANY MANNER WITHOUT THE EXPRESS WRITTEN CONSENT OF SAMTEC, INC.



520 PARK EAST BLVD, NEW ALBANY, IN 47150
 PHONE: 812-944-6733 FAX: 812-948-5047
 e-Mail info@SAMTEC.com code 55322

SHEET SCALE: 4:1

DESCRIPTION:
 VNX+ ALIGNMENT PIN ASSEMBLY

DWG. NO.
 ASP-222868-01