

DO NOT
SCALE FROM
THIS PRINT

SOME CENTER FEATURES
NOT SHOWN FOR CLARITY

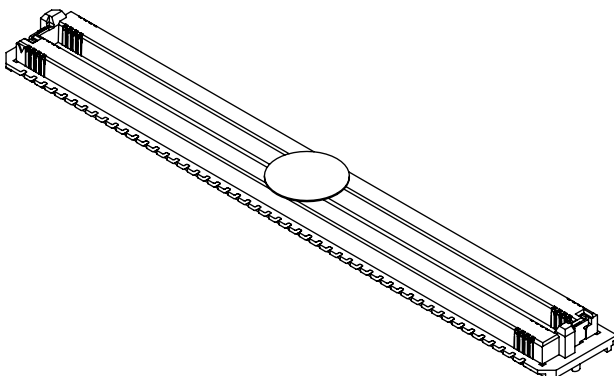
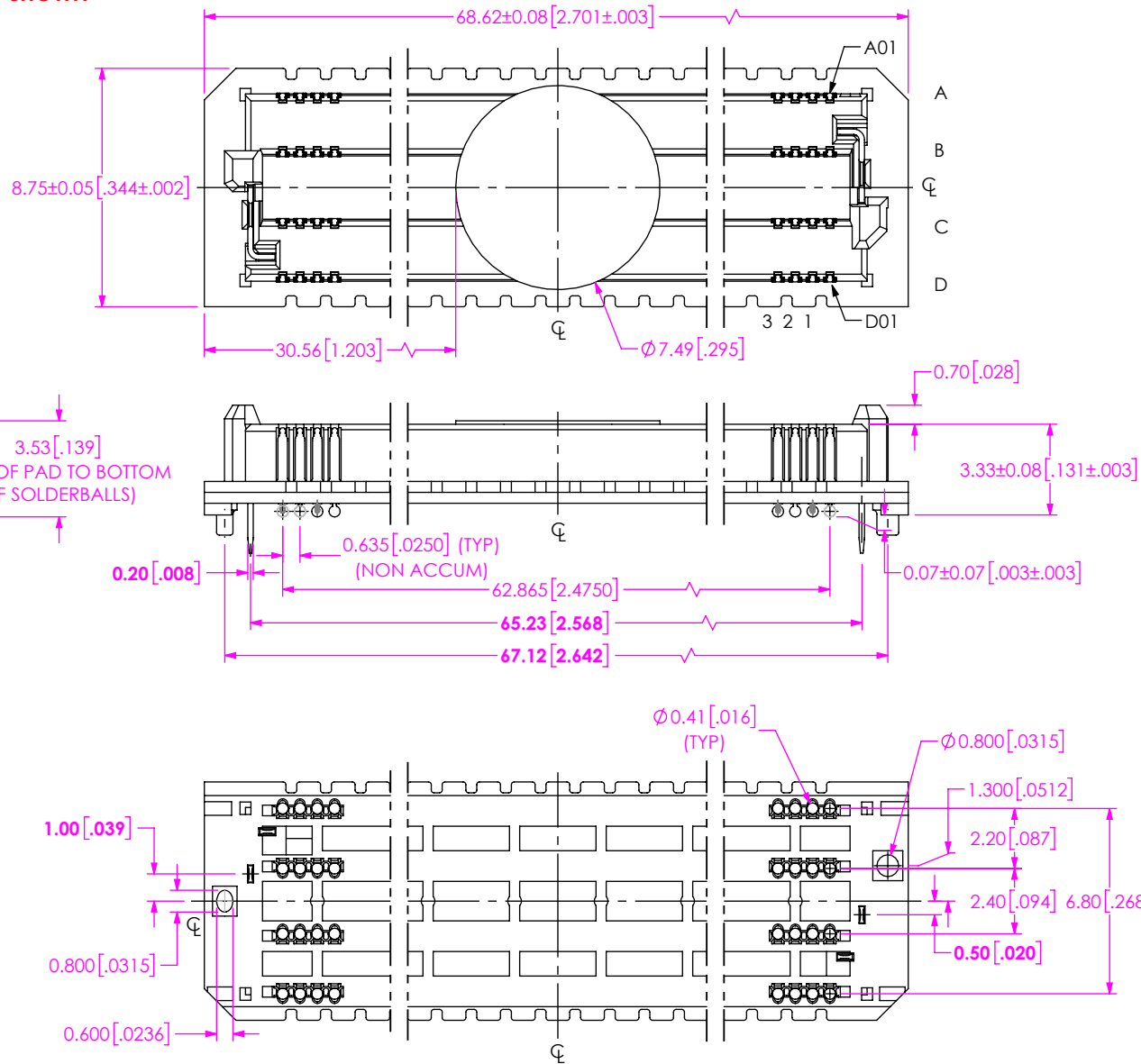
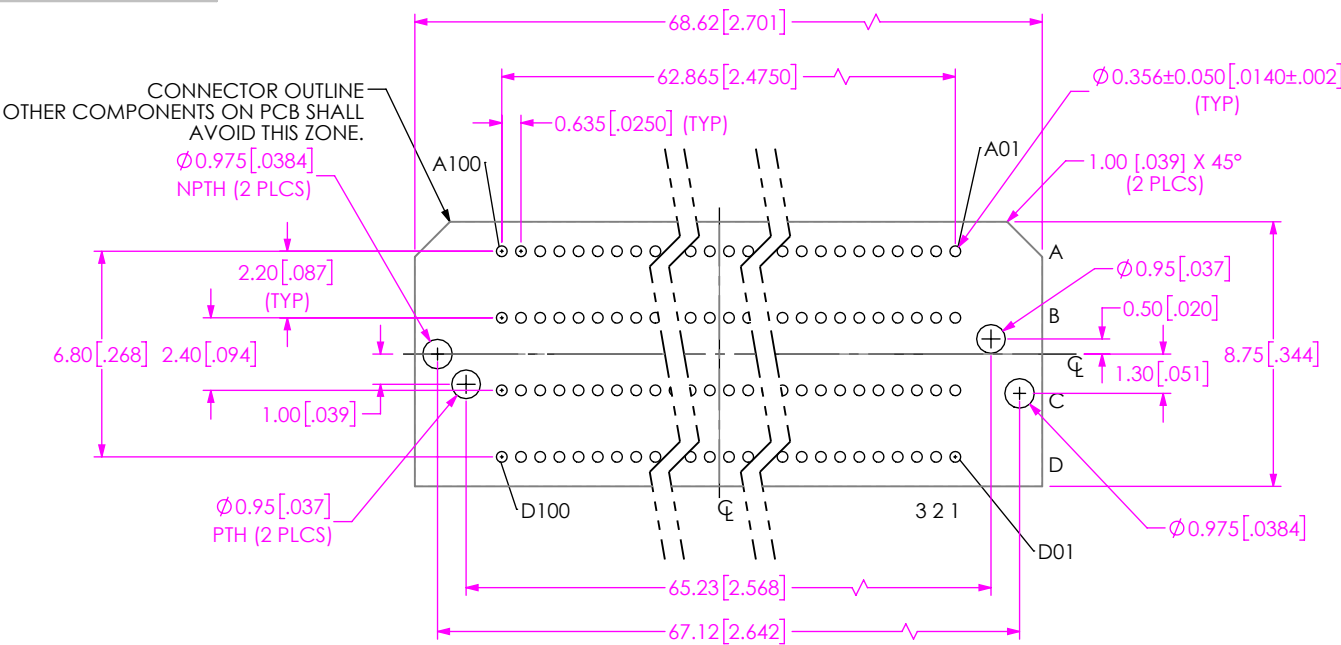

FIG 1
(ASP-230333-02 SHOWN)

NOTES:

1. ATTACH LABEL -4X2 TO EACH REEL.
2. ORDERS WILL BE PACKAGED ACCORDING TO THE SAMTEC PACKAGING EFFICIENCY STANDARDS (SPES) FOUND ON WWW.SAMTEC.COM.

<p>PROPRIETARY NOTE</p> <p>THIS DOCUMENT CONTAINS CONFIDENTIAL AND PROPRIETARY INFORMATION AND ALL DESIGN, MANUFACTURING, REPRODUCTION, USE, PATENT RIGHTS AND SALES RIGHTS ARE EXPRESSLY RESERVED BY SAMTEC, INC. THIS DOCUMENT SHALL NOT BE DISCLOSED, IN WHOLE OR PART, TO ANY UNAUTHORIZED PERSON OR ENTITY NOR REPRODUCED, TRANSFERRED OR INCORPORATED IN ANY OTHER PROJECT IN ANY MANNER WITHOUT THE EXPRESS WRITTEN CONSENT OF SAMTEC, INC.</p>		<p>samtec</p> <p>520 PARK EAST BLVD, NEW ALBANY, IN 47150 PHONE: 812-944-6733 FAX: 812-948-5047 e-Mail: info@SAMTEC.com code 53322</p>
DO NOT SCALE DRAWING	SHEET SCALE: 4:1	
<p>MATERIAL: INSULATOR: LCP, COLOR BLACK CONTACT: COPPER ALLOY WELD TAB: COPPER ALLOY</p> <p>PLATING: TERMINAL: CONTACT AREA: .000300" REF GOLD REMAINDER: .000200" REF TIN WELD TAB: ENTIRE PIN: .000200" REF TIN</p>		DWG. NO. ASP-230333-02
		BY: JACK Z 5/11/2023 SHEET 1 OF 8



RECOMMENDED PCB LAYOUT
 ALL DIMENSIONS SYMMETRIC ABOUT CENTERLINE
 ALL DIMENSIONS FOR REFERENCE ONLY

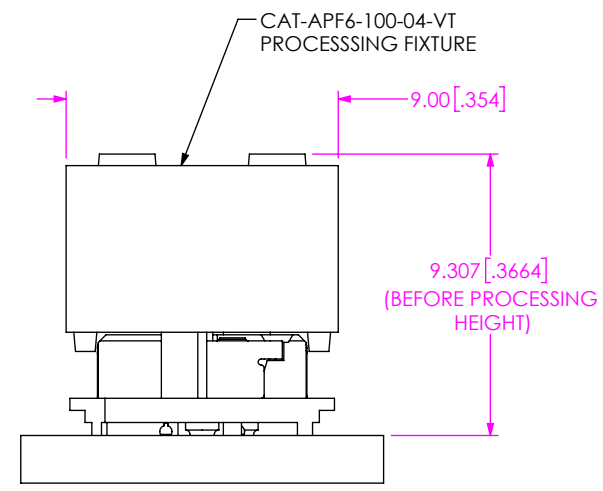

PROCESSING VIEW
 DIMENSION INDICATES CONNECTOR/FIXTURE HEIGHT ON PCB TO GUARANTEE ENOUGH REFLOW OVEN WORKING SPACE. DIMENSION, PCB THICKNESS, AND THE HEIGHT OF THE COMPONENTS ON THE OTHER SIDE OF THE BOARD NEED TO BE CONSIDERED.

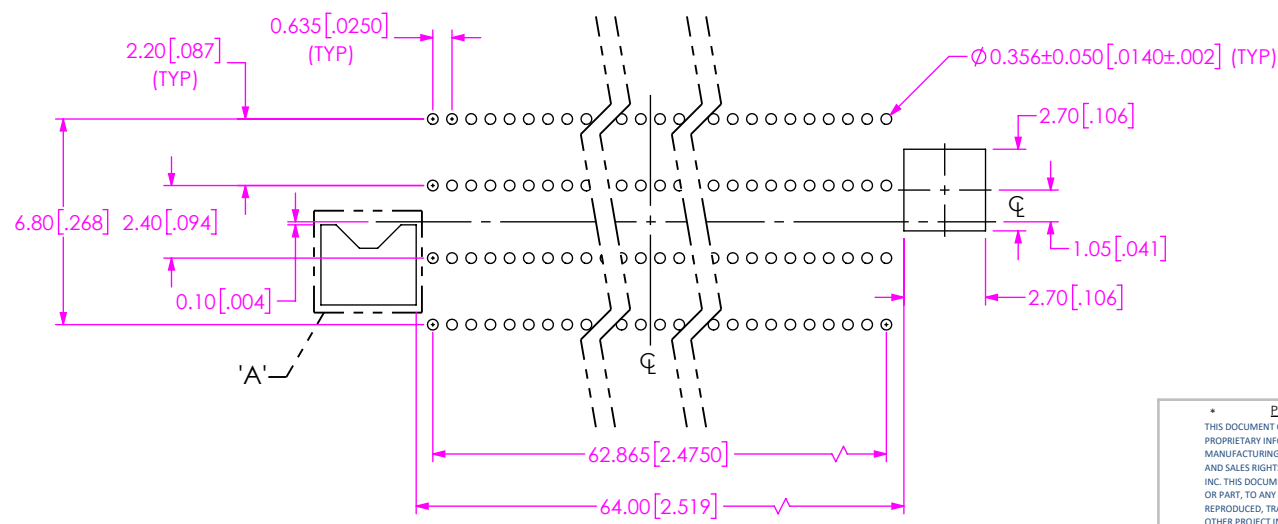

RECOMMENDED STENCIL LAYOUT
 ALL DIMENSIONS SYMMETRIC ABOUT CENTERLINE
 (STENCIL TO BE 0.125 [0.0050] THICK)

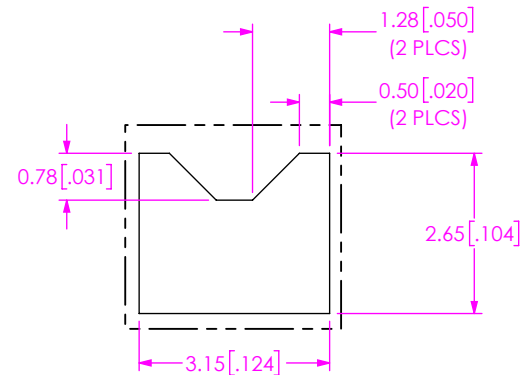

DETAIL 'A'
 SCALE 8 : 1

<p>PROPRIETARY NOTE</p> <p>THIS DOCUMENT CONTAINS CONFIDENTIAL AND PROPRIETARY INFORMATION AND ALL DESIGN, MANUFACTURING, REPRODUCTION, USE, PATENT RIGHTS AND SALES RIGHTS ARE EXPRESSLY RESERVED BY SAMTEC, INC. THIS DOCUMENT SHALL NOT BE DISCLOSED, IN WHOLE OR PART, TO ANY UNAUTHORIZED PERSON OR ENTITY NOR REPRODUCED, TRANSFERRED OR INCORPORATED IN ANY OTHER PROJECT IN ANY MANNER WITHOUT THE EXPRESS WRITTEN CONSENT OF SAMTEC, INC.</p>	<p>samtec</p> <p>520 PARK EAST BLVD. NEW ALBANY, IN 47150 PHONE: 812-944-6733 FAX: 812-948-5047 e-Mail info@SAMTEC.com code 55322</p>	
	<p>SHEET SCALE: 2:1</p>	<p>DESCRIPTION: CUSTOM COM HPC MALE ASSEMBLY</p>
	<p>DWG. NO. ASP-230333-02</p>	<p>BY: JACK Z 5/11/2023 SHEET 2 OF 8</p>

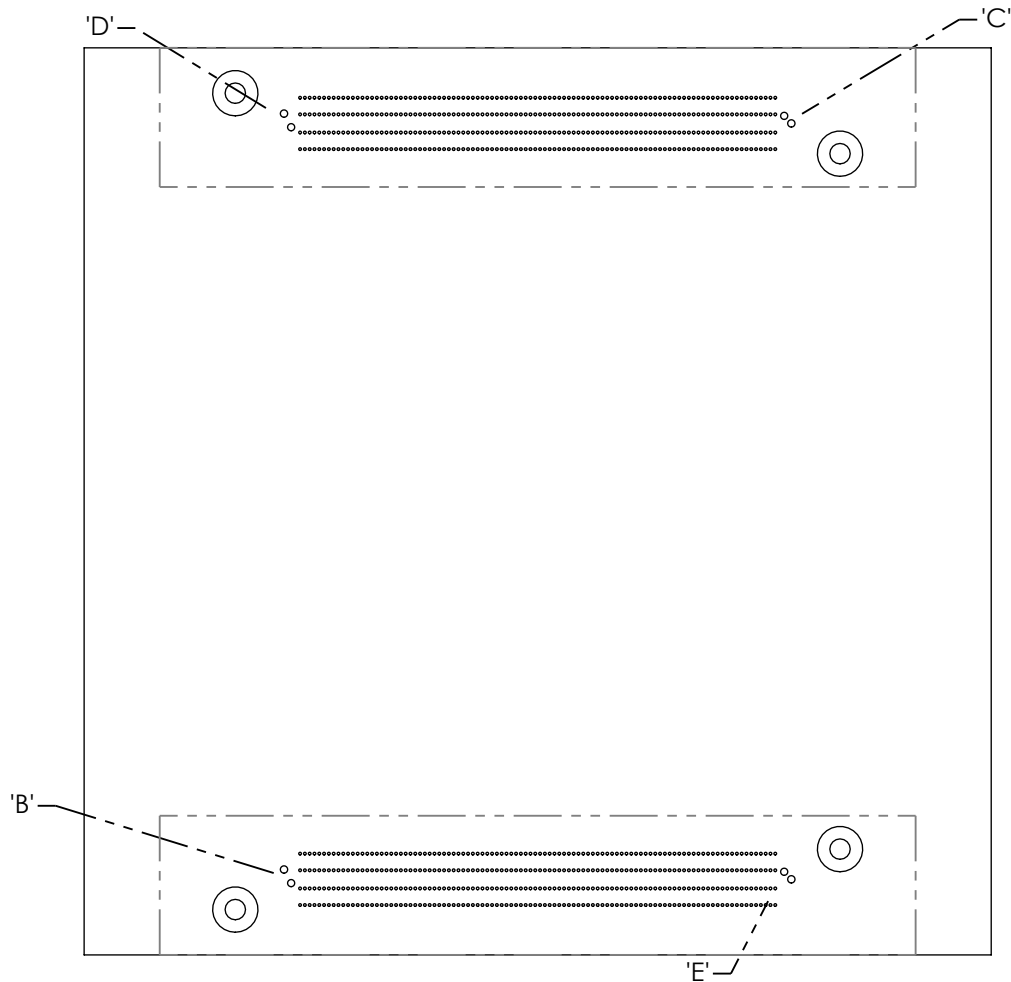

FIG 2
 (RECOMMENDED ASP-230333-02)
 (LAYOUT FOR COM-HPC® MODULE SIZE A & B)

PROPRIETARY NOTE

THIS DOCUMENT CONTAINS CONFIDENTIAL AND PROPRIETARY INFORMATION AND ALL DESIGN, MANUFACTURING, REPRODUCTION, USE, PATENT RIGHTS AND SALES RIGHTS ARE EXPRESSLY RESERVED BY SAMTEC, INC. THIS DOCUMENT SHALL NOT BE DISCLOSED, IN WHOLE OR PART, TO ANY UNAUTHORIZED PERSON OR ENTITY NOR REPRODUCED, TRANSFERRED OR INCORPORATED IN ANY OTHER PROJECT IN ANY MANNER WITHOUT THE EXPRESS WRITTEN CONSENT OF SAMTEC, INC.

SHEET SCALE: 1:1



520 PARK EAST BLVD, NEW ALBANY, IN 47150
 PHONE: 812-944-6733 FAX: 812-948-5047
 e-Mail info@SAMTEC.com code 55322

DESCRIPTION:
 CUSTOM COM HPC MALE ASSEMBLY

DWG. NO.
ASP-230333-02

BY: JACK Z 5/11/2023 SHEET 3 OF 8

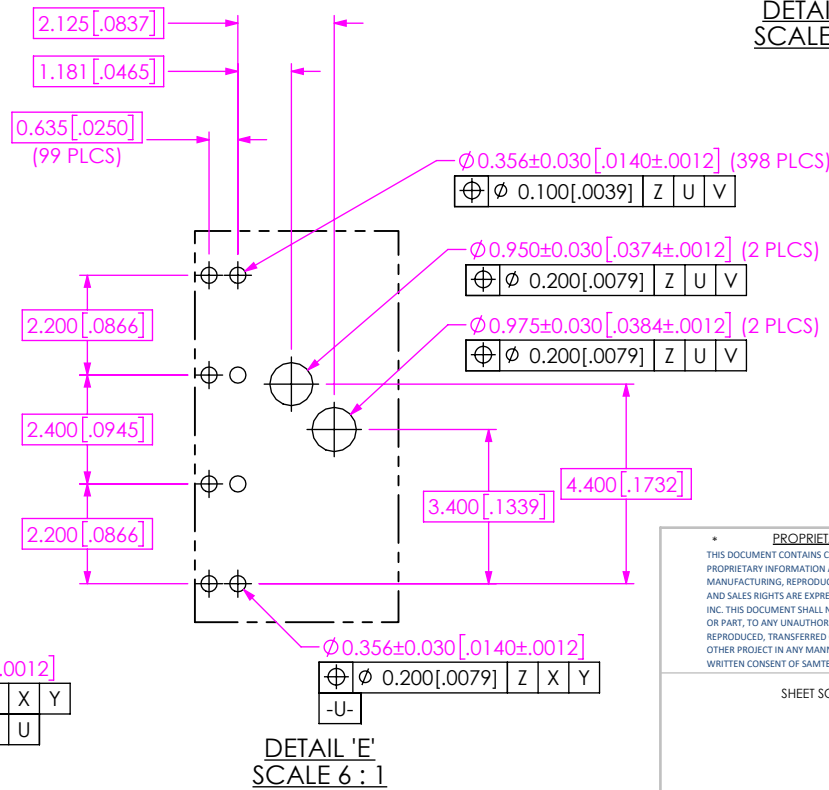
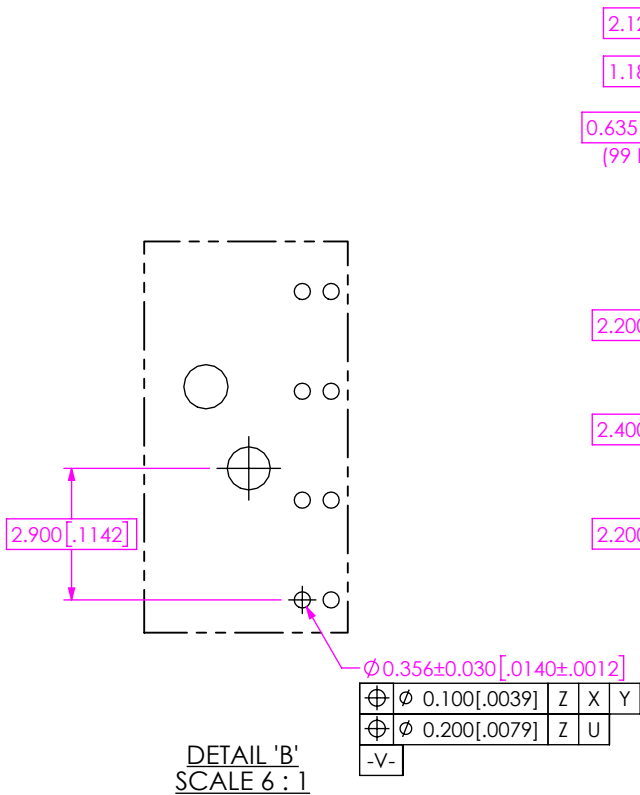
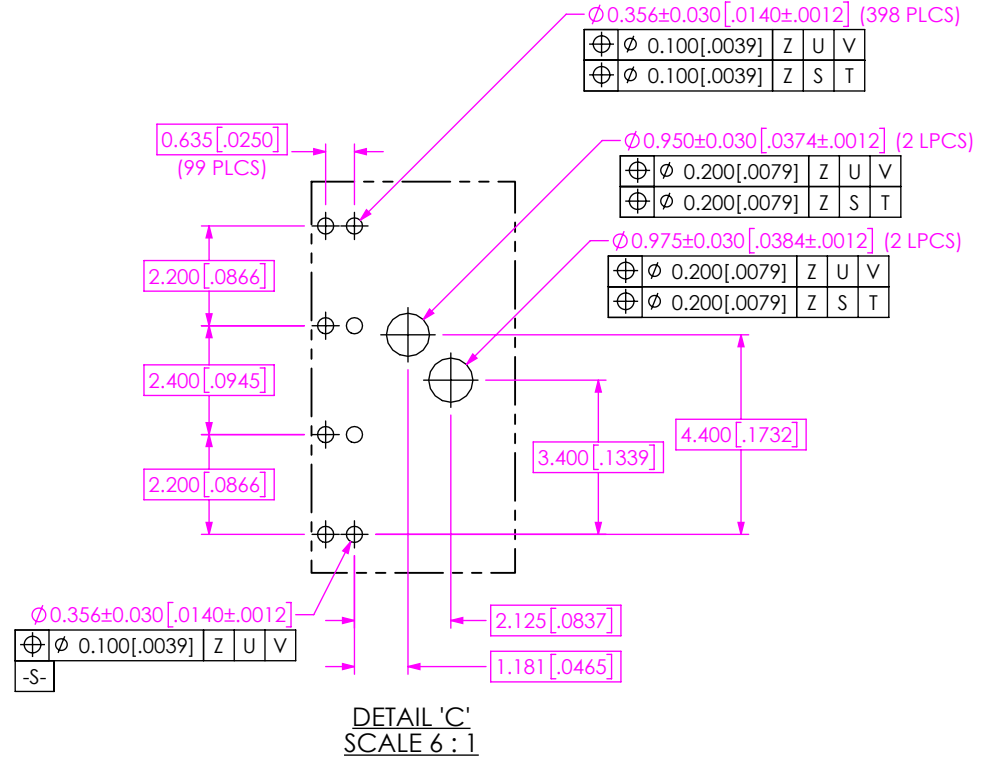
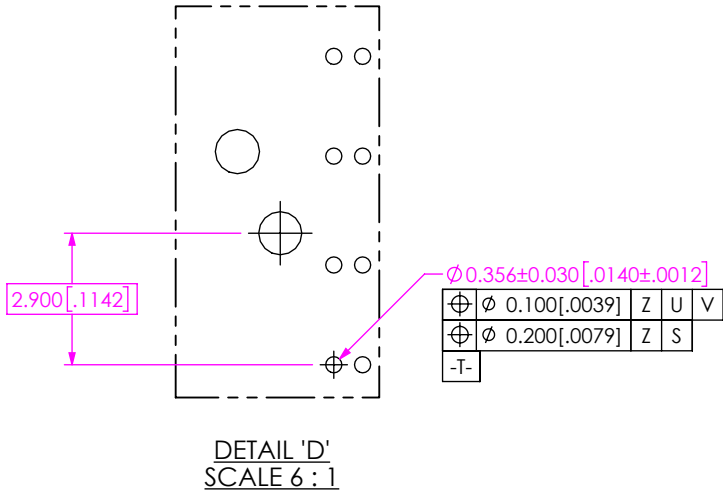

PROPRIETARY NOTE
 THIS DOCUMENT CONTAINS CONFIDENTIAL AND PROPRIETARY INFORMATION AND ALL DESIGN, MANUFACTURING, REPRODUCTION, USE, PATENT RIGHTS AND SALES RIGHTS ARE EXPRESSLY RESERVED BY SAMTEC, INC. THIS DOCUMENT SHALL NOT BE DISCLOSED, IN WHOLE OR PART, TO ANY UNAUTHORIZED PERSON OR ENTITY NOR REPRODUCED, TRANSFERRED OR INCORPORATED IN ANY OTHER PROJECT IN ANY MANNER WITHOUT THE EXPRESS WRITTEN CONSENT OF SAMTEC, INC.



520 PARK EAST BLVD, NEW ALBANY, IN 47150
 PHONE: 812-944-6733 FAX: 812-948-5047
 e-Mail: info@SAMTEC.com code 55322

SHEET SCALE: 1:1

DESCRIPTION:
 CUSTOM COM HPC MALE ASSEMBLY

DWG. NO.
 ASP-230333-02

BY: JACK Z 5/11/2023 SHEET 4 OF 8

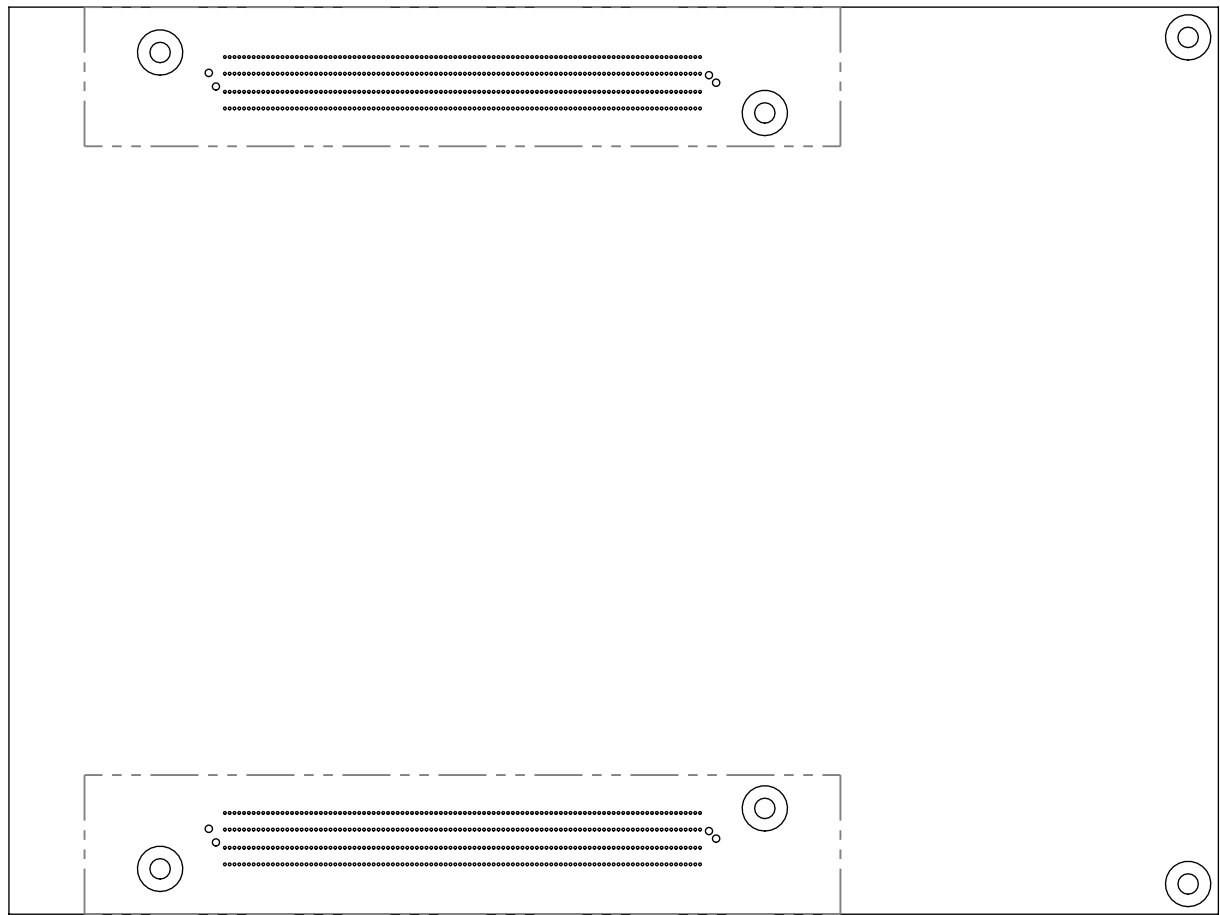

FIG 3
 (RECOMMENDED ASP-230333-02)
 (SAME AS FIG 2, EXCEPT AS SHOWN)
 (LAYOUT FOR COM-HPC® MODULE SIZE C)

c:\enterprisevault\DWG\MISC\MKTG\ASP-230333-02-MKT.SLDDRW

PROPRIETARY NOTE
 * THIS DOCUMENT CONTAINS CONFIDENTIAL AND PROPRIETARY INFORMATION AND ALL DESIGN, MANUFACTURING, REPRODUCTION, USE, PATENT RIGHTS AND SALES RIGHTS ARE EXPRESSLY RESERVED BY SAMTEC, INC. THIS DOCUMENT SHALL NOT BE DISCLOSED, IN WHOLE OR PART, TO ANY UNAUTHORIZED PERSON OR ENTITY NOR REPRODUCED, TRANSFERRED OR INCORPORATED IN ANY OTHER PROJECT IN ANY MANNER WITHOUT THE EXPRESS WRITTEN CONSENT OF SAMTEC, INC. *

SHEET SCALE: 1:1



520 PARK EAST BLVD, NEW ALBANY, IN 47150
 PHONE: 812-944-6733 FAX: 812-948-5047
 e-Mail info@SAMTEC.com code 55322

DESCRIPTION:
 CUSTOM COM HPC MALE ASSEMBLY

DWG. NO. **ASP-230333-02**

BY: JACK Z 5/11/2023 SHEET 5 OF 8

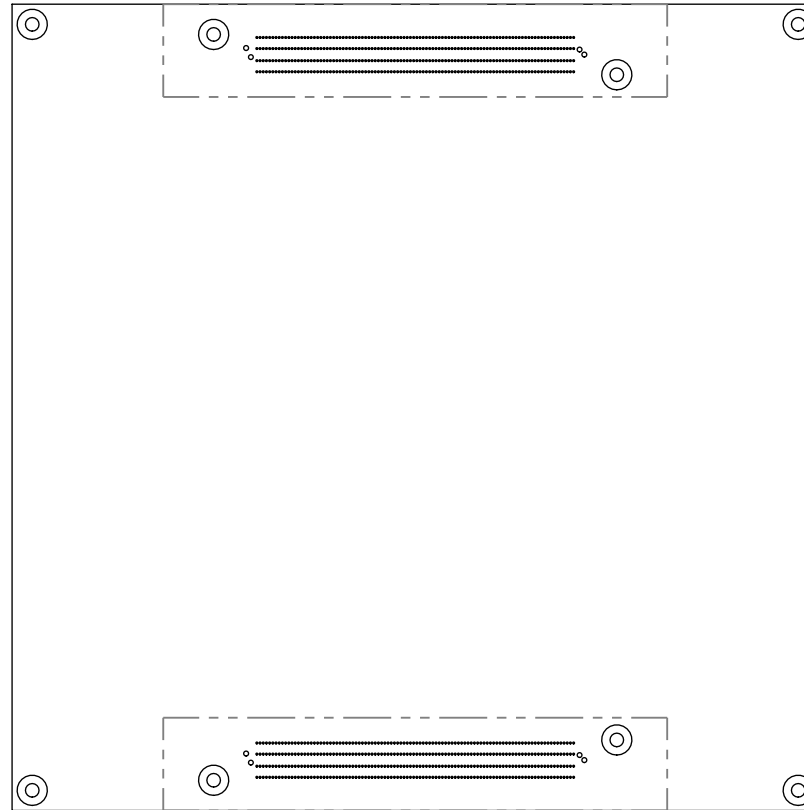

FIG 4
 (RECOMMENDED ASP-230333-02)
 (SAME AS FIG 2, EXCEPT AS SHOWN)
 (LAYOUT FOR COM-HPC® MODULE SIZE D)

c:\enterprise\vault\DWG\MISC\MKTG\ASP-230333-02-MKT.SLDDRW

<p style="text-align: center;">PROPRIETARY NOTE</p> <p style="font-size: small;">THIS DOCUMENT CONTAINS CONFIDENTIAL AND PROPRIETARY INFORMATION AND ALL DESIGN, MANUFACTURING, REPRODUCTION, USE, PATENT RIGHTS AND SALES RIGHTS ARE EXPRESSLY RESERVED BY SAMTEC, INC. THIS DOCUMENT SHALL NOT BE DISCLOSED, IN WHOLE OR PART, TO ANY UNAUTHORIZED PERSON OR ENTITY NOR REPRODUCED, TRANSFERRED OR INCORPORATED IN ANY OTHER PROJECT IN ANY MANNER WITHOUT THE EXPRESS WRITTEN CONSENT OF SAMTEC, INC.</p>	<p style="text-align: center;">samtec</p> <p style="font-size: x-small;">520 PARK EAST BLVD, NEW ALBANY, IN 47150 PHONE: 812-944-6733 FAX: 812-948-5047 e-Mail info@SAMTEC.com code 55322</p>
<p style="text-align: center;">SHEET SCALE: 1:1</p>	<p>DESCRIPTION: CUSTOM COM HPC MALE ASSEMBLY</p>
	<p>DWG. NO. ASP-230333-02</p>
	<p>BY: JACK Z 5/11/2023 SHEET 6 OF 8</p>

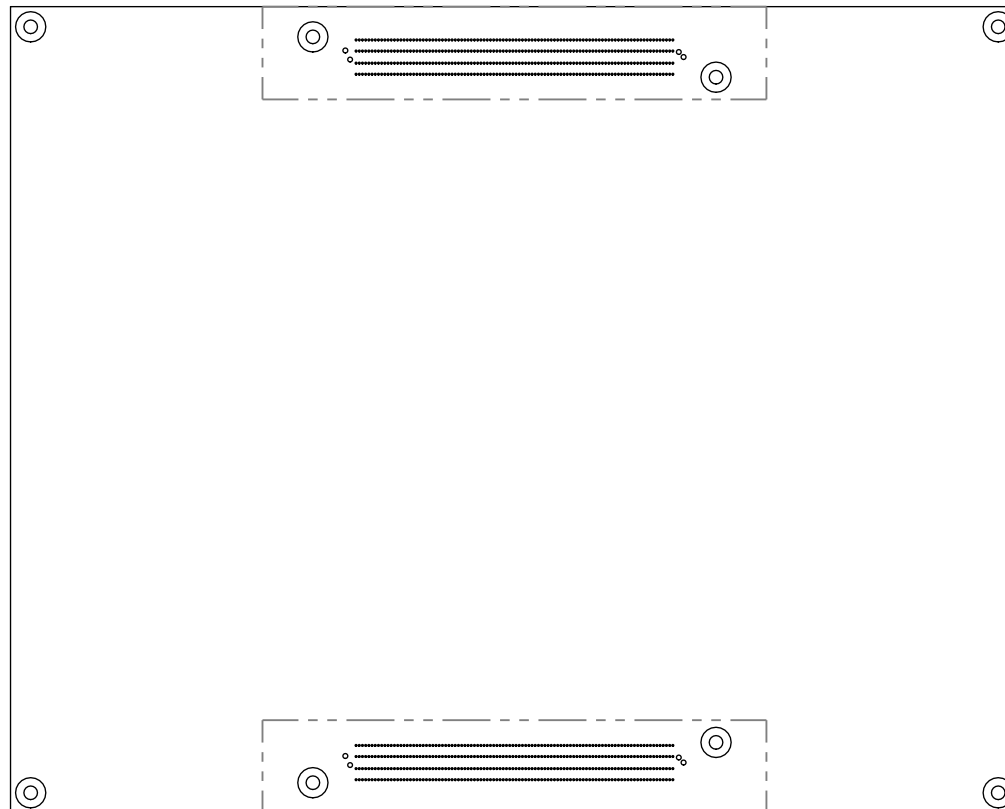
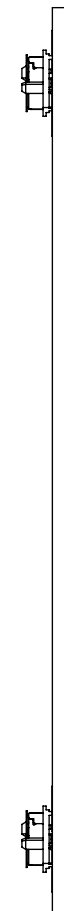
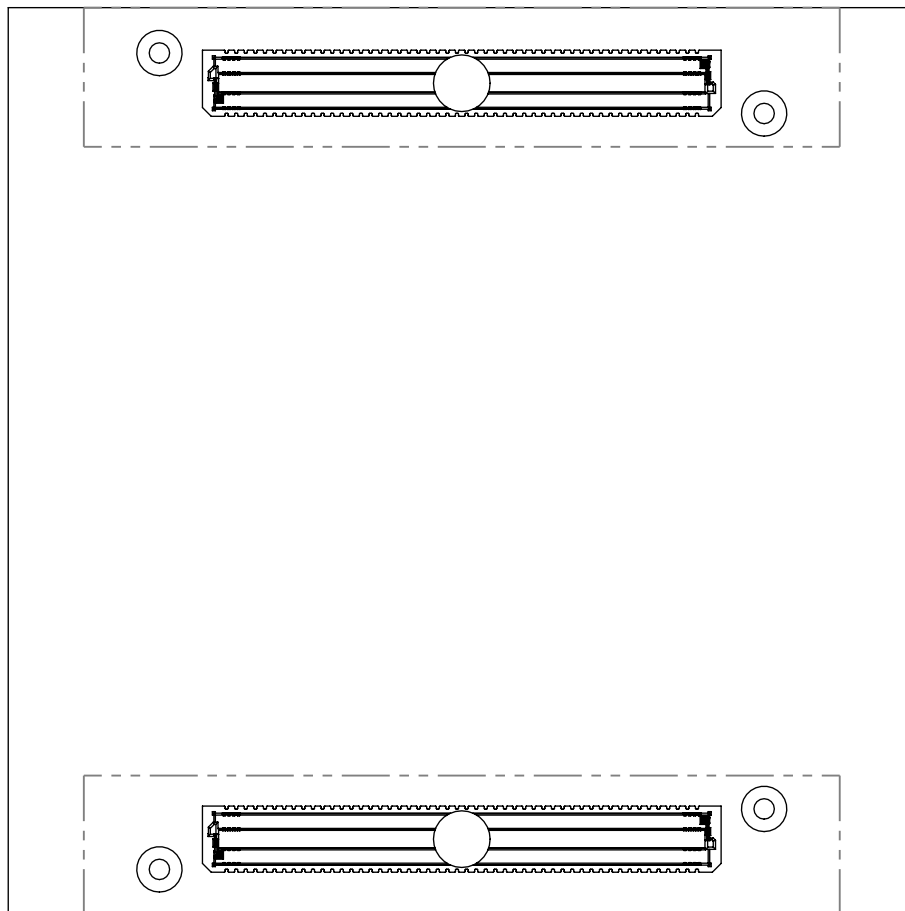

FIG 5
 (RECOMMENDED ASP-230333-02)
 (SAME AS FIG 2, EXCEPT AS SHOWN)
 (LAYOUT FOR COM-HPC® MODULE SIZE E)

c:\enterprisevault\DWG\MISC\MKTG\ASP-230333-02-MKT.SLDDRW

<p style="text-align: center;">* PROPRIETARY NOTE *</p> <p>THIS DOCUMENT CONTAINS CONFIDENTIAL AND PROPRIETARY INFORMATION AND ALL DESIGN, MANUFACTURING, REPRODUCTION, USE, PATENT RIGHTS AND SALES RIGHTS ARE EXPRESSLY RESERVED BY SAMTEC, INC. THIS DOCUMENT SHALL NOT BE DISCLOSED, IN WHOLE OR PART, TO ANY UNAUTHORIZED PERSON OR ENTITY NOR REPRODUCED, TRANSFERRED OR INCORPORATED IN ANY OTHER PROJECT IN ANY MANNER WITHOUT THE EXPRESS WRITTEN CONSENT OF SAMTEC, INC.</p>	<p style="text-align: center;">samtec</p> <p>520 PARK EAST BLVD, NEW ALBANY, IN 47150 PHONE: 812-944-6733 FAX: 812-948-5047 e-Mail info@SAMTEC.com code 55322</p>
<p>SHEET SCALE: 1:1</p>	<p>DESCRIPTION: CUSTOM COM HPC MALE ASSEMBLY</p>
	<p>DWG. NO. ASP-230333-02</p>
	<p>BY: JACK Z 5/11/2023 SHEET 7 OF 8</p>



⊕	0.050 [0.0020]	Z	X	Y
	0.030 [0.0012]	Z	X	Y

COM-HPC® MODULE	"A"
SIZE A	100.000 [3.937]
SIZE B	100.000 [3.937]
SIZE C	100.000 [3.937]
SIZE D	140.000 [5.512]
SIZE E	140.000 [5.512]

FIG 6
COM-HPC® ASSEMBLY APPLICATION
(RECOMMENDED ASP-230333-02 LAYOUT FOR COM-HPC®)

c:\enterprisevault\DWG\MISC\MKTG\ASP-230333-02-MKT.SLDDRW

PROPRIETARY NOTE
THIS DOCUMENT CONTAINS CONFIDENTIAL AND PROPRIETARY INFORMATION AND ALL DESIGN, MANUFACTURING, REPRODUCTION, USE, PATENT RIGHTS AND SALES RIGHTS ARE EXPRESSLY RESERVED BY SAMTEC, INC. THIS DOCUMENT SHALL NOT BE DISCLOSED, IN WHOLE OR PART, TO ANY UNAUTHORIZED PERSON OR ENTITY NOR REPRODUCED, TRANSFERRED OR INCORPORATED IN ANY OTHER PROJECT IN ANY MANNER WITHOUT THE EXPRESS WRITTEN CONSENT OF SAMTEC, INC.

SHEET SCALE: 1:1



520 PARK EAST BLVD, NEW ALBANY, IN 47150
PHONE: 812-944-6733 FAX: 812-948-5047
e-Mail info@SAMTEC.com code 55322

DESCRIPTION:
CUSTOM COM HPC MALE ASSEMBLY

DWG. NO. **ASP-230333-02**

BY: JACK Z 5/11/2023 SHEET 8 OF 8