

DO NOT SCALE FROM THIS PRINT

SOME CENTER FEATURES NOT SHOWN FOR CLARITY

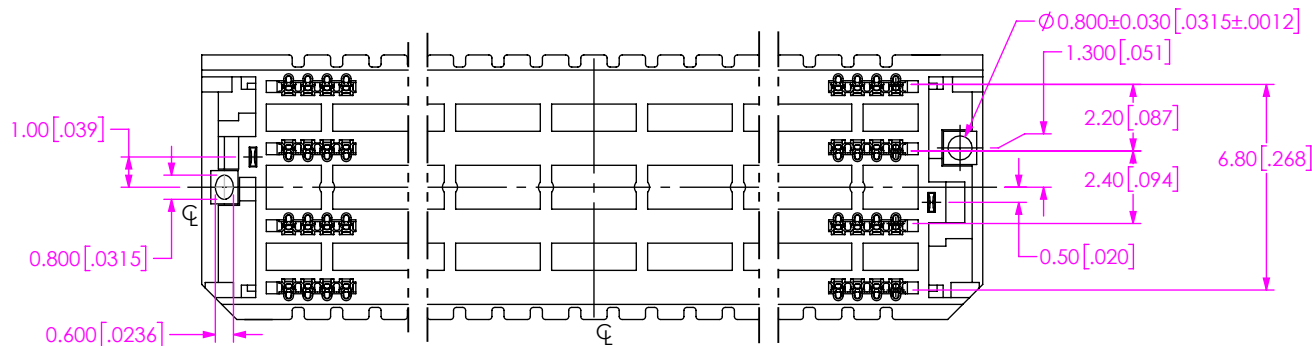
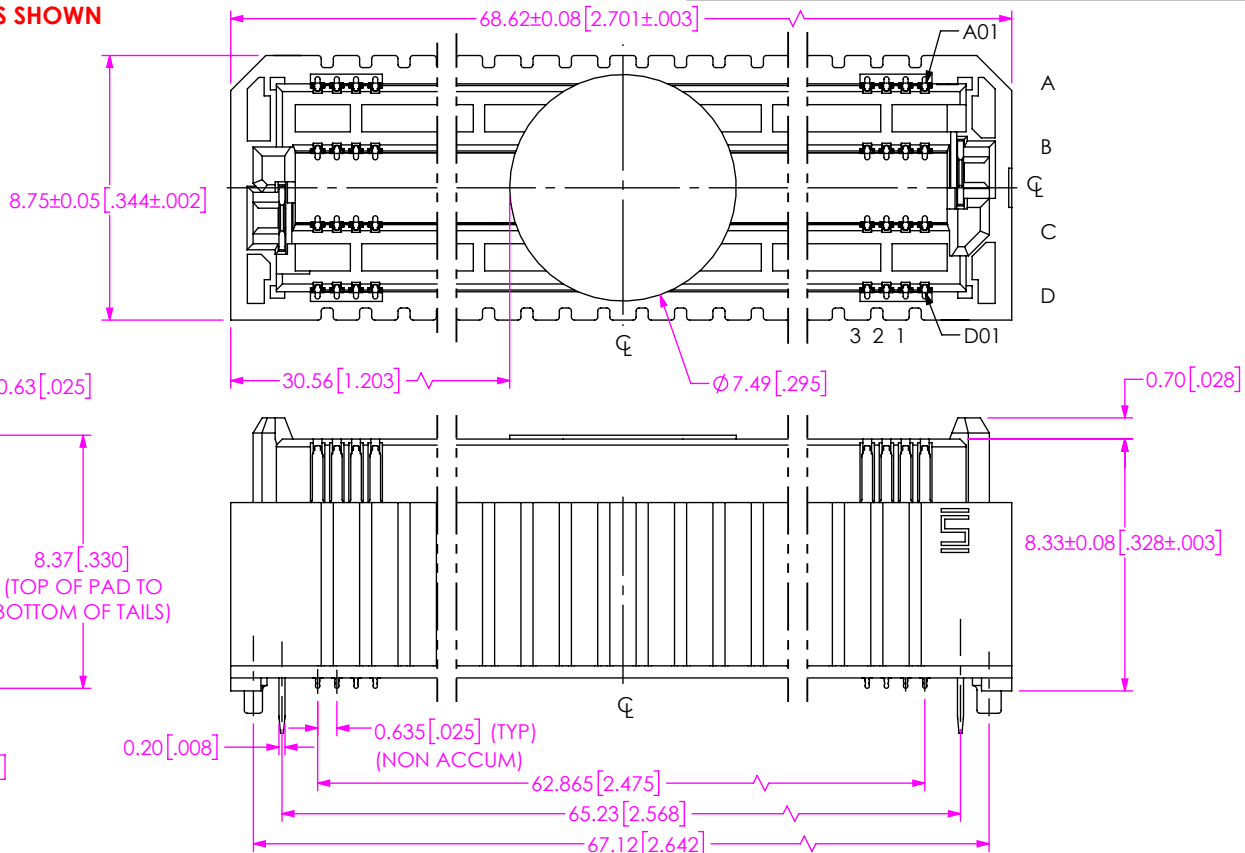
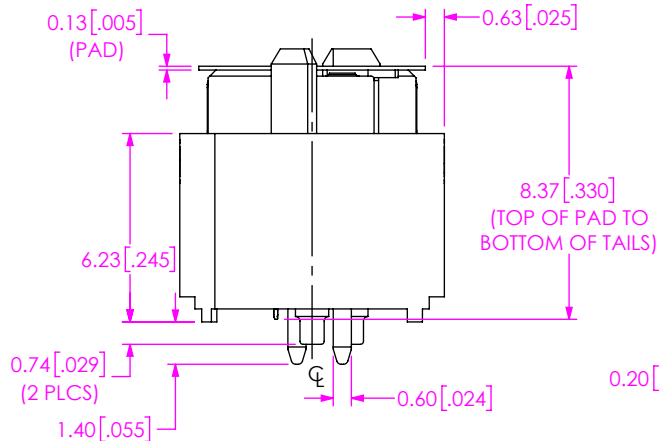
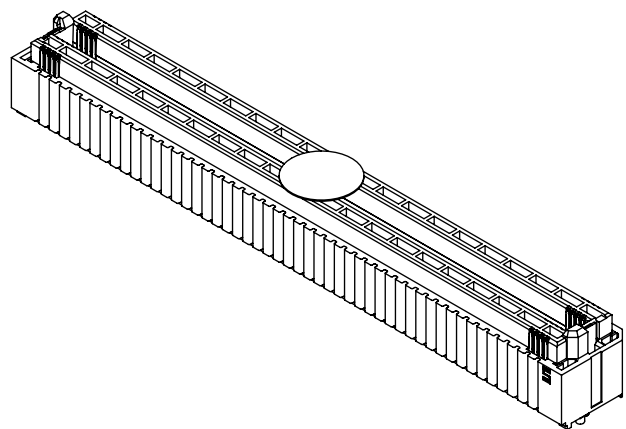

FIG 1  
(ASP-230336-04 SHOWN)

NOTES:

1. MINIMUM PUSHOUT FORCE: 1.2N FOR TERMINAL. MINIMUM RETENTION FORCE 4.45N FOR WELD TAB.
2. PARTS TO BE PACKAGED IN TAPE & REEL.
3. ATTACH LABEL -4X2 TO EACH REEL.
4. ORDERS WILL BE PACKAGED ACCORDING TO THE SAMTEC PACKAGING EFFICIENCY STANDARDS (SPES) FOUND ON WWW.SAMTEC.COM.

c:\enterprise\ault\DWG\MISC\WKTG\ASP-230336-04-MKT.SLDDRW

<p><b>PROPRIETARY NOTE</b></p> <p>THIS DOCUMENT CONTAINS CONFIDENTIAL AND PROPRIETARY INFORMATION AND ALL DESIGN, MANUFACTURING, REPRODUCTION, USE, PATENT RIGHTS AND SALES RIGHTS ARE EXPRESSLY RESERVED BY SAMTEC, INC. THIS DOCUMENT SHALL NOT BE DISCLOSED, IN WHOLE OR PART, TO ANY UNAUTHORIZED PERSON OR ENTITY NOR REPRODUCED, TRANSFERRED OR INCORPORATED IN ANY OTHER PROJECT IN ANY MANNER WITHOUT THE EXPRESS WRITTEN CONSENT OF SAMTEC, INC.</p>		<p>520 PARK EAST BLVD, NEW ALBANY, IN 47150 PHONE: 812-944-6733 FAX: 812-948-5047 e-Mail info@SAMTEC.com code 53322</p>
<p>DO NOT SCALE DRAWING SHEET SCALE: 4:1</p> <p>MATERIAL: INSULATOR: VECTRA 5475, COLOR: NATURAL CONTACT: COPPER ALLOY WELD TAB: COPPER ALLOY</p>	<p>DESCRIPTION: <b>CUSTOM COM HPC MALE ASSEMBLY</b></p> <p>DWG. NO. <b>ASP-230336-04</b></p>	
<p>PLATING: TERMINAL: CONTACT AREA: .000200" REF GOLD REMAINDER: .000200" REF TIN WELD TAB: ENTIRE PIN: .000200" REF TIN</p>		<p>BY: DOLBEARE K 10/26/2023 SHEET 1 OF 8</p>

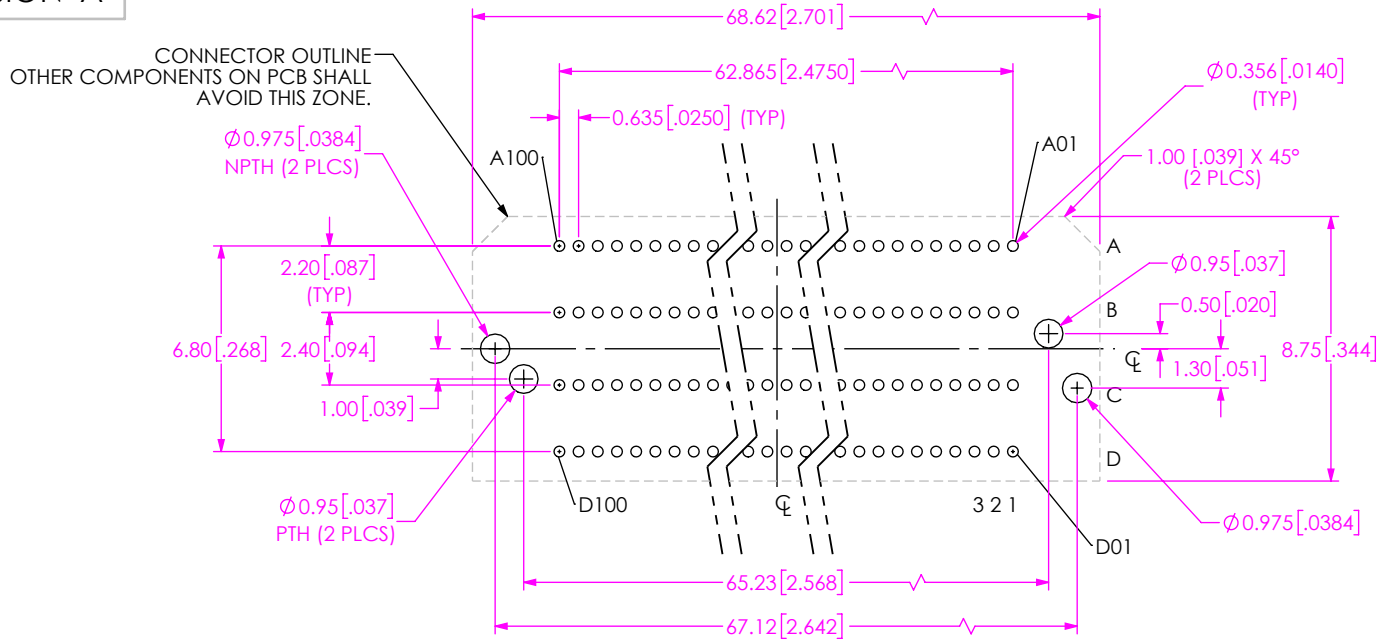

**RECOMMENDED PCB LAYOUT**  
 ALL DIMENSIONS SYMMETRIC ABOUT CENTERLINE  
 (ALL DIMENSIONS FOR REFERENCE ONLY)

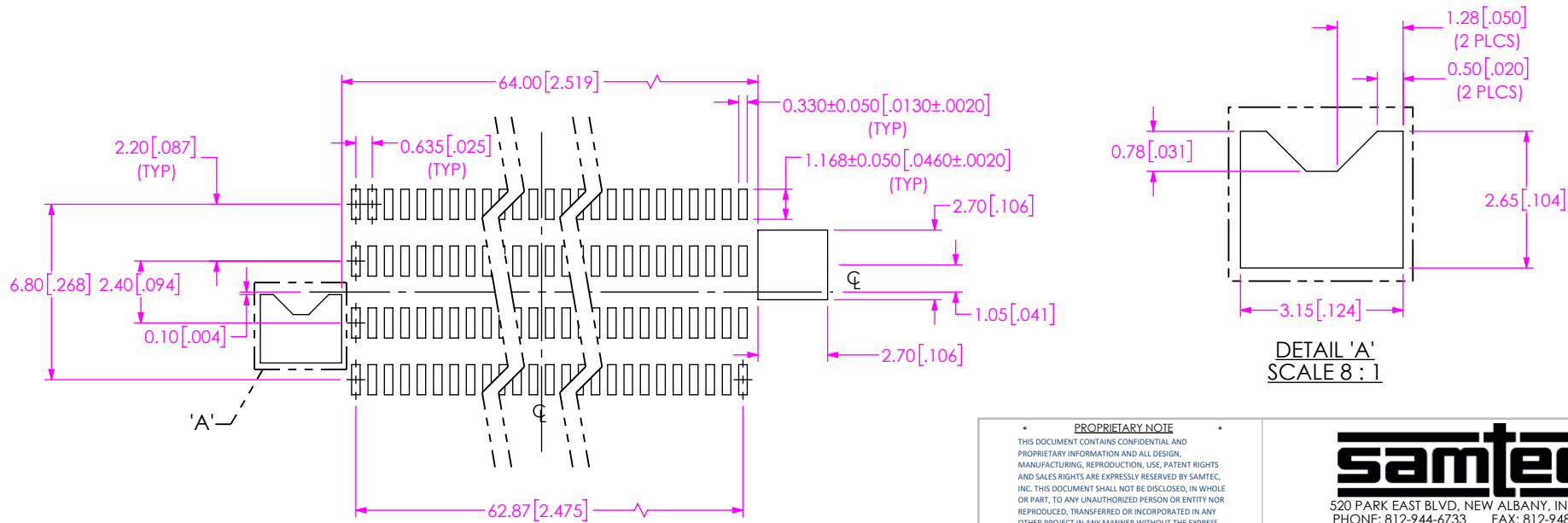

**RECOMMENDED STENCIL LAYOUT**  
 ALL DIMENSIONS SYMMETRIC ABOUT CENTERLINE  
 (STENCIL TO BE 0.125[.0050] THICK)

**DETAIL 'A'**  
 SCALE 8 : 1

**PROPRIETARY NOTE**  
 THIS DOCUMENT CONTAINS CONFIDENTIAL AND PROPRIETARY INFORMATION AND ALL DESIGN, MANUFACTURING, REPRODUCTION, USE, PATENT RIGHTS AND SALES RIGHTS ARE EXPRESSLY RESERVED BY SAMTEC, INC. THIS DOCUMENT SHALL NOT BE DISCLOSED, IN WHOLE OR PART, TO ANY UNAUTHORIZED PERSON OR ENTITY NOR REPRODUCED, TRANSFERRED OR INCORPORATED IN ANY OTHER PROJECT IN ANY MANNER WITHOUT THE EXPRESS WRITTEN CONSENT OF SAMTEC, INC.



520 PARK EAST BLVD, NEW ALBANY, IN 47150  
 PHONE: 812-944-6733 FAX: 812-948-5047  
 e-Mail info@SAMTEC.com code 55322

SHEET SCALE: 2:1

DESCRIPTION:  
 CUSTOM COM HPC MALE ASSEMBLY

DWG. NO.  
**ASP-230336-04**

BY: DOLBEARE K 10/26/2023 SHEET 2 OF 8

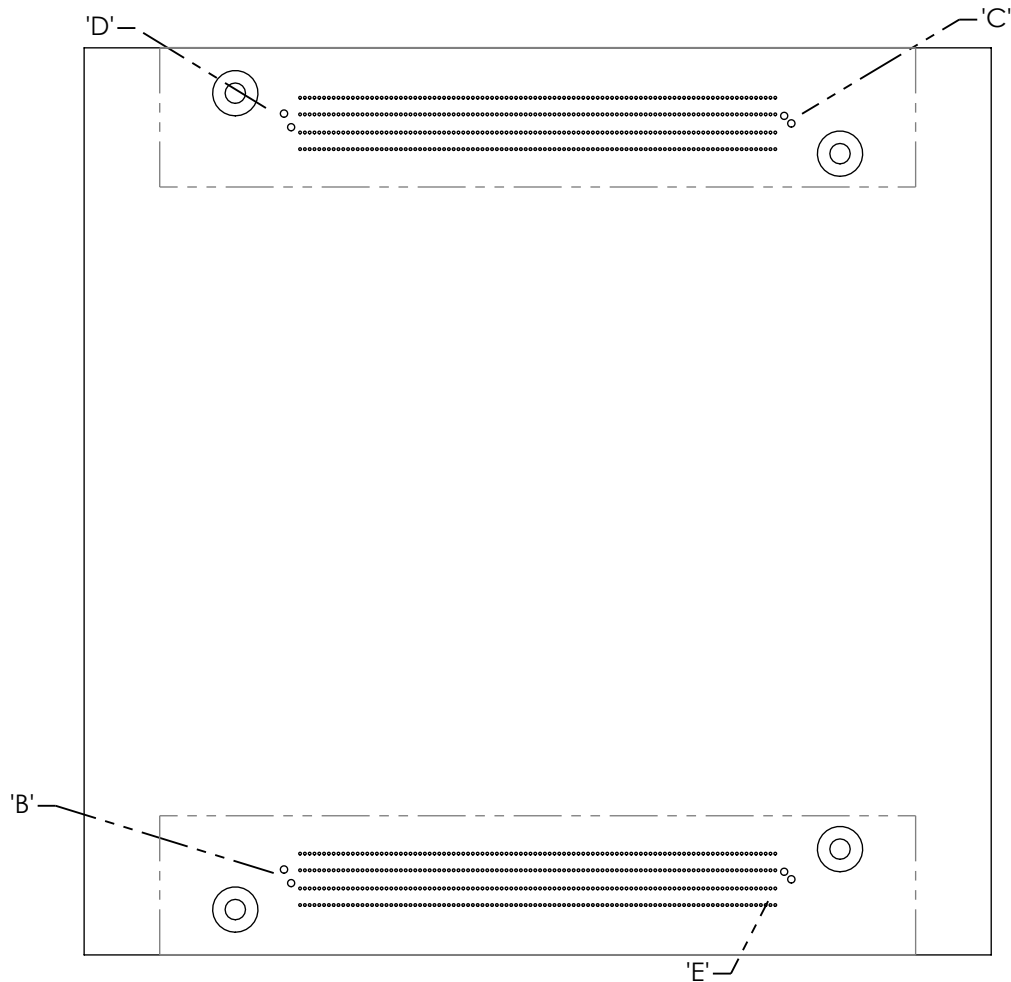

**FIG 2**  
 (RECOMMENDED ASP-230336-04)  
 (LAYOUT FOR COM-HPC® MODULE SIZE A & B)

**PROPRIETARY NOTE**

THIS DOCUMENT CONTAINS CONFIDENTIAL AND PROPRIETARY INFORMATION AND ALL DESIGN, MANUFACTURING, REPRODUCTION, USE, PATENT RIGHTS AND SALES RIGHTS ARE EXPRESSLY RESERVED BY SAMTEC, INC. THIS DOCUMENT SHALL NOT BE DISCLOSED, IN WHOLE OR PART, TO ANY UNAUTHORIZED PERSON OR ENTITY NOR REPRODUCED, TRANSFERRED OR INCORPORATED IN ANY OTHER PROJECT IN ANY MANNER WITHOUT THE EXPRESS WRITTEN CONSENT OF SAMTEC, INC.

SHEET SCALE: 1:1



520 PARK EAST BLVD, NEW ALBANY, IN 47150  
 PHONE: 812-944-6733 FAX: 812-948-5047  
 e-Mail info@SAMTEC.com code 55322

DESCRIPTION:  
 CUSTOM COM HPC MALE ASSEMBLY

DWG. NO. **ASP-230336-04**

BY: DOLBEARE K 10/26/2023 SHEET 3 OF 8

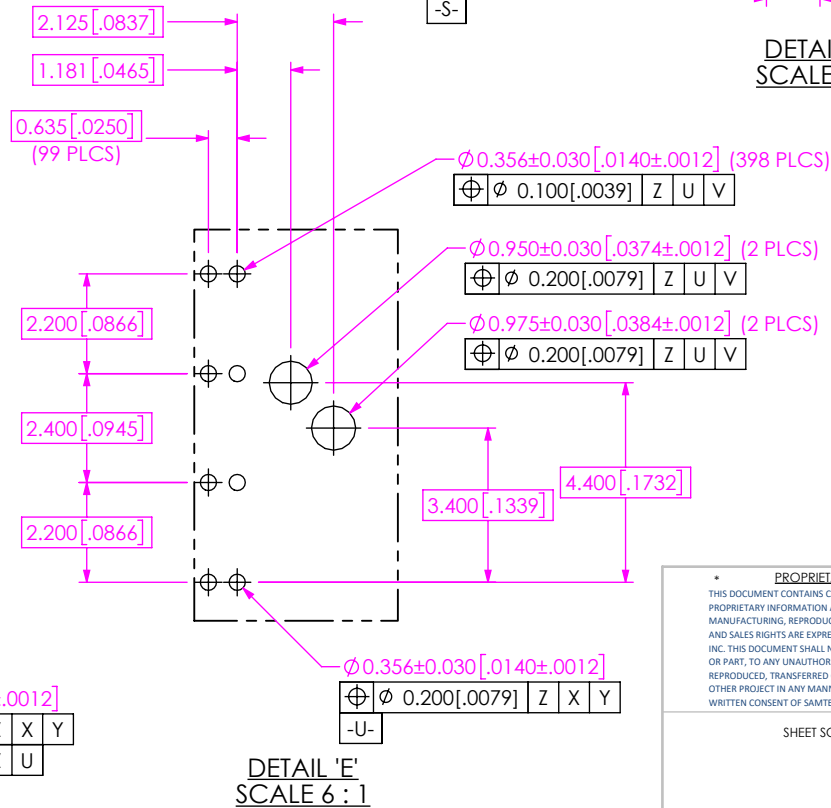
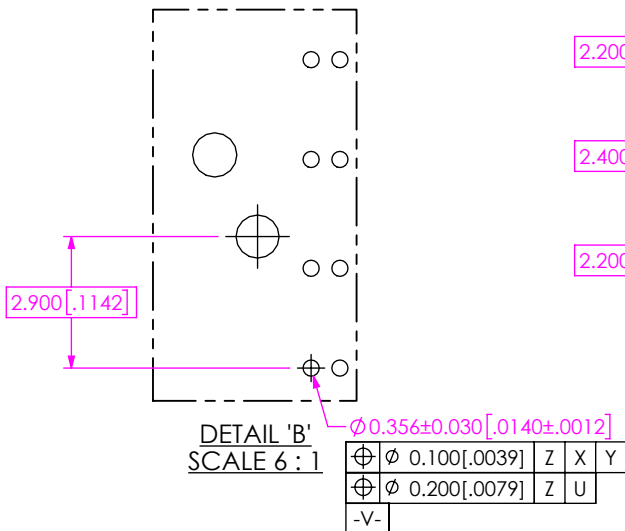
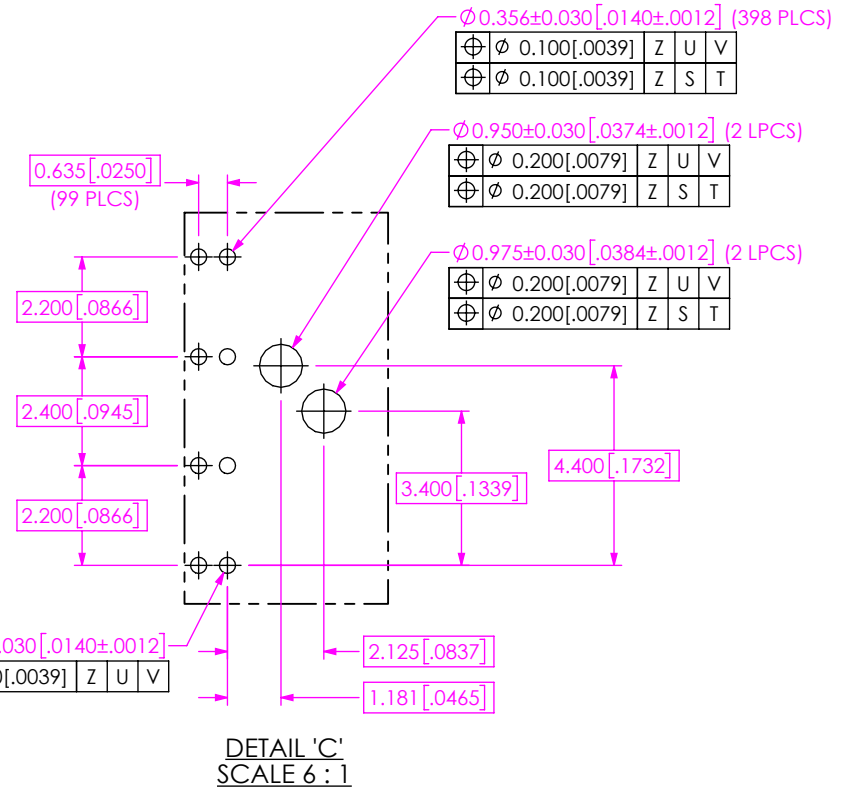
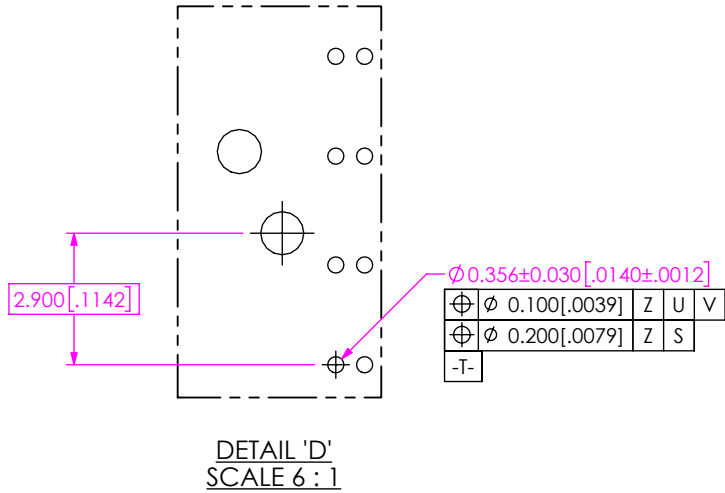

<p>PROPRIETARY NOTE</p> <p>THIS DOCUMENT CONTAINS CONFIDENTIAL AND PROPRIETARY INFORMATION AND ALL DESIGN, MANUFACTURING, REPRODUCTION, USE, PATENT RIGHTS AND SALES RIGHTS ARE EXPRESSLY RESERVED BY SAMTEC, INC. THIS DOCUMENT SHALL NOT BE DISCLOSED, IN WHOLE OR PART, TO ANY UNAUTHORIZED PERSON OR ENTITY NOR REPRODUCED, TRANSFERRED OR INCORPORATED IN ANY OTHER PROJECT IN ANY MANNER WITHOUT THE EXPRESS WRITTEN CONSENT OF SAMTEC, INC.</p>	<p>520 PARK EAST BLVD, NEW ALBANY, IN 47150          PHONE: 812-944-6733 FAX: 812-948-5047          e-Mail info@SAMTEC.com code 55322</p>
	<p>DESCRIPTION:          CUSTOM COM HPC MALE ASSEMBLY</p>
	<p>DWG. NO.          ASP-230336-04</p>
<p>SHEET SCALE: 1:1</p>	<p>BY: DOLBEARE K 10/26/2023 SHEET 4 OF 8</p>

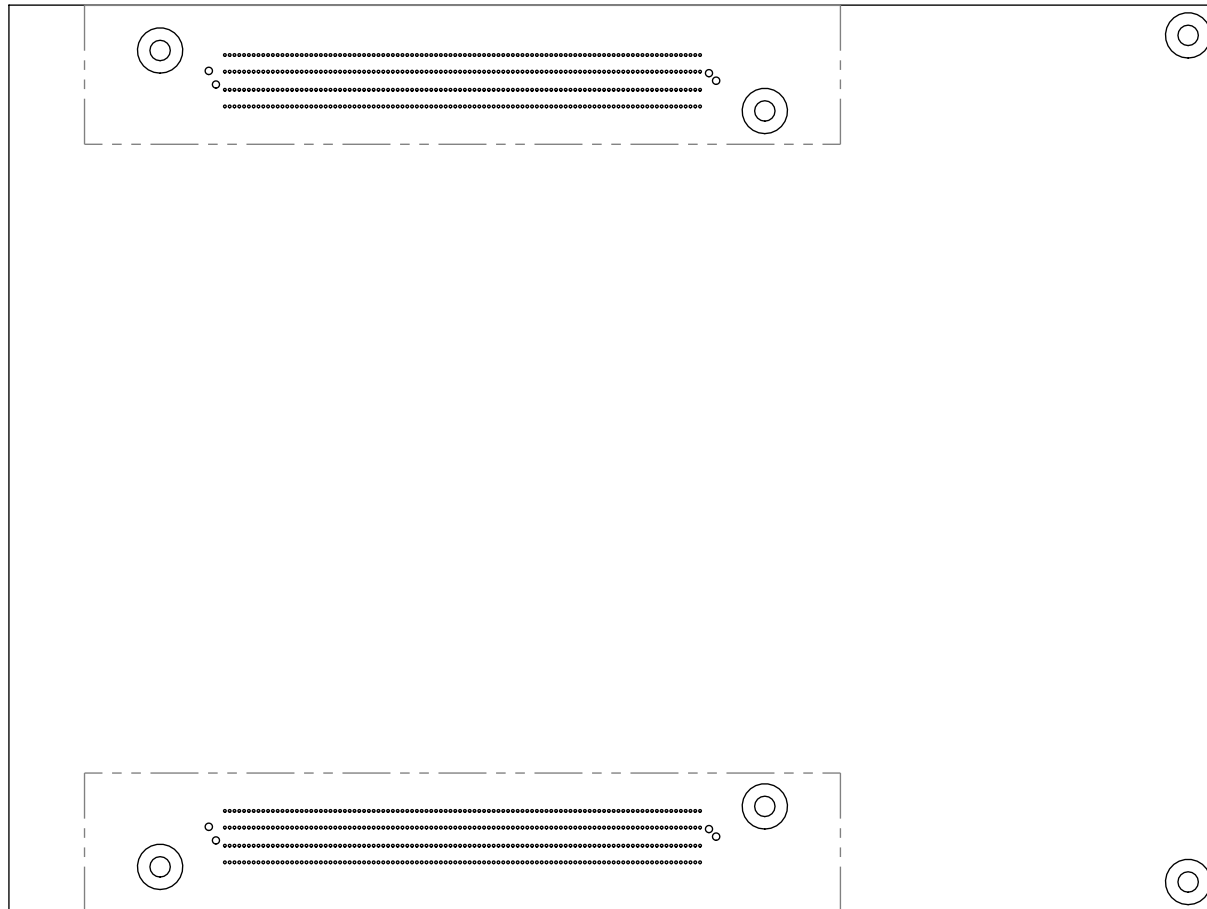

**FIG 3**  
 (RECOMMENDED ASP-230336-04)  
 (SAME AS FIG 2, EXCEPT AS SHOWN)  
 (LAYOUT FOR COM-HPC® MODULE SIZE C)

c:\enterprisevault\DWG\MISC\MKTG\ASP-230336-04-MKT.SLDDRW

**PROPRIETARY NOTE**  
 \* THIS DOCUMENT CONTAINS CONFIDENTIAL AND PROPRIETARY INFORMATION AND ALL DESIGN, MANUFACTURING, REPRODUCTION, USE, PATENT RIGHTS AND SALES RIGHTS ARE EXPRESSLY RESERVED BY SAMTEC, INC. THIS DOCUMENT SHALL NOT BE DISCLOSED, IN WHOLE OR PART, TO ANY UNAUTHORIZED PERSON OR ENTITY NOR REPRODUCED, TRANSFERRED OR INCORPORATED IN ANY OTHER PROJECT IN ANY MANNER WITHOUT THE EXPRESS WRITTEN CONSENT OF SAMTEC, INC. \*

SHEET SCALE: 1:1



520 PARK EAST BLVD, NEW ALBANY, IN 47150  
 PHONE: 812-944-6733 FAX: 812-948-5047  
 e-Mail info@SAMTEC.com code 55322

DESCRIPTION:  
 CUSTOM COM HPC MALE ASSEMBLY

DWG. NO. **ASP-230336-04**

BY: DOLBEARE K 10/26/2023 SHEET 5 OF 8

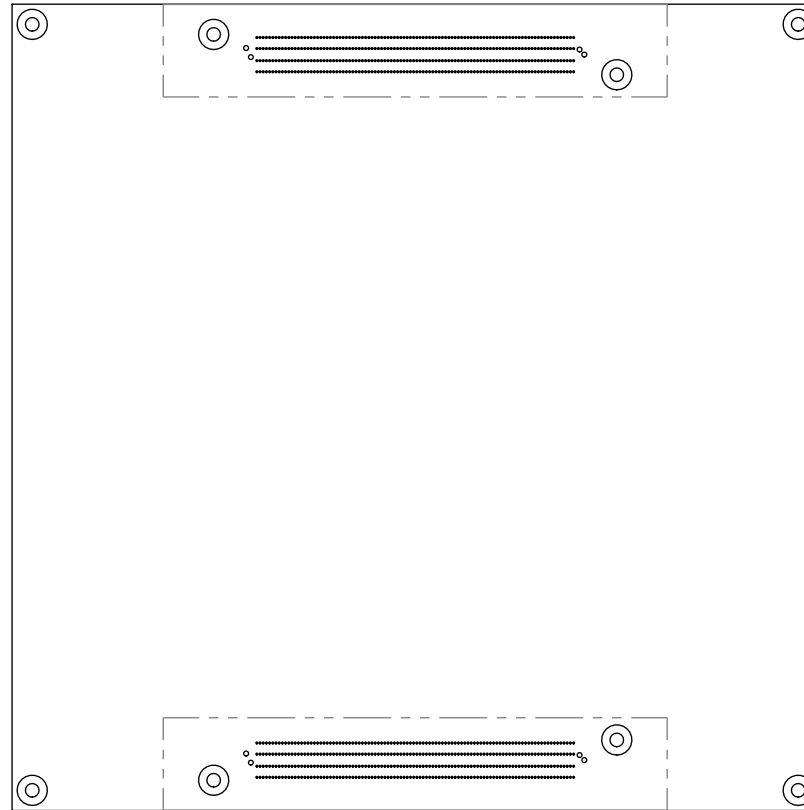

**FIG 4**  
 (RECOMMENDED ASP-230336-04)  
 (SAME AS FIG 2, EXCEPT AS SHOWN)  
 (LAYOUT FOR COM-HPC® MODULE SIZE D)

<p><b>PROPRIETARY NOTE</b></p> <p>THIS DOCUMENT CONTAINS CONFIDENTIAL AND PROPRIETARY INFORMATION AND ALL DESIGN, MANUFACTURING, REPRODUCTION, USE, PATENT RIGHTS AND SALES RIGHTS ARE EXPRESSLY RESERVED BY SAMTEC, INC. THIS DOCUMENT SHALL NOT BE DISCLOSED, IN WHOLE OR PART, TO ANY UNAUTHORIZED PERSON OR ENTITY NOR REPRODUCED, TRANSFERRED OR INCORPORATED IN ANY OTHER PROJECT IN ANY MANNER WITHOUT THE EXPRESS WRITTEN CONSENT OF SAMTEC, INC.</p>	<p><b>samtec</b></p> <p>520 PARK EAST BLVD, NEW ALBANY, IN 47150              PHONE: 812-944-6733 FAX: 812-948-5047              e-Mail info@SAMTEC.com code 55322</p>
<p>SHEET SCALE: 1:1</p>	<p>DESCRIPTION:              CUSTOM COM HPC MALE ASSEMBLY</p>
<p>DWG. NO.</p>	<p><b>ASP-230336-04</b></p>
<p>BY: DOLBEARE K</p>	<p>10/26/2023 SHEET 6 OF 8</p>

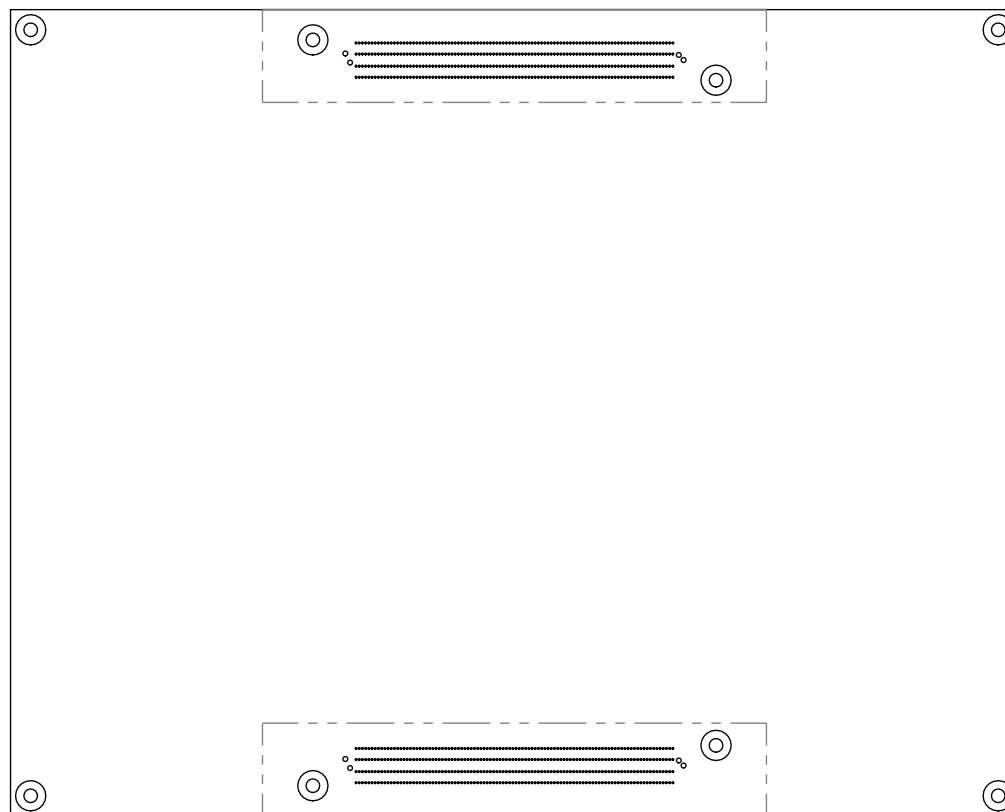
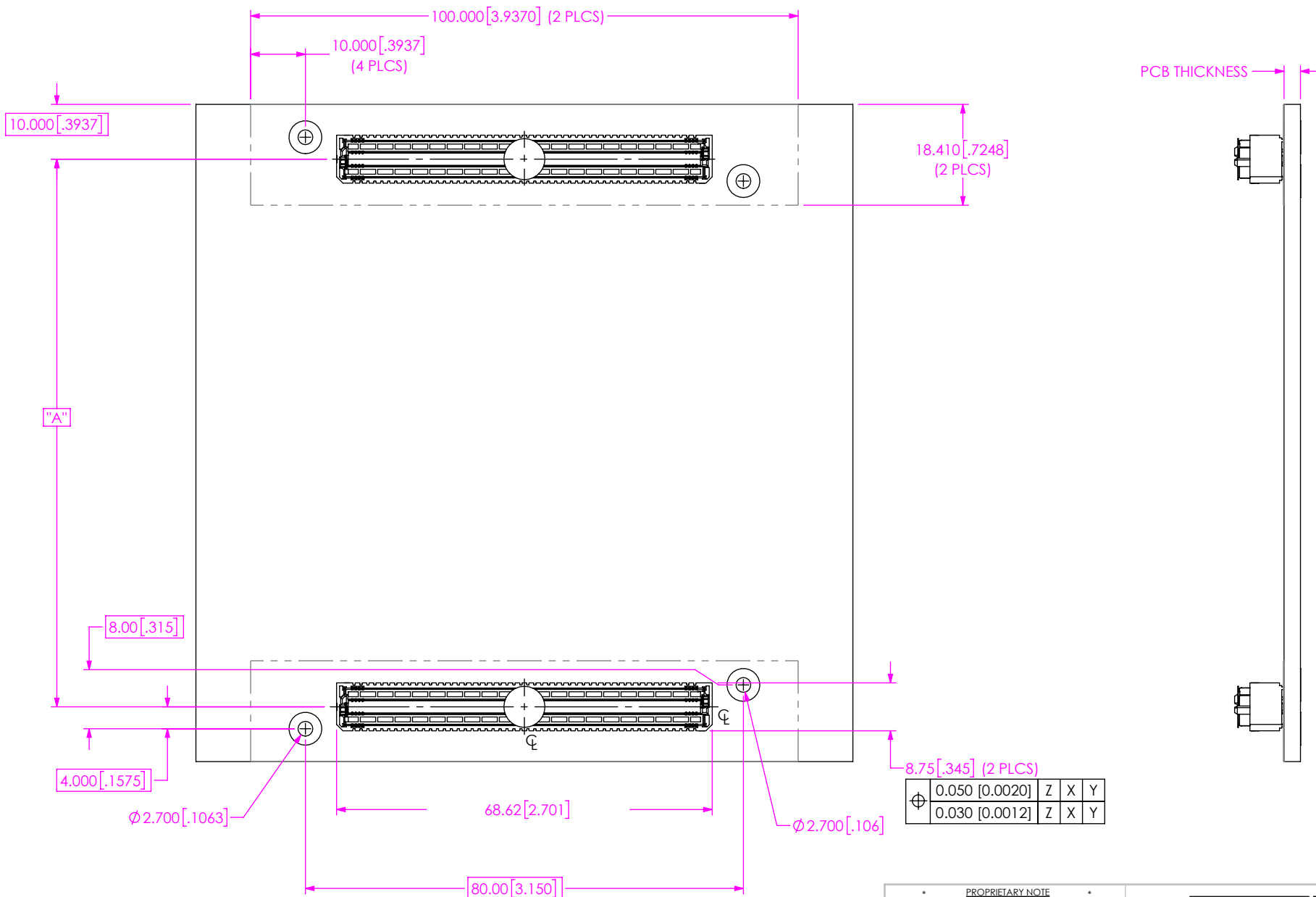

FIG 5  
 (RECOMMENDED ASP-230336-04)  
 (SAME AS FIG 2, EXCEPT AS SHOWN)  
 (LAYOUT FOR COM-HPC® MODULE SIZE E)

c:\enterprisevault\DWG\MISC\MKTG\ASP-230336-04-MKT.SLDDRW

<p style="text-align: center;">* PROPRIETARY NOTE *</p> <p>THIS DOCUMENT CONTAINS CONFIDENTIAL AND PROPRIETARY INFORMATION AND ALL DESIGN, MANUFACTURING, REPRODUCTION, USE, PATENT RIGHTS AND SALES RIGHTS ARE EXPRESSLY RESERVED BY SAMTEC, INC. THIS DOCUMENT SHALL NOT BE DISCLOSED, IN WHOLE OR PART, TO ANY UNAUTHORIZED PERSON OR ENTITY NOR REPRODUCED, TRANSFERRED OR INCORPORATED IN ANY OTHER PROJECT IN ANY MANNER WITHOUT THE EXPRESS WRITTEN CONSENT OF SAMTEC, INC.</p>	<p style="text-align: center;"><b>samtec</b></p> <p>520 PARK EAST BLVD, NEW ALBANY, IN 47150              PHONE: 812-944-6733 FAX: 812-948-5047              e-Mail info@SAMTEC.com code 55322</p>
<p>SHEET SCALE: 1:1</p>	<p>DESCRIPTION:              CUSTOM COM HPC MALE ASSEMBLY</p>
	<p>DWG. NO. <b>ASP-230336-04</b></p> <p>BY: DOLBEARE K 10/26/2023 SHEET 7 OF 8</p>



$\oplus$	0.050 [0.0020]	Z	X	Y
$\oplus$	0.030 [0.0012]	Z	X	Y

General Table	
TABLE 1	
COM-HPC® MODULE	"A"
SIZE A	100.000 [3.937]
SIZE B	100.000 [3.937]
SIZE C	100.000 [3.937]
SIZE D	140.000 [5.512]
SIZE E	140.000 [5.512]

**FIG 6**  
COM-HPC® ASSEMBLY APPLICATION  
(RECOMMENDED ASP-230336-04 LAYOUT FOR COM-HPC®)

**PROPRIETARY NOTE**  
THIS DOCUMENT CONTAINS CONFIDENTIAL AND PROPRIETARY INFORMATION AND ALL DESIGN, MANUFACTURING, REPRODUCTION, USE, PATENT RIGHTS AND SALES RIGHTS ARE EXPRESSLY RESERVED BY SAMTEC, INC. THIS DOCUMENT SHALL NOT BE DISCLOSED, IN WHOLE OR PART, TO ANY UNAUTHORIZED PERSON OR ENTITY NOR REPRODUCED, TRANSFERRED OR INCORPORATED IN ANY OTHER PROJECT IN ANY MANNER WITHOUT THE EXPRESS WRITTEN CONSENT OF SAMTEC, INC.

SHEET SCALE: 1:1

**samtec**  
520 PARK EAST BLVD, NEW ALBANY, IN 47150  
PHONE: 812-944-6733 FAX: 812-948-5047  
e-Mail info@SAMTEC.com code 55322

DESCRIPTION:  
CUSTOM COM HPC MALE ASSEMBLY

DWG. NO.  
**ASP-230336-04**

BY: DOLBEARE K 10/26/2023 SHEET 8 OF 8