

DO NOT  
SCALE FROM  
THIS PRINT

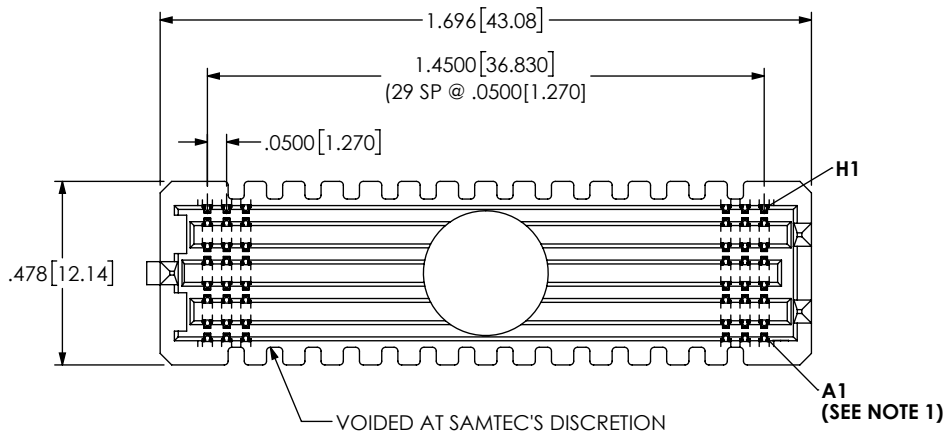

SOME CENTER FEATURES NOT  
SHOWN FOR CLARITY

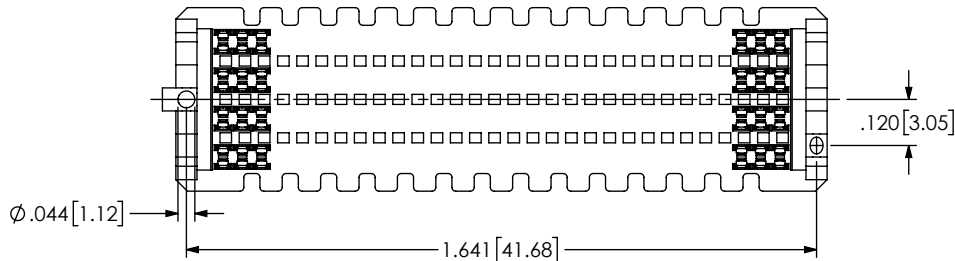
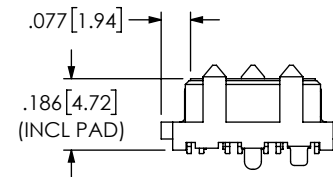
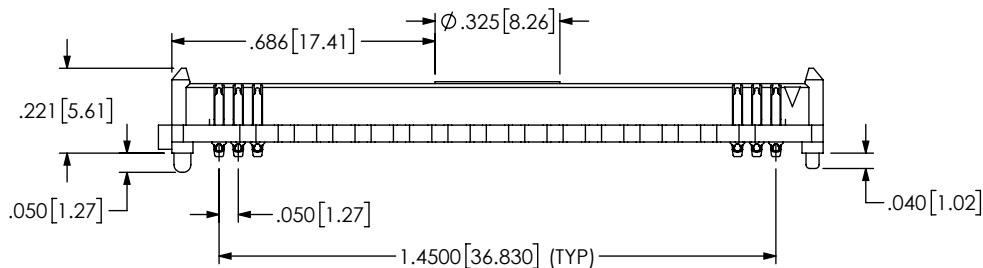

NOTES:

- ANSI/VITA 90 VNX+ INDUSTRY STANDARD COMPLIANT CONNECTOR FOR VNX+ APPLICATIONS.  
ATTENTION: CUSTOMIZED A1 PIN LOCATION FOR V90 APPLICATIONS.  
IMPORTANT: PCB LAYOUT ON SHEET 3 MUST BE USED FOR V90 COMPLIANCE.
- MINIMUM PUSHOUT FORCE: 0.50 LBS.
- PARTS TO BE PACKAGED IN TAPE AND REEL.
- ORDERS WILL BE PACKAGED ACCORDING TO THE SAMTEC PACKAGING EFFICIENCY STANDARDS (SPES) FOUND ON WWW.SAMTEC.COM.

c:\enterprise\vaull\DWG\MISC\MKTG\ASP-232970-01-MKT.SLDDRW

<p><b>PROPRIETARY NOTE</b></p> <p>THIS DOCUMENT CONTAINS CONFIDENTIAL AND PROPRIETARY INFORMATION AND ALL DESIGN, MANUFACTURING, REPRODUCTION, USE, PATENT RIGHTS AND SALES RIGHTS ARE EXPRESSLY RESERVED BY SAMTEC, INC. THIS DOCUMENT SHALL NOT BE DISCLOSED, IN WHOLE OR PART, TO ANY UNAUTHORIZED PERSON OR ENTITY NOR REPRODUCED, TRANSFERRED OR INCORPORATED IN ANY OTHER PROJECT IN ANY MANNER WITHOUT THE EXPRESS WRITTEN CONSENT OF SAMTEC, INC.</p>	 <p>520 PARK EAST BLVD, NEW ALBANY, IN 47150 PHONE: 812-944-6733 FAX: 812-948-5047 e-Mail: info@SAMTEC.com code 55322</p>
<p>DO NOT SCALE DRAWING SHEET SCALE: 2:1 <b>INSULATOR: LCP, COLOR: BLACK</b> TERMINAL: COPPER ALLOY PLATING: CONTACT AREA: .000030 GOLD REMAINDER: .000200 TIN/LEAD (90/10) LEADED SOLDER</p>	<p>DESCRIPTION: VITA 90 SEAM 240 PIN (LEADED SOLDER)</p> <p>DWG. NO. <b>ASP-232970-01</b></p> <p>BY: J. BROWNING 08/22/2023 SHEET 1 OF 4</p>

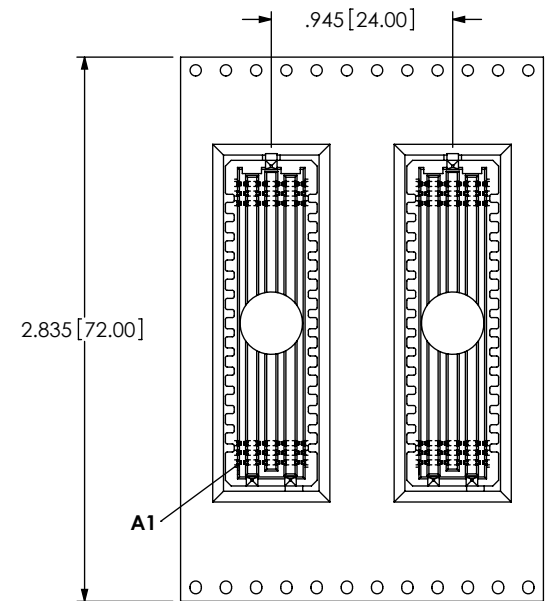

USER DIRECTION OF UN-REELING →  
POCKET NOT DETAILED

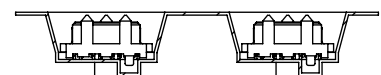

PACKAGING VIEW

**PROPRIETARY NOTE**  
 THIS DOCUMENT CONTAINS CONFIDENTIAL AND PROPRIETARY INFORMATION AND ALL DESIGN, MANUFACTURING, REPRODUCTION, USE, PATENT RIGHTS AND SALES RIGHTS ARE EXPRESSLY RESERVED BY SAMTEC, INC. THIS DOCUMENT SHALL NOT BE DISCLOSED, IN WHOLE OR PART, TO ANY UNAUTHORIZED PERSON OR ENTITY NOR REPRODUCED, TRANSFERRED OR INCORPORATED IN ANY OTHER PROJECT IN ANY MANNER WITHOUT THE EXPRESS WRITTEN CONSENT OF SAMTEC, INC.

**samtec**  
 520 PARK EAST BLVD., NEW ALBANY, IN 47150  
 PHONE: 812-944-6733 FAX: 812-948-5047  
 e-Mail info@SAMTEC.com code 55322

SHEET SCALE: 3:1

DESCRIPTION:  
 VITA 90 SEAM 240 PIN (LEADED SOLDER)

DWG. NO. ASP-232970-01

BY: J. BROWNING 08/22/2023 SHEET 2 OF 4

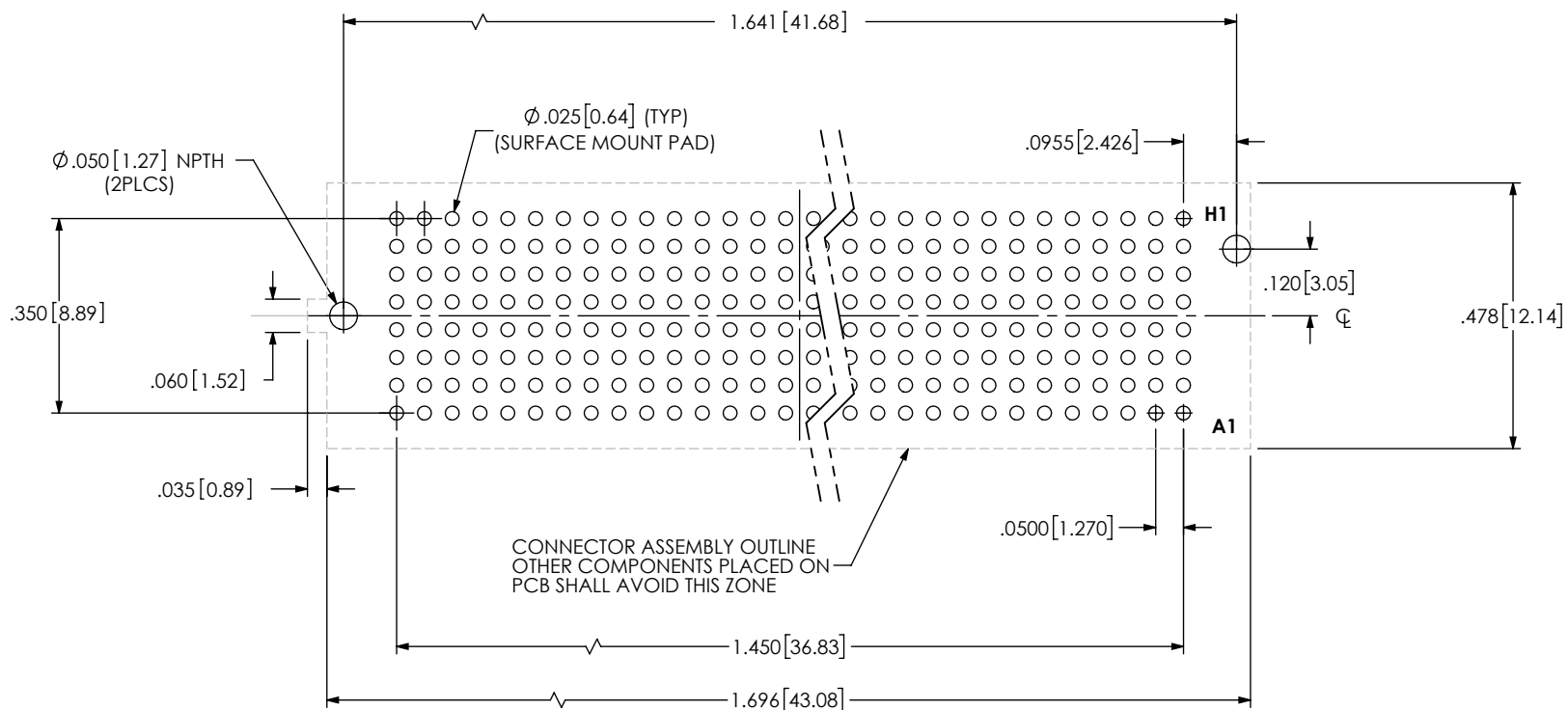

RECOMMENDED PCB LAYOUT  
ALL DIMENSIONS SYMMETRIC ABOUT CENTERLINE

PROPRIETARY NOTE

THIS DOCUMENT CONTAINS CONFIDENTIAL AND PROPRIETARY INFORMATION AND ALL DESIGN, MANUFACTURING, REPRODUCTION, USE, PATENT RIGHTS AND SALES RIGHTS ARE EXPRESSLY RESERVED BY SAMTEC, INC. THIS DOCUMENT SHALL NOT BE DISCLOSED, IN WHOLE OR PART, TO ANY UNAUTHORIZED PERSON OR ENTITY NOR REPRODUCED, TRANSFERRED OR INCORPORATED IN ANY OTHER PROJECT IN ANY MANNER WITHOUT THE EXPRESS WRITTEN CONSENT OF SAMTEC, INC.



520 PARK EAST BLVD., NEW ALBANY, IN 47150  
PHONE: 812-944-6733 FAX: 812-948-5047  
e-Mail info@SAMTEC.com code 55322

SHEET SCALE: 3:1

DESCRIPTION:  
VITA 90 SEAM 240 PIN (LEADED SOLDER)

DWG. NO.  
ASP-232970-01

BY: J. BROWNING 08/22/2023 SHEET 3 OF 4

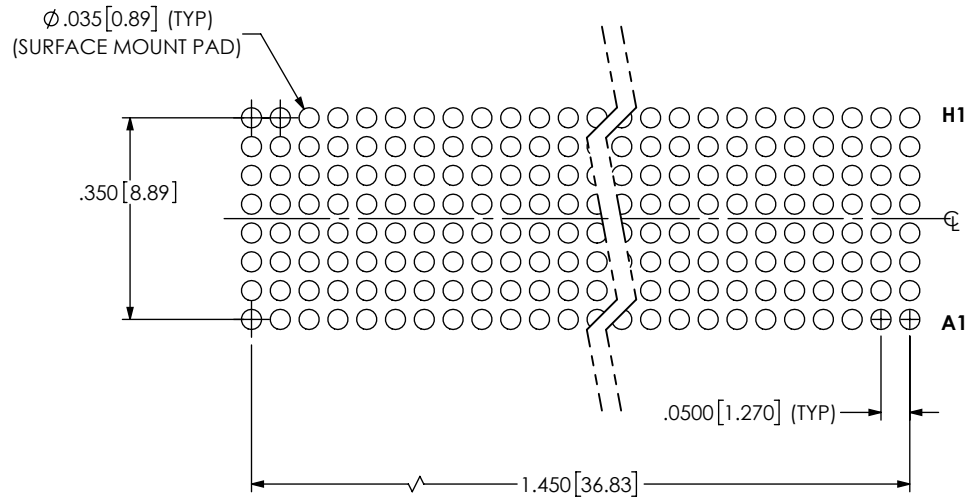

**RECOMMENDED STENCIL LAYOUT**  
 ALL DIMENSIONS SYMMETRIC ABOUT CENTERLINE  
 STENCIL TO BE .0060 THICK

\* PROPRIETARY NOTE \*  
 THIS DOCUMENT CONTAINS CONFIDENTIAL AND PROPRIETARY INFORMATION AND ALL DESIGN, MANUFACTURING, REPRODUCTION, USE, PATENT RIGHTS AND SALES RIGHTS ARE EXPRESSLY RESERVED BY SAMTEC, INC. THIS DOCUMENT SHALL NOT BE DISCLOSED, IN WHOLE OR PART, TO ANY UNAUTHORIZED PERSON OR ENTITY NOR REPRODUCED, TRANSFERRED OR INCORPORATED IN ANY OTHER PROJECT IN ANY MANNER WITHOUT THE EXPRESS WRITTEN CONSENT OF SAMTEC, INC.

**samtec**  
 520 PARK EAST BLVD., NEW ALBANY, IN 47150  
 PHONE: 812-944-6733 FAX: 812-948-5047  
 e-Mail info@SAMTEC.com code 55322

SHEET SCALE: 3:1

DESCRIPTION:  
 VITA 90 SEAM 240 PIN (LEADED SOLDER)

DWG. NO. ASP-232970-01

BY: J. BROWNING 08/22/2023 SHEET 4 OF 4