

DESIGNED AND DIMENSIONED IN INCHES[MILLIMETERS]
ALL DIMENSIONS REFERENCE EXCEPT AS SHOWN

DO NOT
SCALE FROM
THIS PRINT

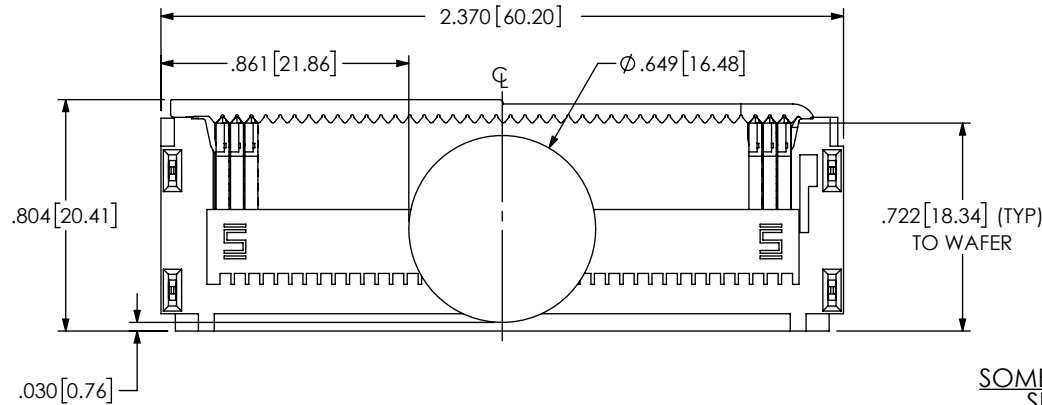

SOME CENTER FEATURES NOT
SHOWN FOR CLARITY

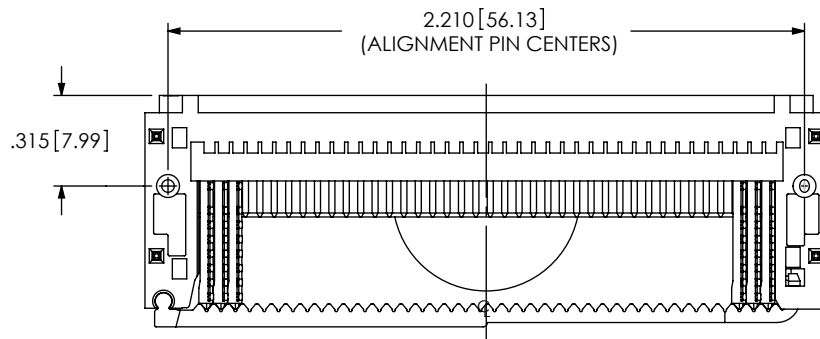
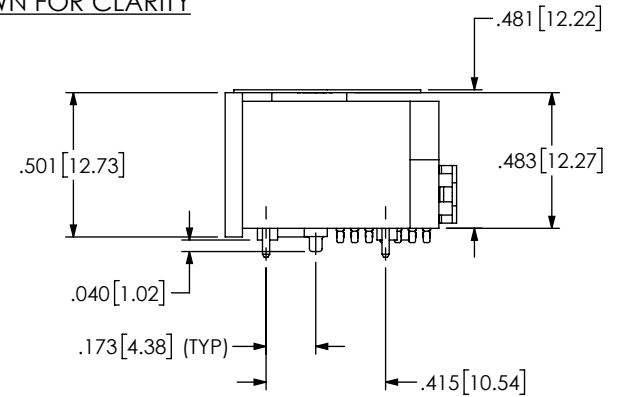
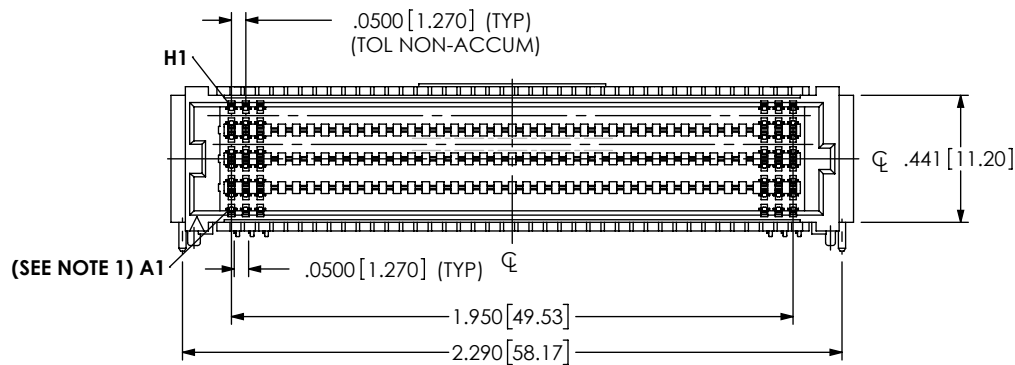

NOTES:

- ANSI/VITA 90 VNX+ INDUSTRY STANDARD COMPLIANT CONNECTOR FOR VNX+ APPLICATIONS.
ATTENTION: CUSTOMIZED A1 PIN LOCATION FOR V90 APPLICATIONS.
IMPORTANT: PCB LAYOUT ON SHEET 3 MUST BE USED FOR V90 COMPLIANCE.
- MINIMUM PUSHOUT FORCE: 0.50 LBS.
- PARTS TO BE PACKAGED IN TAPE AND REEL.
- ORDERS WILL BE PACKAGED ACCORDING TO THE SAMTEC PACKAGING EFFICIENCY STANDARDS (SPES) FOUND ON WWW.SAMTEC.COM.

PROPRIETARY NOTE

THIS DOCUMENT CONTAINS CONFIDENTIAL AND PROPRIETARY INFORMATION AND ALL DESIGN, MANUFACTURING, REPRODUCTION, USE, PATENT RIGHTS AND SALES RIGHTS ARE EXPRESSLY RESERVED BY SAMTEC, INC. THIS DOCUMENT SHALL NOT BE DISCLOSED, IN WHOLE OR PART, TO ANY UNAUTHORIZED PERSON OR ENTITY NOR REPRODUCED, TRANSFERRED OR INCORPORATED IN ANY OTHER PROJECT IN ANY MANNER WITHOUT THE EXPRESS WRITTEN CONSENT OF SAMTEC, INC.

DO NOT SCALE DRAWING
SHEET SCALE: 3:2

MATERIAL:
INSULATOR: LCP, COLOR: BLACK
CONTACT: COPPER ALLOY
PLATING:
CONTACT AREA: .000030 GOLD
REMAINDER: .000200 TIN
LEAD FREE SOLDER



520 PARK EAST BLVD., NEW ALBANY, IN 47150
PHONE: 812-944-6733 FAX: 812-948-5047
e-Mail info@SAMTEC.com code 55322

DESCRIPTION: VITA 90 SEAF-RA 320 PIN (LEAD FREE)

DWG. NO. ASP-232973-02

BY: J. BROWNING 07/20/2023 SHEET 1 OF 4

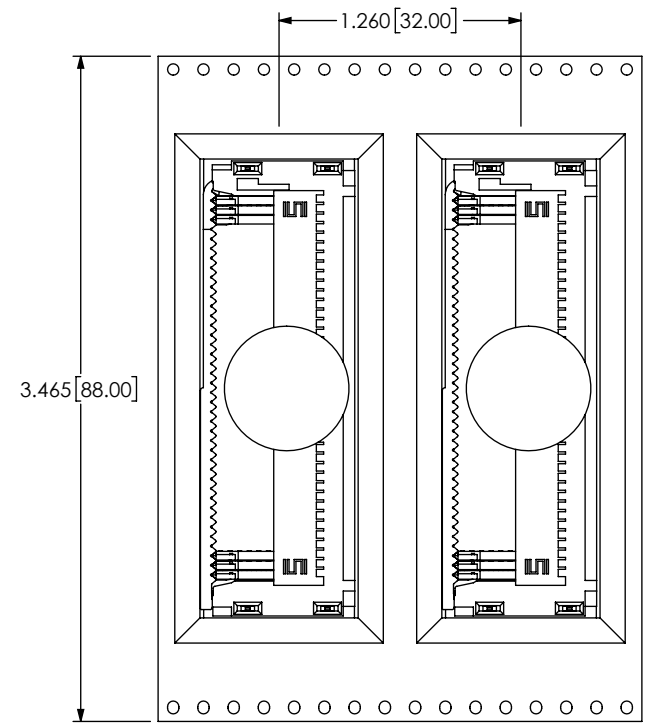
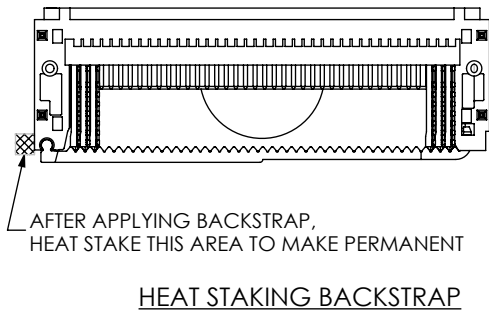
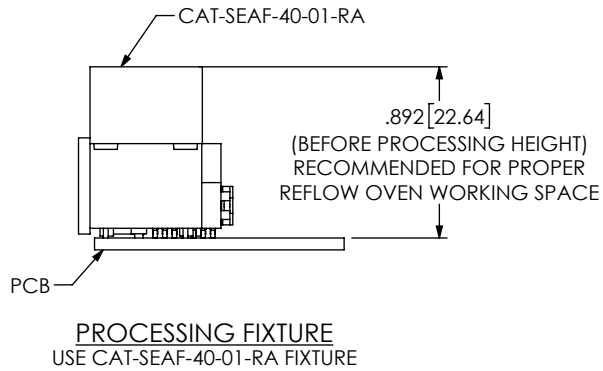

USER DIRECTION OF UN-REELING →
POCKET NOT DETAILED

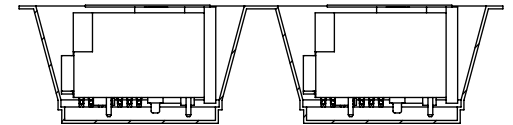

PACKAGING VIEW

PROPRIETARY NOTE

THIS DOCUMENT CONTAINS CONFIDENTIAL AND PROPRIETARY INFORMATION AND ALL DESIGN, MANUFACTURING, REPRODUCTION, USE, PATENT RIGHTS AND SALES RIGHTS ARE EXPRESSLY RESERVED BY SAMTEC, INC. THIS DOCUMENT SHALL NOT BE DISCLOSED, IN WHOLE OR PART, TO ANY UNAUTHORIZED PERSON OR ENTITY NOR REPRODUCED, TRANSFERRED OR INCORPORATED IN ANY OTHER PROJECT IN ANY MANNER WITHOUT THE EXPRESS WRITTEN CONSENT OF SAMTEC, INC.



520 PARK EAST BLVD, NEW ALBANY, IN 47150
PHONE: 812-944-6733 FAX: 812-948-5047
e-Mail info@SAMTEC.com code 55322

SHEET SCALE: 1:2

DESCRIPTION:
VITA 90 SEAF-RA 320 PIN (LEAD FREE)

DWG. NO.
ASP-232973-02

BY: J. BROWNING 07/20/2023 SHEET 2 OF 4

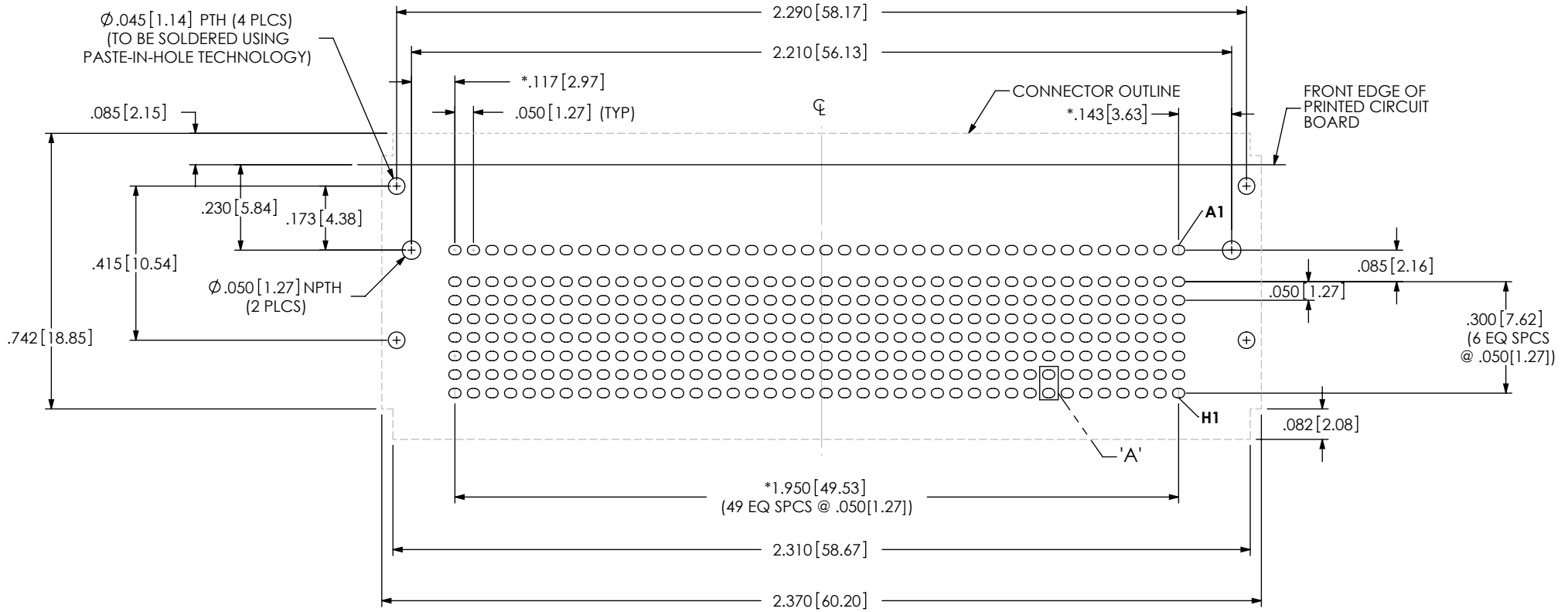

RECOMMENDED PCB LAYOUT
 ALL DIMENSIONS ARE SYMMETRIC ABOUT THE CENTERLINE EXCEPT "*" DIMENSIONS)

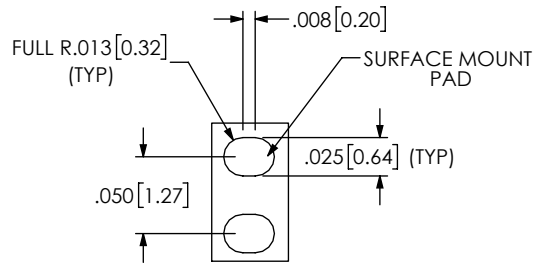

DETAIL 'A'
 SCALE 8 : 1

<p>PROPRIETARY NOTE</p> <p>THIS DOCUMENT CONTAINS CONFIDENTIAL AND PROPRIETARY INFORMATION AND ALL DESIGN, MANUFACTURING, REPRODUCTION, USE, PATENT RIGHTS AND SALES RIGHTS ARE EXPRESSLY RESERVED BY SAMTEC, INC. THIS DOCUMENT SHALL NOT BE DISCLOSED, IN WHOLE OR PART, TO ANY UNAUTHORIZED PERSON OR ENTITY NOR REPRODUCED, TRANSFERRED OR INCORPORATED IN ANY OTHER PROJECT IN ANY MANNER WITHOUT THE EXPRESS WRITTEN CONSENT OF SAMTEC, INC.</p>	<p>samtec</p> <p>520 PARK EAST BLVD, NEW ALBANY, IN 47150 PHONE: 812-944-6733 FAX: 812-948-5047 e-Mail info@SAMTEC.com code 55322</p>	
	<p>DESCRIPTION: VITA 90 SEAF-RA 320 PIN (LEAD FREE)</p>	
	<p>DWG. NO. ASP-232973-02</p>	
<p>SHEET SCALE: 2.5:1</p>		<p>BY: J. BROWNING 07/20/2023 SHEET 3 OF 4</p>

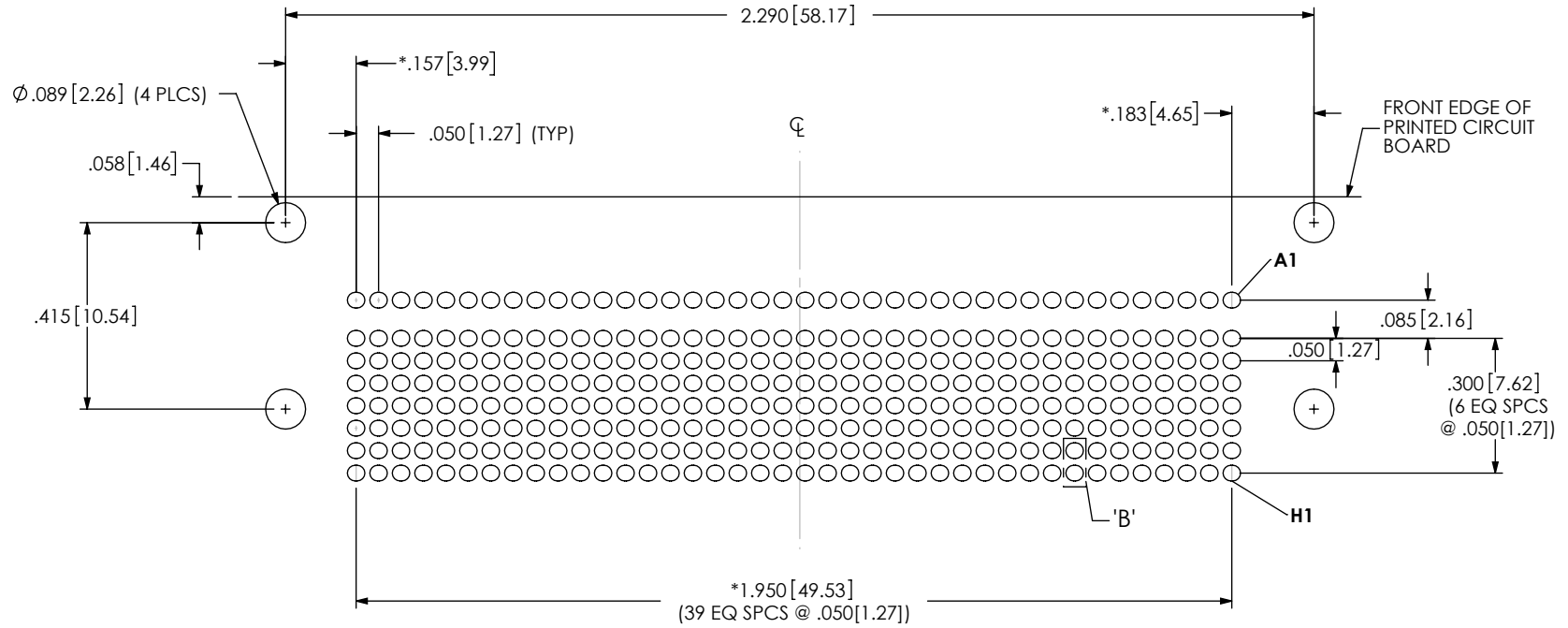

RECOMMENDED STENCIL LAYOUT
 ALL DIMENSIONS ARE SYMMETRIC ABOUT THE CENTERLINE EXCEPT "*" DIMENSIONS
 STENCIL TO BE .0060 THICK

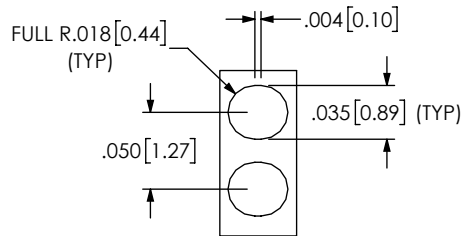

DETAIL 'B'
 SCALE 8 : 1

<p>PROPRIETARY NOTE</p> <p>THIS DOCUMENT CONTAINS CONFIDENTIAL AND PROPRIETARY INFORMATION AND ALL DESIGN, MANUFACTURING, REPRODUCTION, USE, PATENT RIGHTS AND SALES RIGHTS ARE EXPRESSLY RESERVED BY SAMTEC, INC. THIS DOCUMENT SHALL NOT BE DISCLOSED, IN WHOLE OR PART, TO ANY UNAUTHORIZED PERSON OR ENTITY NOR REPRODUCED, TRANSFERRED OR INCORPORATED IN ANY OTHER PROJECT IN ANY MANNER WITHOUT THE EXPRESS WRITTEN CONSENT OF SAMTEC, INC.</p>	<p>samtec</p> <p>520 PARK EAST BLVD, NEW ALBANY, IN 47150 PHONE: 812-944-6733 FAX: 812-948-5047 e-Mail info@SAMTEC.com code 55322</p>	
	<p>DESCRIPTION: VITA 90 SEAF-RA 320 PIN (LEAD FREE)</p>	
	<p>DWG. NO. ASP-232973-02</p>	
<p>SHEET SCALE: 2.5:1</p>		<p>BY: J. BROWNING 07/20/2023 SHEET 4 OF 4</p>