

DO NOT
SCALE FROM
THIS PRINT

ASP-240411-XX

OPTION
-01: 10µ" SELECTIVE GOLD IN CONTACT AREA, MATTE TIN ON TAIL
-02: 30µ" SELECTIVE GOLD IN CONTACT AREA, MATTE TIN ON TAIL

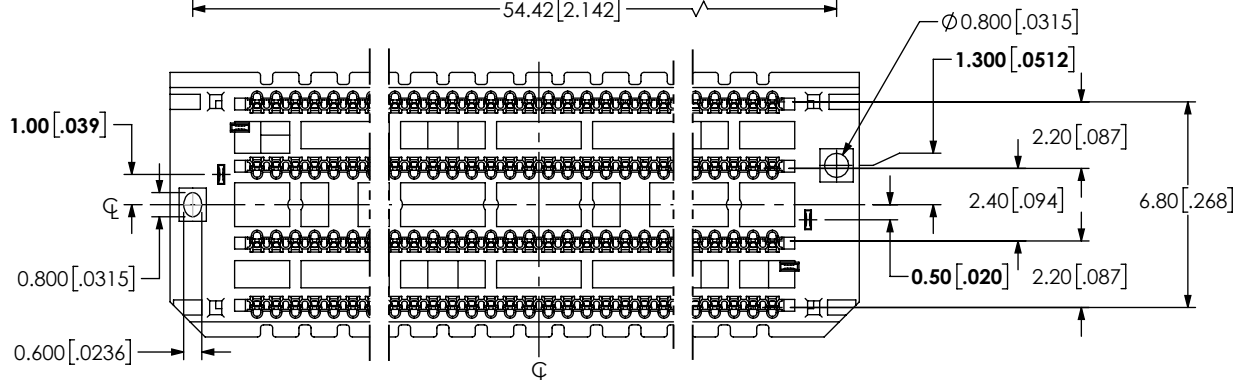
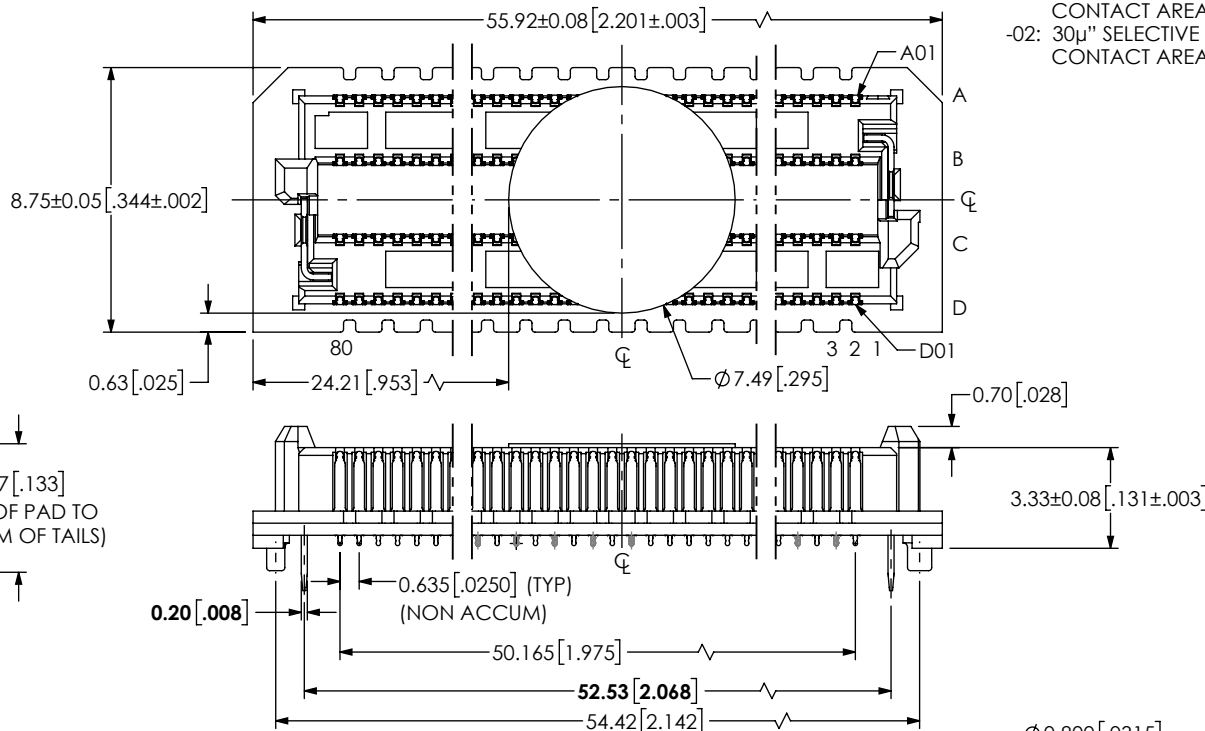
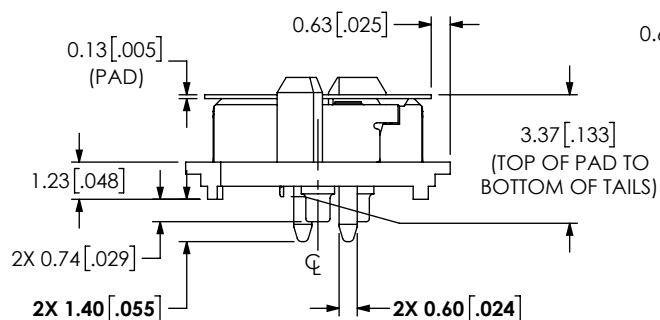

FIG 1
(ASP-240411-XX SHOWN)

NOTES:

1. SGET HFM INDUSTRY STANDARD COMPLIANT.
2. SEE SHEET 2 FOR PROCESSING INFORMATION.
3. PARTS TO BE PACKAGED IN TAPE & REEL.
4. ATTACH LABEL -4X2 TO EACH REEL.
5. ORDERS WILL BE PACKAGED ACCORDING TO THE SAMTEC PACKAGING EFFICIENCY STANDARDS (SPES) FOUND ON WWW.SAMTEC.COM.
6. NOTE DELETED.
7. -0 COLUMN TERMINATION CONNECTORS ARE SOLDERED WITH OPTIMIZED SOLDER PASTE VOLUME IN PLACE OF AN ATTACHED SOLDER BALL, USING OVERSIZED RECTANGULAR STENCIL APERTURES CENTERED OVER ROUND PCB PADS (DESIGN VERIFIED THROUGH TESTING). THE PASTE COALESCE DURING REFLOW TO FORM A COLUMNAR SOLDER JOINT. FOR MORE INFORMATION, CONTACT SAMTEC'S INTERCONNECT PROCESSING GROUP (IPG@SAMTEC.COM).

F:\DWORKING\SW\ASP\240000\ASP-240411-XX.SLDDRW

<p>PROPRIETARY NOTE</p> <p>THIS DOCUMENT CONTAINS CONFIDENTIAL AND PROPRIETARY INFORMATION AND ALL DESIGN, MANUFACTURING, REPRODUCTION, USE, PATENT RIGHTS AND SALES RIGHTS ARE EXPRESSLY RESERVED BY SAMTEC, INC. THIS DOCUMENT SHALL NOT BE DISCLOSED, IN WHOLE OR PART, TO ANY UNAUTHORIZED PERSON OR ENTITY NOR REPRODUCED, TRANSFERRED OR INCORPORATED IN ANY OTHER PROJECT IN ANY MANNER WITHOUT THE EXPRESS WRITTEN CONSENT OF SAMTEC, INC.</p>		<p>520 PARK EAST BLVD., NEW ALBANY, IN 47150 PHONE: 812-944-6733 FAX: 812-948-5047 e-Mail: info@SAMTEC.com code 53322</p>
<p>DO NOT SCALE DRAWING SHEET SCALE: 4:1</p> <p>MATERIAL: INSULATOR: LCP, COLOR: NATURAL TERMINAL: COPPER ALLOY WELD TAB: COPPER ALLOY PLATING: TERMINAL: ASP-240411-01: CONTACT AREA: .00010" REF GOLD REMAINDER: .000200" REF TIN ASP-240411-02: CONTACT AREA: .000300" REF GOLD REMAINDER: .000200" REF TIN WELD TAB: ENTIRE PIN: .000200" REF TIN</p>	<p>DESCRIPTION: CUSTOM SGET HFM HP MALE ASSEMBLY</p> <p>DWG. NO. ASP-240411-XX</p>	
<p>BY: TOBIN Q</p>		<p>11/19/2024 SHEET 1 OF 2</p>

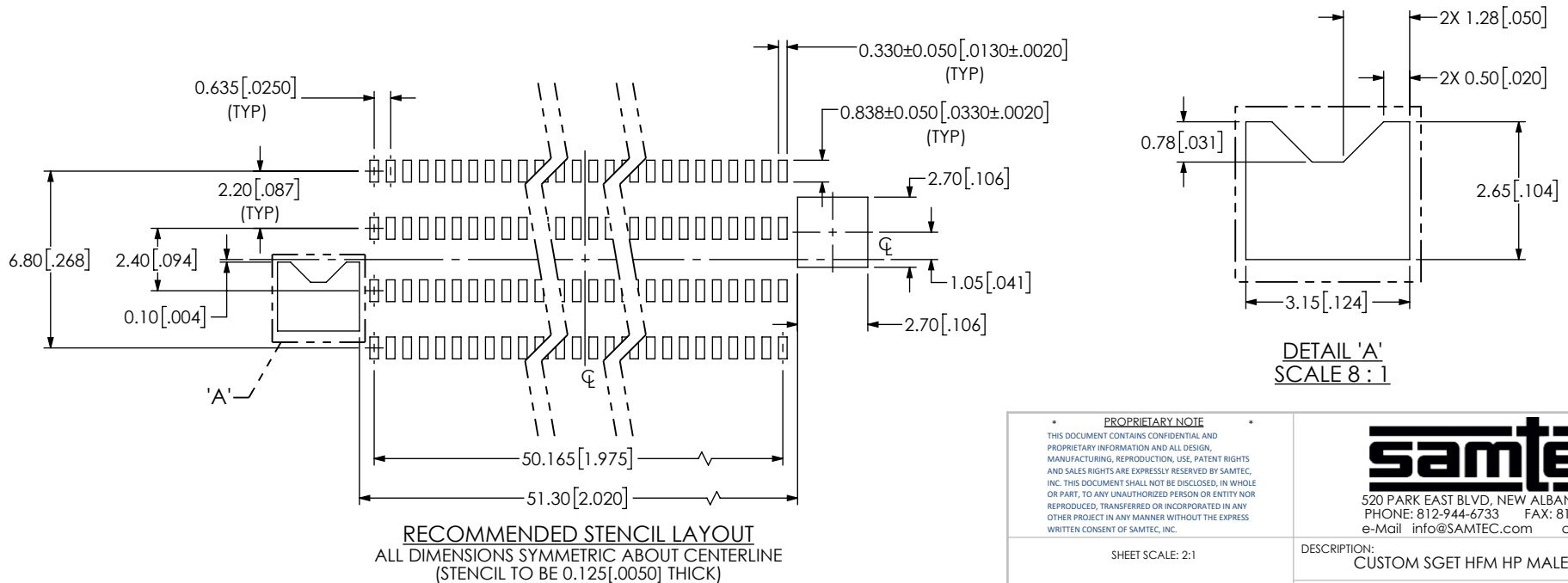
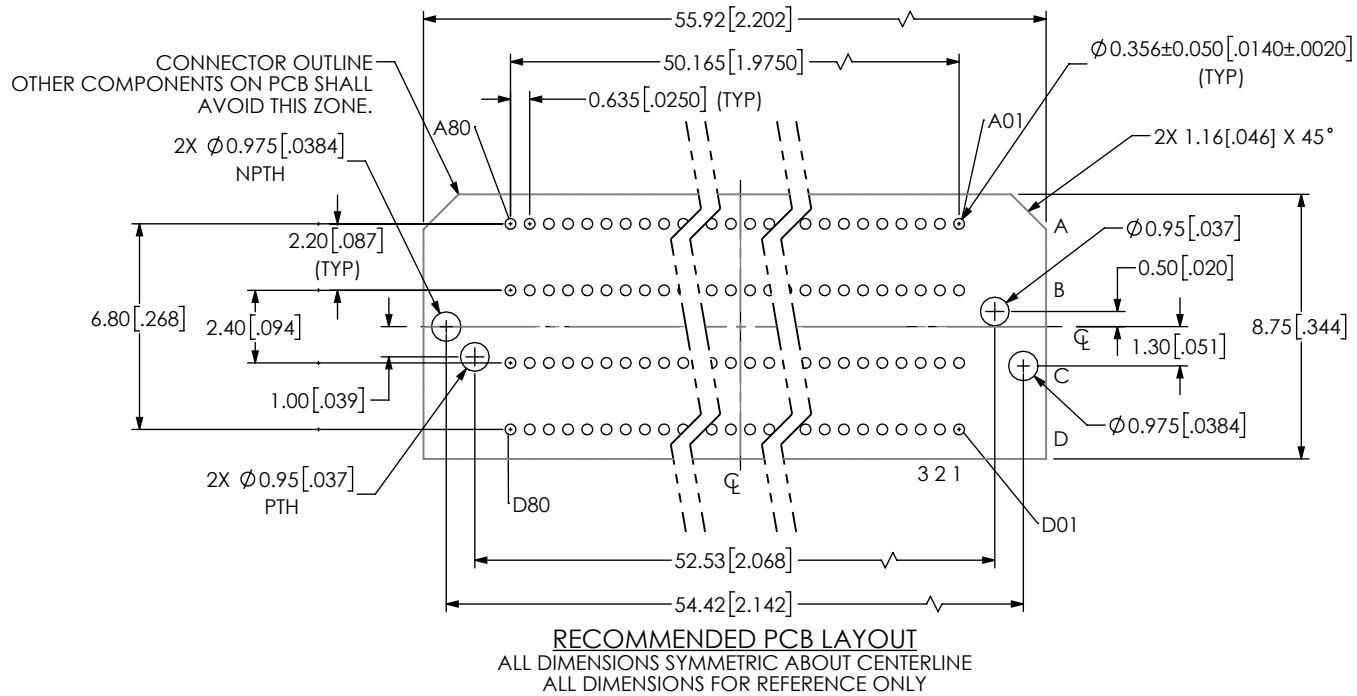

DETAIL 'A'
SCALE 8 : 1

<p>PROPRIETARY NOTE</p> <p>THIS DOCUMENT CONTAINS CONFIDENTIAL AND PROPRIETARY INFORMATION AND ALL DESIGN, MANUFACTURING, REPRODUCTION, USE, PATENT RIGHTS AND SALES RIGHTS ARE EXPRESSLY RESERVED BY SAMTEC, INC. THIS DOCUMENT SHALL NOT BE DISCLOSED, IN WHOLE OR PART, TO ANY UNAUTHORIZED PERSON OR ENTITY NOR REPRODUCED, TRANSFERRED OR INCORPORATED IN ANY OTHER PROJECT IN ANY MANNER WITHOUT THE EXPRESS WRITTEN CONSENT OF SAMTEC, INC.</p>	<p>520 PARK EAST BLVD., NEW ALBANY, IN 47150 PHONE: 812-944-6733 FAX: 812-948-5047 e-Mail info@SAMTEC.com code 55322</p>
	<p>DESCRIPTION: CUSTOM SGET HFM HP MALE ASSEMBLY</p>
	<p>DWG. NO. ASP-240411-XX</p>
<p>SHEET SCALE: 2:1</p>	<p>BY: TOBIN Q 11/19/2024 SHEET 2 OF 2</p>