

DO NOT
SCALE FROM
THIS PRINT

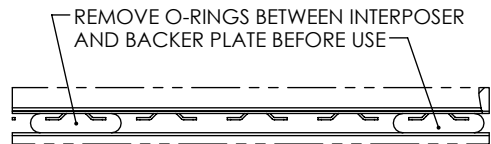

DETAIL 'A'
SCALE 3:1

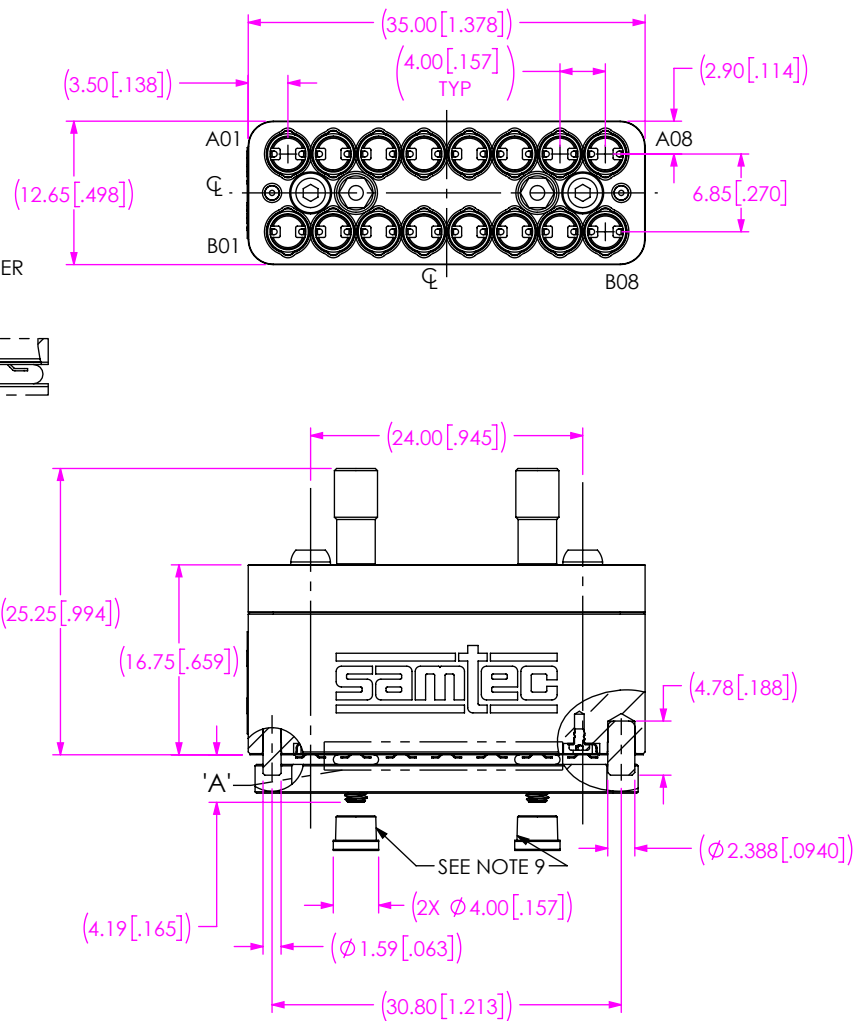

FIG 1
BE71B-J-S-2-12 AS SHOWN

NOTES:

1. REPRESENTS A CRITICAL DIMENSION.
2. CAT-EX-SCC-03 EXTRACTION TOOL SOLD SEPARATELY.
3. ASSEMBLY PACKAGED IN INDIVIDUAL BAG.
4. PRINT A01 AND B01 ON INDIVIDUAL LABELS AND APPLY TO BODY WHERE SHOWN.
5. TIGHTEN ITEM 4 TO 2.0-2.3 IN-LBS USING 0.05" HEX TOOL (NOT PROVIDED).
6. WHEN MOUNTED TO PCB, TIGHTEN ITEM 7 TO 2.0-2.5 IN-LBS USING 3MM HEX TOOL (NOT PROVIDED).
7. RECOMMEND PCB THICKNESS: .06 INCH - .16 INCH (SEE SHEET 5).
8. TIGHTEN ITEM 11 TO 0.174 IN-LBS USING PHILIPS SCREWDRIVERS.
9. DELETED NOTE
10. NUTS TO BE PACKAGED SEPARATELY IN ZB-1.5X2X2.

BE71B-J-X-X-XX

TRANSMISSION TYPE

- S: STRIPLINE
- M: MICROSTRIP

NO OF ROWS
-2

NO OF POSITION (PER ROW)
-04, -08,
*03, *06, *10, *12, *14, *16
(* = NOT RELEASED)

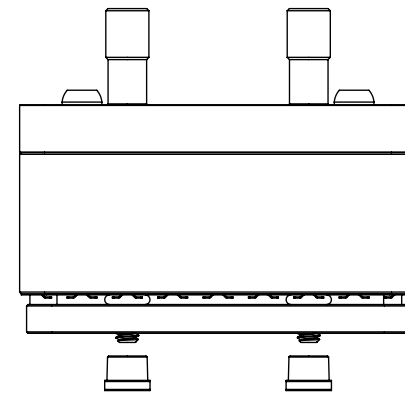
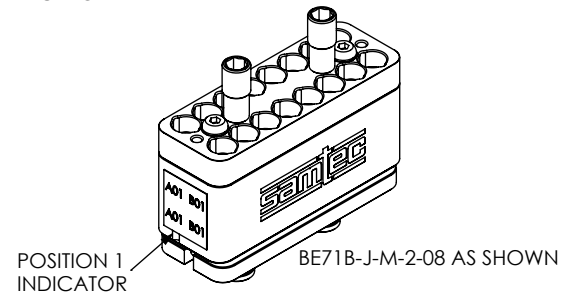
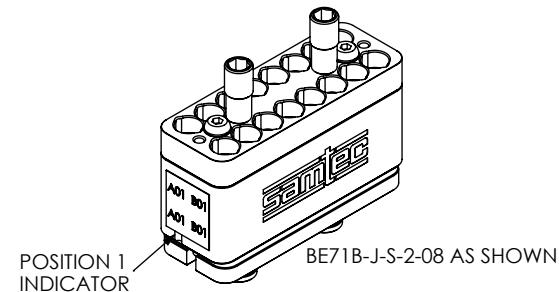

<p>PROPRIETARY NOTE</p> <p>THIS DOCUMENT CONTAINS CONFIDENTIAL AND PROPRIETARY INFORMATION AND ALL DESIGN, MANUFACTURING, REPRODUCTION, USE, PATENT RIGHTS AND SALES RIGHTS ARE EXPRESSLY RESERVED BY SAMTEC, INC. THIS DOCUMENT SHALL NOT BE DISCLOSED, IN WHOLE OR PART, TO ANY UNAUTHORIZED PERSON OR ENTITY NOR REPRODUCED, TRANSFERRED OR INCORPORATED IN ANY OTHER PROJECT IN ANY MANNER WITHOUT THE EXPRESS WRITTEN CONSENT OF SAMTEC, INC.</p>		<p>DESCRIPTION: BE71B HOUSING, VARIABLE POSITION COUNT</p> <p>DWG. NO. BE71B-J-X-X-XX</p>
<p>MATERIAL: DO NOT SCALE DRAWING SHEET SCALE: 3:2</p> <p>HOUSING, COVER, SCREWS, NUTS: BRASS PLATING: GOLD FLASH / 100µ"-200µ" Ni ALIGNMENT PINS, SCREWS, BACKER PLATE: STAINLESS STEEL PCB PIN: ALLOY STEEL INTERPOSER SCREW: BeCu O-RING: SILICONE RUBBER: STAINLESS STEEL</p>	<p>BY: HENRY W 2025/4/30 SHEET 1 OF 4</p>	

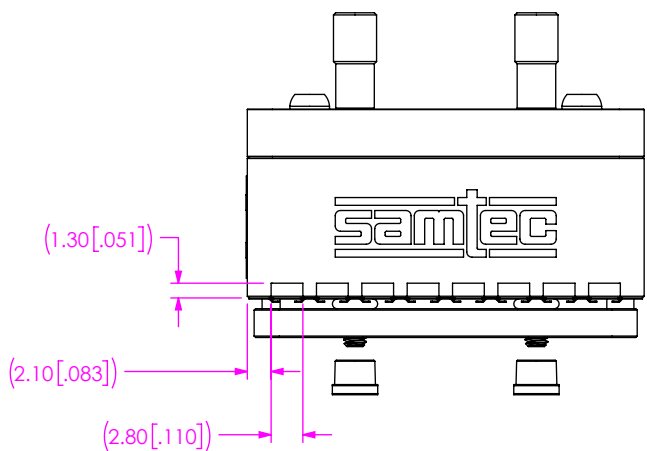

FIG 2
BE71B-J-M-2-08 AS SHOWN
(DIFFERENT AS SHOWN, OTHERWISE SAME AS FIG 1)

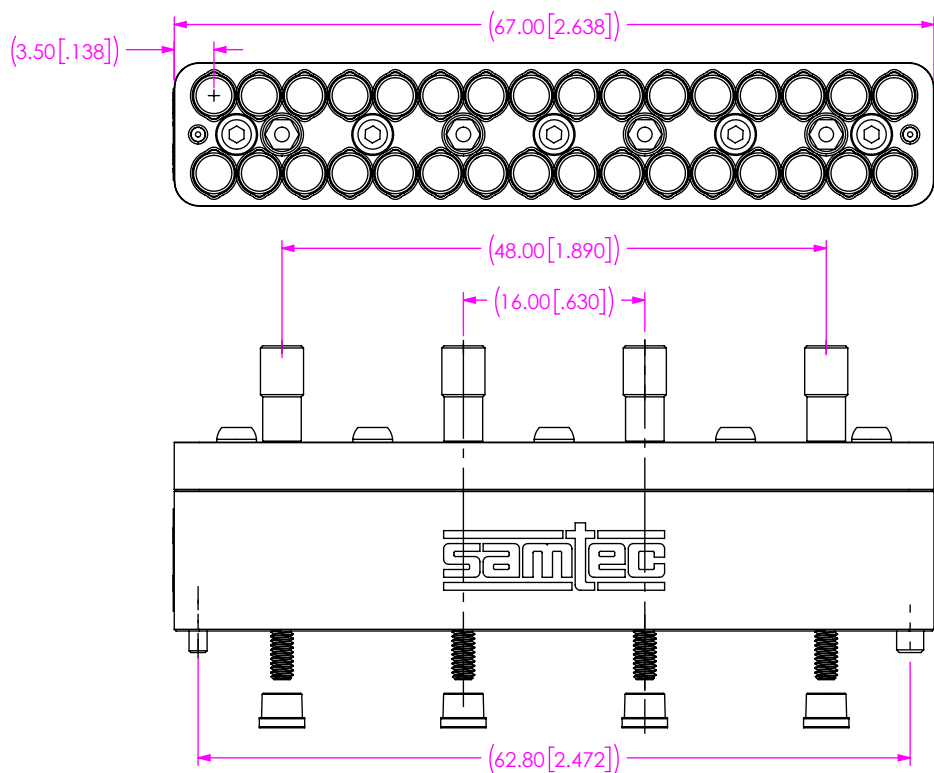

FIG 3
BE71B-J-S-2-16 AS SHOWN
(DIFFERENT AS SHOWN, OTHERWISE SAME AS FIG 1)

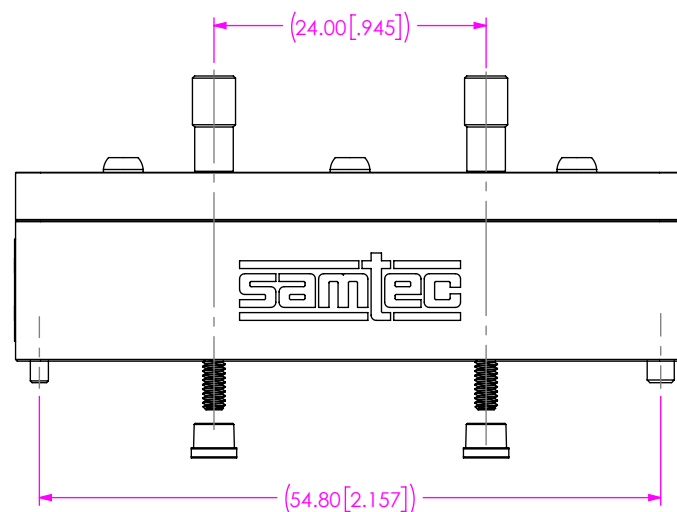
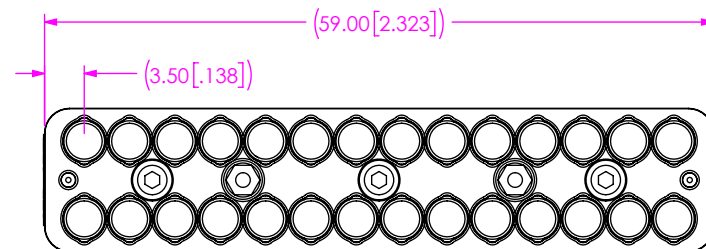



FIG 4
BE71B-J-S-2-14 AS SHOWN
(DIFFERENT AS SHOWN, OTHERWISE SAME AS FIG 1)

<p>PROPRIETARY NOTE THIS DOCUMENT CONTAINS CONFIDENTIAL AND PROPRIETARY INFORMATION AND ALL DESIGN, MANUFACTURING, REPRODUCTION, USE, PATENT RIGHTS AND SALES RIGHTS ARE EXPRESSLY RESERVED BY SAMTEC, INC. THIS DOCUMENT SHALL NOT BE DISCLOSED, IN WHOLE OR PART, TO ANY UNAUTHORIZED PERSON OR ENTITY NOR REPRODUCED, TRANSFERRED OR INCORPORATED IN ANY OTHER PROJECT IN ANY MANNER WITHOUT THE EXPRESS WRITTEN CONSENT OF SAMTEC, INC.</p>	 520 PARK EAST BLVD, NEW ALBANY, IN 47150 PHONE: 812-944-6733 FAX: 812-948-5047 e-Mail: info@SAMTEC.com code 55322
<p>SHEET SCALE: 3:2 DO NOT SCALE DRAWING</p>	<p>DESCRIPTION: BE71B HOUSING, VARIABLE POSITION COUNT DWG. NO. BE71B-J-X-X-XX BY: HENRY W 2025/4/30 SHEET 2 OF 4</p>

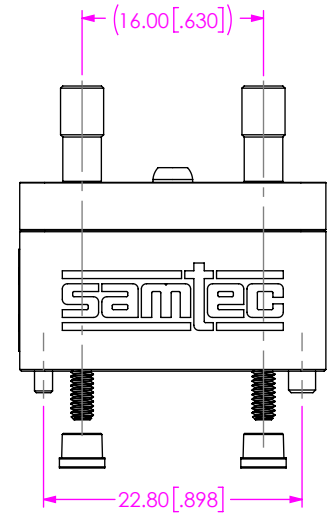
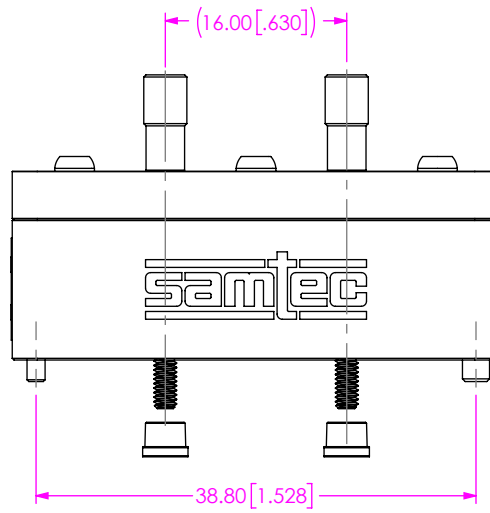
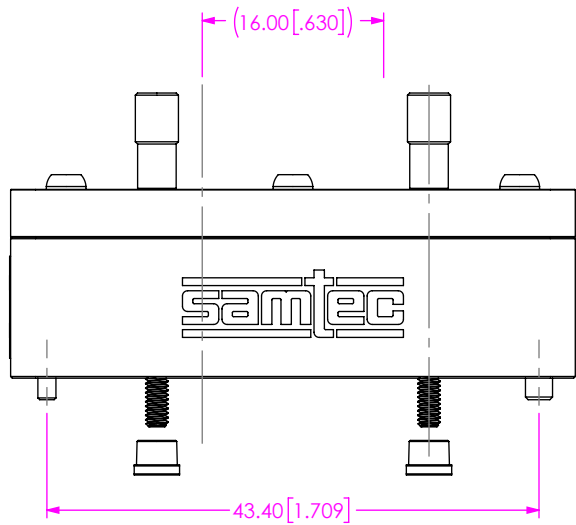
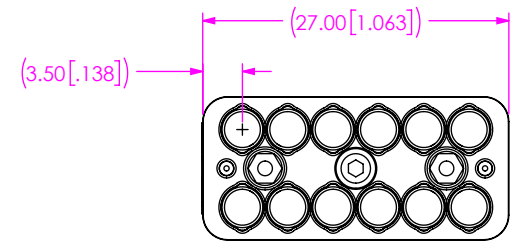
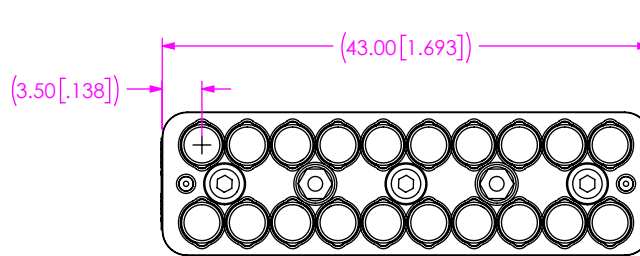
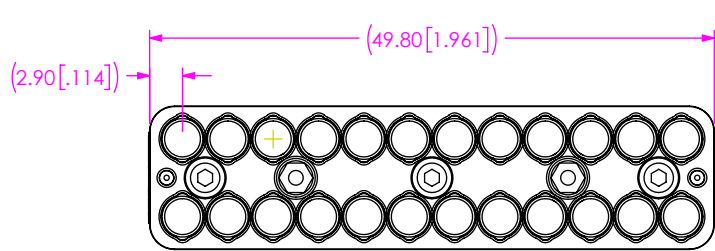

FIG 6
BE71B-J-S-2-12 AS SHOWN
(DIFFERENT AS SHOWN, OTHERWISE SAME AS FIG 1)

FIG 5
BE71B-J-S-2-10 AS SHOWN
(DIFFERENT AS SHOWN, OTHERWISE SAME AS FIG 1)

FIG 7
BE71B-J-S-2-06 AS SHOWN
(DIFFERENT AS SHOWN, OTHERWISE SAME AS FIG 1)

PROPRIETARY NOTE
 * THIS DOCUMENT CONTAINS CONFIDENTIAL AND PROPRIETARY INFORMATION AND ALL DESIGN, MANUFACTURING, REPRODUCTION, USE, PATENT RIGHTS AND SALES RIGHTS ARE EXPRESSLY RESERVED BY SAMTEC, INC. THIS DOCUMENT SHALL NOT BE DISCLOSED, IN WHOLE OR PART, TO ANY UNAUTHORIZED PERSON OR ENTITY NOR REPRODUCED, TRANSFERRED OR INCORPORATED IN ANY OTHER PROJECT IN ANY MANNER WITHOUT THE EXPRESS WRITTEN CONSENT OF SAMTEC, INC.

samtec
 520 PARK EAST BLVD., NEW ALBANY, IN 47150
 PHONE: 812-944-6733 FAX: 812-948-5047
 e-Mail info@SAMTEC.com code 55322

SHEET SCALE: 3:2
 DO NOT SCALE DRAWING

DESCRIPTION:
 BE71B HOUSING, VARIABLE POSITION COUNT
 DWG. NO. BE71B-J-X-X-XX

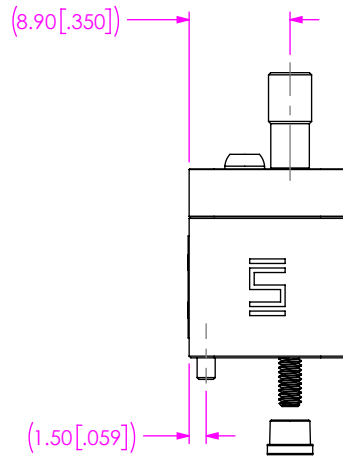
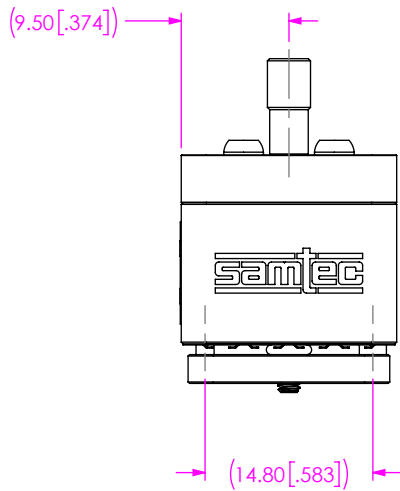
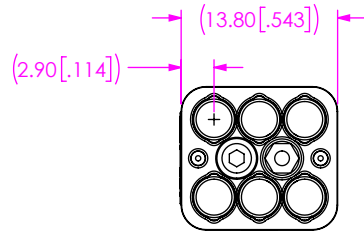
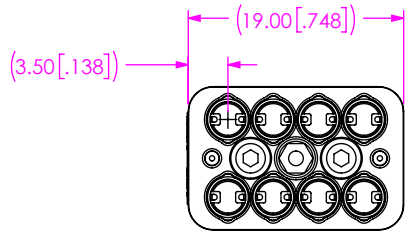
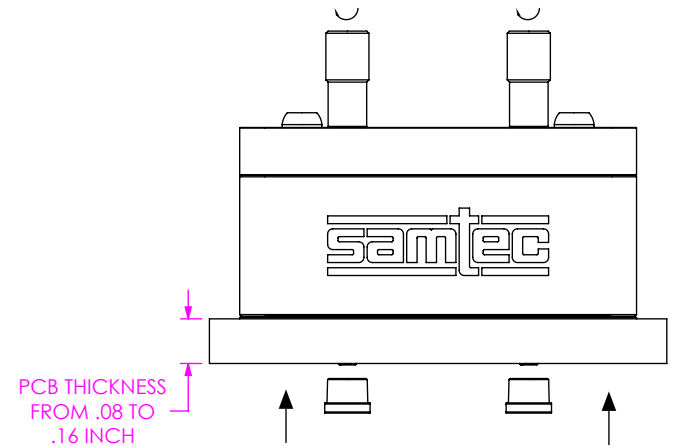
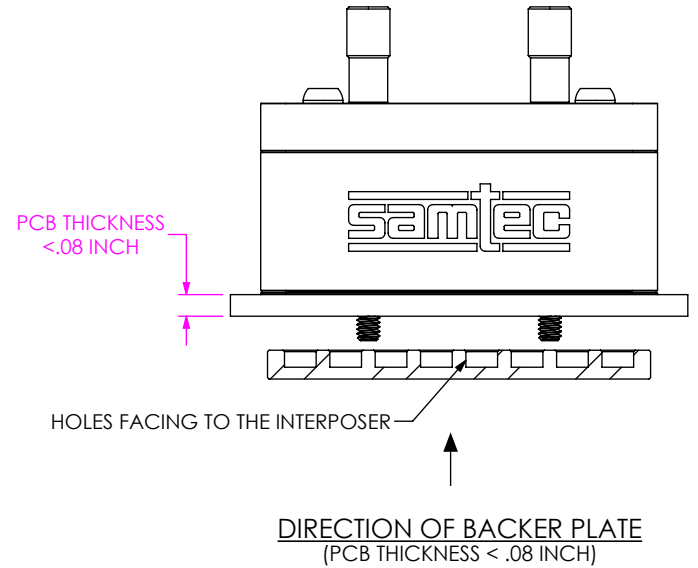

FIG 8
BE71B-J-S-2-04 AS SHOWN
(DIFFERENT AS SHOWN, OTHERWISE SAME AS FIG 1)

FIG 9
BE71B-J-S-2-03 AS SHOWN
(DIFFERENT AS SHOWN, OTHERWISE SAME AS FIG 1)



PROPRIETARY NOTE
THIS DOCUMENT CONTAINS CONFIDENTIAL AND PROPRIETARY INFORMATION AND ALL DESIGN, MANUFACTURING, REPRODUCTION, USE, PATENT RIGHTS AND SALES RIGHTS ARE EXPRESSLY RESERVED BY SAMTEC, INC. THIS DOCUMENT SHALL NOT BE DISCLOSED, IN WHOLE OR PART, TO ANY UNAUTHORIZED PERSON OR ENTITY NOR REPRODUCED, TRANSFERRED OR INCORPORATED IN ANY OTHER PROJECT IN ANY MANNER WITHOUT THE EXPRESS WRITTEN CONSENT OF SAMTEC, INC.

samtec
520 PARK EAST BLVD, NEW ALBANY, IN 47150
PHONE: 812-944-6733 FAX: 812-948-5047
e-Mail info@SAMTEC.com code 55322

SHEET SCALE: 3:2
DO NOT SCALE DRAWING

DESCRIPTION:
BE71B HOUSING, VARIABLE POSITION COUNT

DWG. NO.
BE71B-J-X-X-XX