

DO NOT
SCALE FROM
THIS PRINT

TABLE 1			
ITEM	COMPONENT	-HN	-GN
1	SUB ASSEMBLY	SUB-BNC5-P-C-N-ST-CA2	
2	PIN	BNC5-P-C-H-ST-CA2-PIN	BNC5-P-C-G-ST-CA2-PIN
3	INSULATOR	BNC5-INS-002	
4	INNER FERRULE	MCX-FER-011-N	
5	OUTER FERRULE	MCX-FER-004-N	

BNC5-P-C-XX-ST-CA2

GENDER
-P: PLUG

TYPE
-C: CABLE

TERMINATION
-CA2: CCA-178 CABLE

ORIENTATION
-ST: STRAIGHT

PLATING SPECIFICATION
-HN: HEAVY GOLD / NICKEL
30µ" Au / 50µ" Ni MIN ON PIN
100µ" Ni MIN ON OUTER CONTACT
-GN: GOLD / NICKEL
10µ" Au / 50µ" Ni MIN ON PIN
100µ" Ni MIN ON OUTER CONTACT
(SEE TABLE 1)

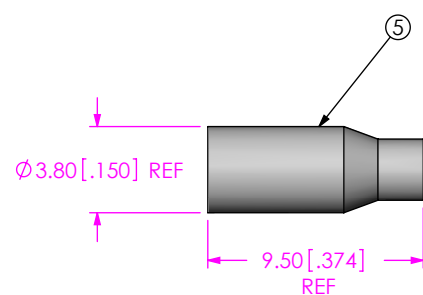
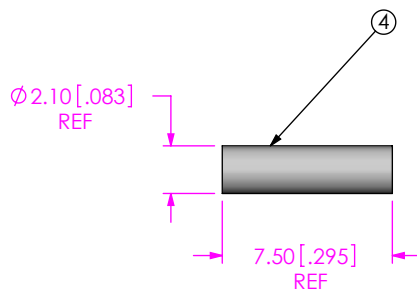
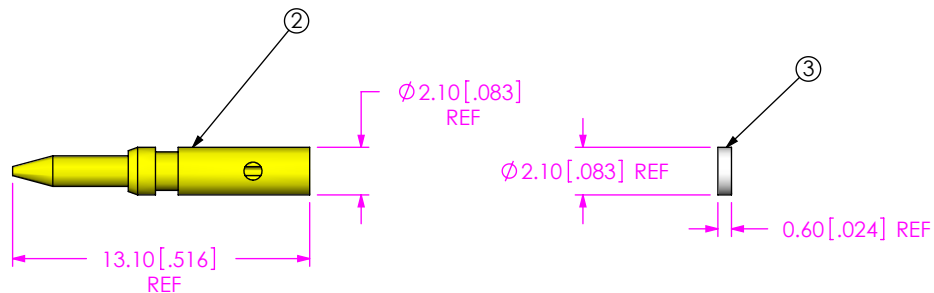
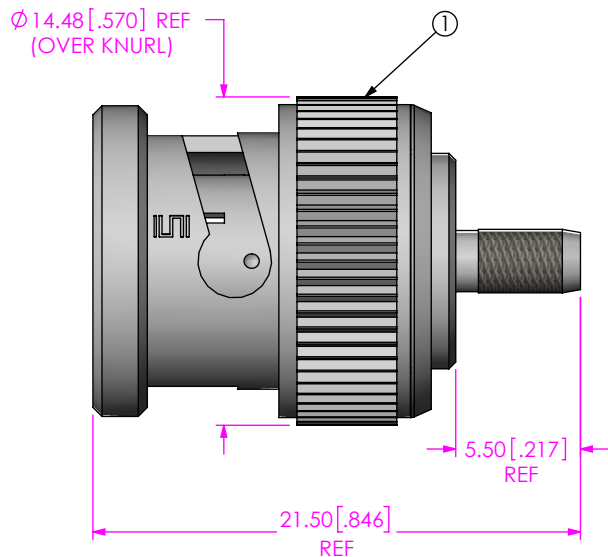

NOTES:

- 1. NOTE DELETED.
- 2. NOTE DELETED.

UNLESS OTHERWISE SPECIFIED,
DIMENSIONS ARE IN
MILLIMETERS [INCHES].
TOLERANCES ARE:

DECIMALS ANGLES
X.X: ±0.3 [01] 5°
X.XX: ±0.13 [005]
X.XXX: ±0.051 [0020]

PROPRIETARY NOTE

THIS DOCUMENT CONTAINS CONFIDENTIAL AND PROPRIETARY INFORMATION AND ALL DESIGN, MANUFACTURING, REPRODUCTION, USE, PATENT RIGHTS AND SALES RIGHTS ARE EXPRESSLY RESERVED BY SAMTEC, INC. THIS DOCUMENT SHALL NOT BE DISCLOSED, IN WHOLE OR PART, TO ANY UNAUTHORIZED PERSON OR ENTITY NOR REPRODUCED, TRANSFERRED OR INCORPORATED IN ANY OTHER PROJECT IN ANY MANNER WITHOUT THE EXPRESS WRITTEN CONSENT OF SAMTEC, INC.

MATERIAL: DO NOT SCALE DRAWING SHEET SCALE: 3:1
COUPLING NUT, CABLE BODY, PIN, FERRULES: BRASS
DIELECTRIC: PTFE
GASKET: SILICONE
C-RING, FLAT WASHER: FE
SPRING WASHER: STAINLESS STEEL



520 PARK EAST BLVD, NEW ALBANY, IN 47150
PHONE: 812-944-6733 FAX: 812-948-5047
e-Mail info@SAMTEC.com code 55322

DESCRIPTION:
50 OHM, BNC STRAIGHT PLUG, RG178

DWG. NO.
BNC5-P-C-XX-ST-CA2

BY: ALVIN W 03/18/2011 SHEET 1 OF 2

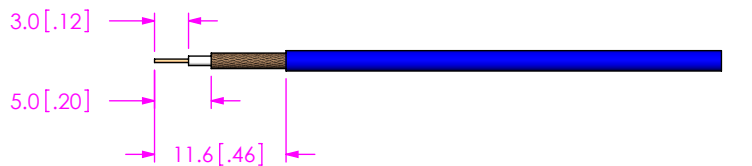

IN PROCESS 1
STRIP CABLE AND TIN INNER CONDUCTOR

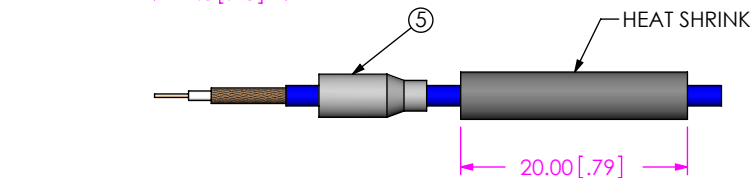

IN PROCESS 2
ADD HEAT SHRINK TUBING & OUTER FERRULE

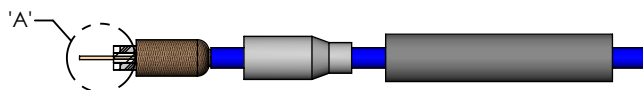
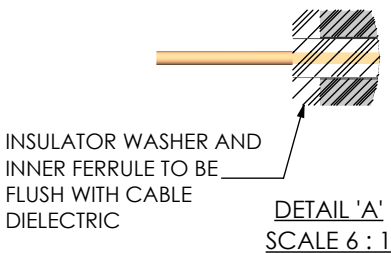

IN PROCESS 3
FLARE SHIELD, ADD INSULATOR & INNER FERRULE

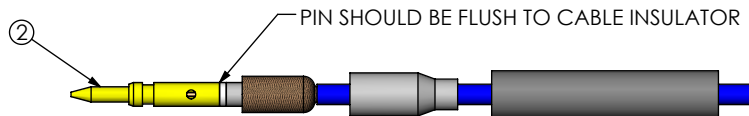

IN PROCESS 4
FLARE SHIELD, SOLDER SIGNAL PIN

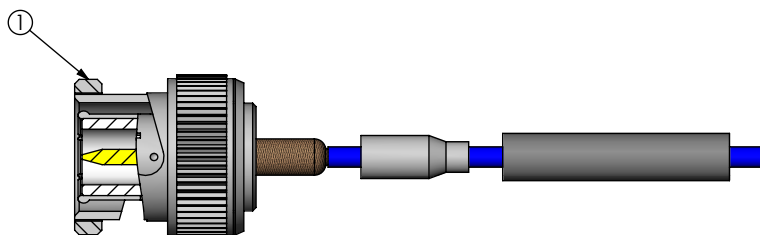

IN PROCESS 5
ADD SUB ASSEMBLY

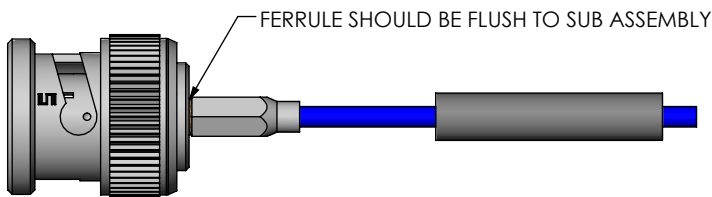

IN-PROCESS 6
CRIMP FERRULE
(USE RF CRIMP HAND TOOL #CAT-RF-FER-001
USE 0.136" DIE SIZE)

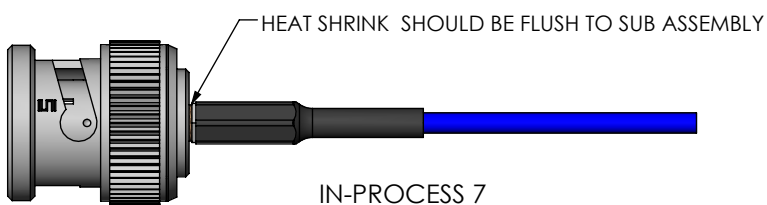

IN-PROCESS 7
ACTIVATE HEAT SHRINK

PROPRIETARY NOTE
THIS DOCUMENT CONTAINS CONFIDENTIAL AND PROPRIETARY INFORMATION AND ALL DESIGN, MANUFACTURING, REPRODUCTION, USE, PATENT RIGHTS AND SALES RIGHTS ARE EXPRESSLY RESERVED BY SAMTEC, INC. THIS DOCUMENT SHALL NOT BE DISCLOSED, IN WHOLE OR PART, TO ANY UNAUTHORIZED PERSON OR ENTITY NOR REPRODUCED, TRANSFERRED OR INCORPORATED IN ANY OTHER PROJECT IN ANY MANNER WITHOUT THE EXPRESS WRITTEN CONSENT OF SAMTEC, INC.

DO NOT SCALE DRAWING

SHEET SCALE: 3:2



520 PARK EAST BLVD, NEW ALBANY, IN 47150
PHONE: 812-944-6733 FAX: 812-948-5047
e-Mail info@SAMTEC.com code 55322

DESCRIPTION:
50 OHM, BNC STRAIGHT PLUG, RG178

DWG. NO.
BNC5-P-C-XX-ST-CA2

BY: ALVIN W 03/18/2011 SHEET 2 OF 2