

DO NOT SCALE FROM THIS PRINT

GENDER
-P: PLUG

TYPE
-C: CABLE

PACKAGING
-BLANK: INDIVIDUALLY BAGGED
-B: BULK PACKAGED (QTY=100 MAX)

TERMINATION
-CA6: CCA-6
CCA-1694A
-CA6B: CCA-4694R

ORIENTATION
-RA: RIGHT ANGLE

PLATING
-GN: GOLD / NICKEL
10µ" Au / 50µ" Ni MIN ON PIN
100µ" Ni MIN ON OUTER CONTACT

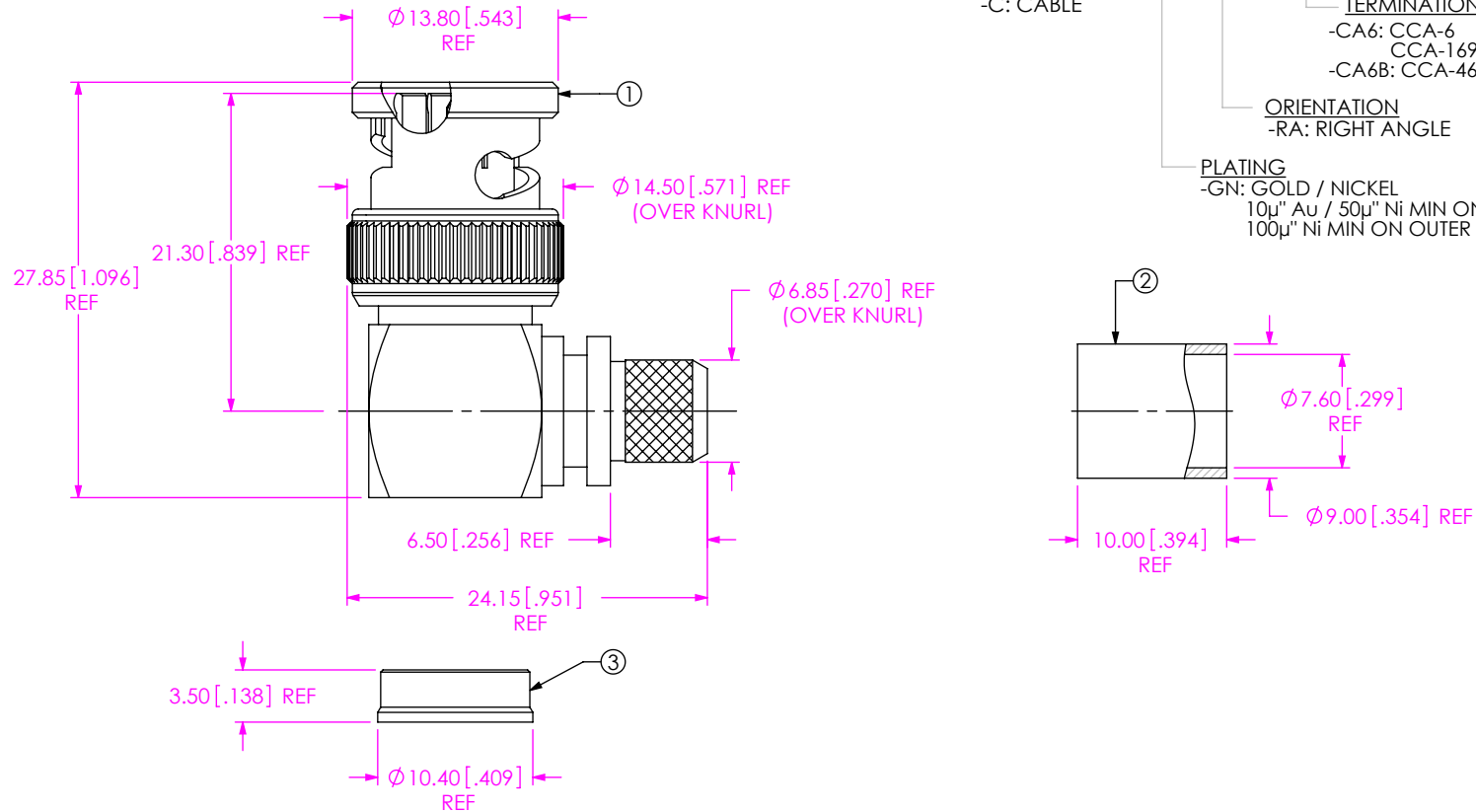

ITEM	COMPONENT	-CA6	-CA6B
1	SUB ASSEMBLY	SUB-BNC7T-P-C-GN-RA-CA6	SUB-BNC7T-P-C-GN-RA-CA6B
2	FERRULE	BNC-FER-001-N	
3	CAP	BNC7T-P-C-N-RA-CA6-CAP	

NOTES:

1. REPRESENTS A CRITICAL DIMENSION.
2. PUSHOUT FORCE FOR CENTER CONTACT: 26.69N [6LBS] MIN.
3. SEE SHEET 2 FOR TERMINATION INFORMATION.
4. NOTE DELETED.
5. PRODUCT TO BE PACKAGED PER PRECISION RF SECTION OF PACKAGING MANUAL.
6. RoHS COMPLIANT.
7. NOTE DELETED
8. NOTE DELETED

<p>UNLESS OTHERWISE SPECIFIED DIMENSIONS ARE IN MILLIMETERS [INCHES]</p> <p>TOLERANCES ARE:</p> <p>DECIMALS ANGLES</p> <p>.X: ±0.3 [.01] 5°</p> <p>.XX: ±0.13 [.005]</p> <p>.XXX: ±0.051 [.0020]</p>	<p>PROPRIETARY NOTE</p> <p>THIS DOCUMENT CONTAINS CONFIDENTIAL AND PROPRIETARY INFORMATION AND ALL DESIGN, MANUFACTURING, REPRODUCTION, USE, PATENT RIGHTS AND SALES RIGHTS ARE EXPRESSLY RESERVED BY SAMTEC, INC. THIS DOCUMENT SHALL NOT BE DISCLOSED, IN WHOLE OR PART, TO ANY UNAUTHORIZED PERSON OR ENTITY NOR REPRODUCED, TRANSFERRED OR INCORPORATED IN ANY OTHER PROJECT IN ANY MANNER WITHOUT THE EXPRESS WRITTEN CONSENT OF SAMTEC, INC.</p>	 <p>520 PARK EAST BLVD, NEW ALBANY, IN 47150 PHONE: 812-944-6733 FAX: 812-948-5047 e-Mail: info@SAMTEC.com code 55322</p> <p>DESCRIPTION: TRUE 75 OHM, BNC RA RG6 CABLE PLUG</p> <p>DWG. NO. BNC7T-P-C-XX-RA-CA6X-X</p> <p>BY: G. HERMAN 01/09/2009 SHEET 1 OF 3</p>
<p>MATERIAL: DO NOT SCALE DRAWING SHEET SCALE: 2:1</p> <p>SHELL, FERRULE, NUT, CAP: BRASS CONTACT: BRASS DIELECTRIC: PTFE GASKET: SILICONE</p>		

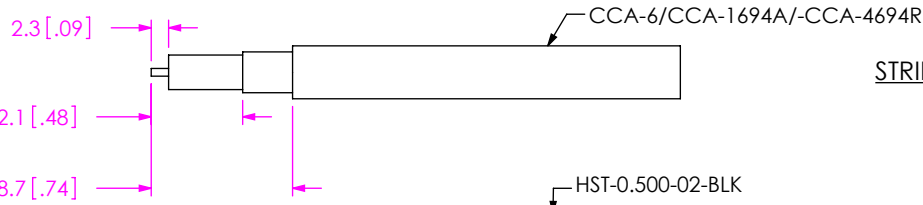

STRIP AND TIN INNER CONDUCTOR

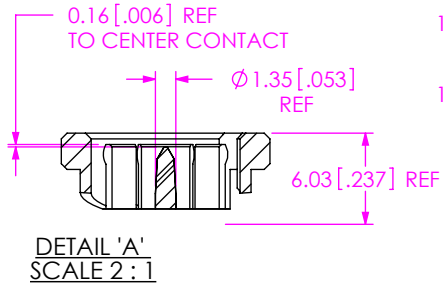

ADD HEAT SHRINK TUBE AND FERRULE

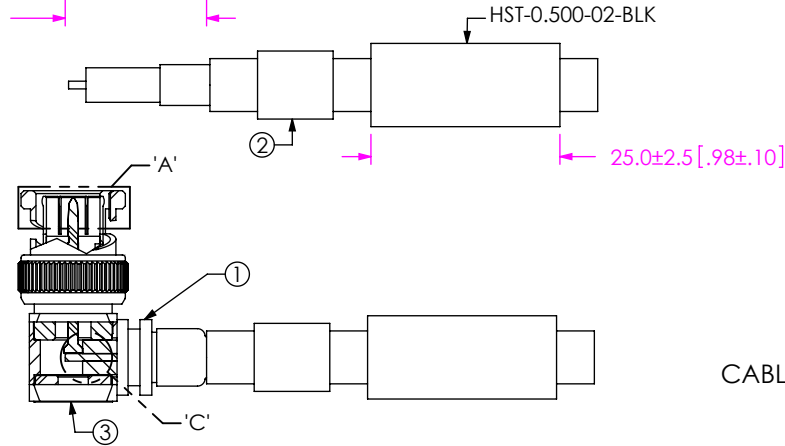

FLAIR BRAID AND ADD SUB-BNC7T-P-C-XX-RA-CA6X CABLE FOIL WRAP TO BE INSERTED INSIDE CABLE BODY

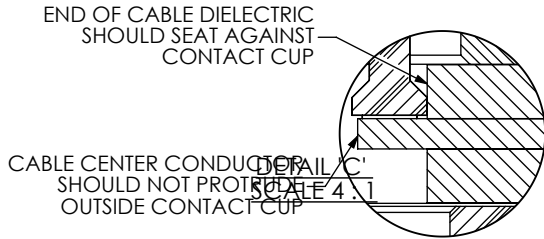

CRIMP FERRULE AND SOLDER SIGNAL PIN (USE RF CRIMP HAND TOOL # CAT-HT-126667-21 OR EQUIVALENT) (USE .325 HEX DIE FOR CCA-4694R CABLE.)

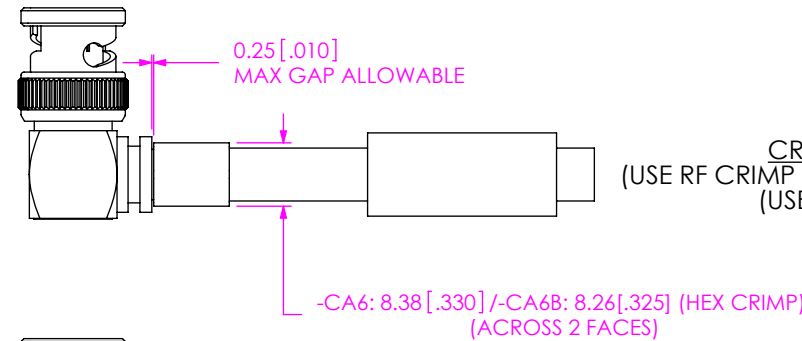
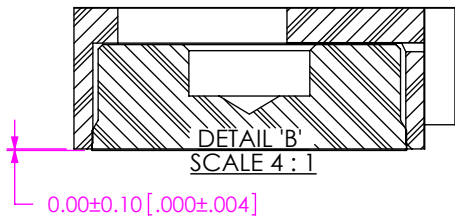

INSERT CAP

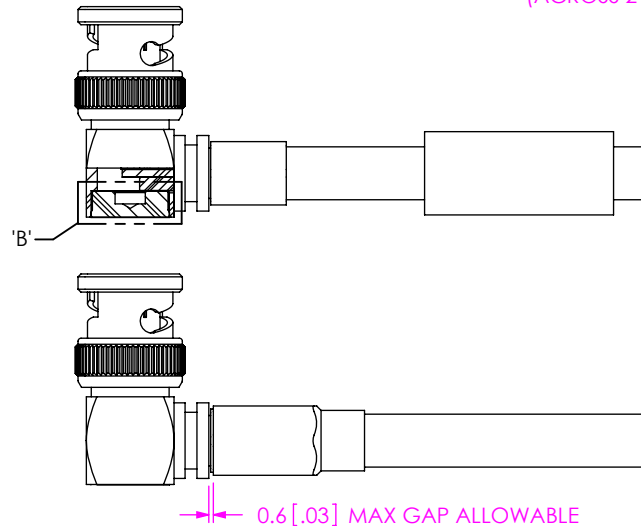

APPLY HEAT SHRINK TUBING

F:\DWG\MISC\MKTG\BNC7T-P-C-XX-RA-CA6X-X-MKT.SLDDRW

<p>PROPRIETARY NOTE</p> <p>THIS DOCUMENT CONTAINS CONFIDENTIAL AND PROPRIETARY INFORMATION AND ALL DESIGN, MANUFACTURING, REPRODUCTION, USE, PATENT RIGHTS AND SALES RIGHTS ARE EXPRESSLY RESERVED BY SAMTEC, INC. THIS DOCUMENT SHALL NOT BE DISCLOSED, IN WHOLE OR PART, TO ANY UNAUTHORIZED PERSON OR ENTITY NOR REPRODUCED, TRANSFERRED OR INCORPORATED IN ANY OTHER PROJECT IN ANY MANNER WITHOUT THE EXPRESS WRITTEN CONSENT OF SAMTEC, INC.</p> <p>DO NOT SCALE DRAWING</p> <p>SHEET SCALE: 1:1</p>	 <p>520 PARK EAST BLVD. NEW ALBANY, IN 47150 PHONE: 812-944-6733 FAX: 812-948-5047 e-Mail info@SAMTEC.com code 55322</p>
	<p>DESCRIPTION: TRUE 75 OHM, BNC RA RG6 CABLE PLUG</p>
	<p>DWG. NO. BNC7T-P-C-XX-RA-CA6X-X</p>
	<p>BY: G. HERMAN 01/09/2009 SHEET 2 OF 3</p>

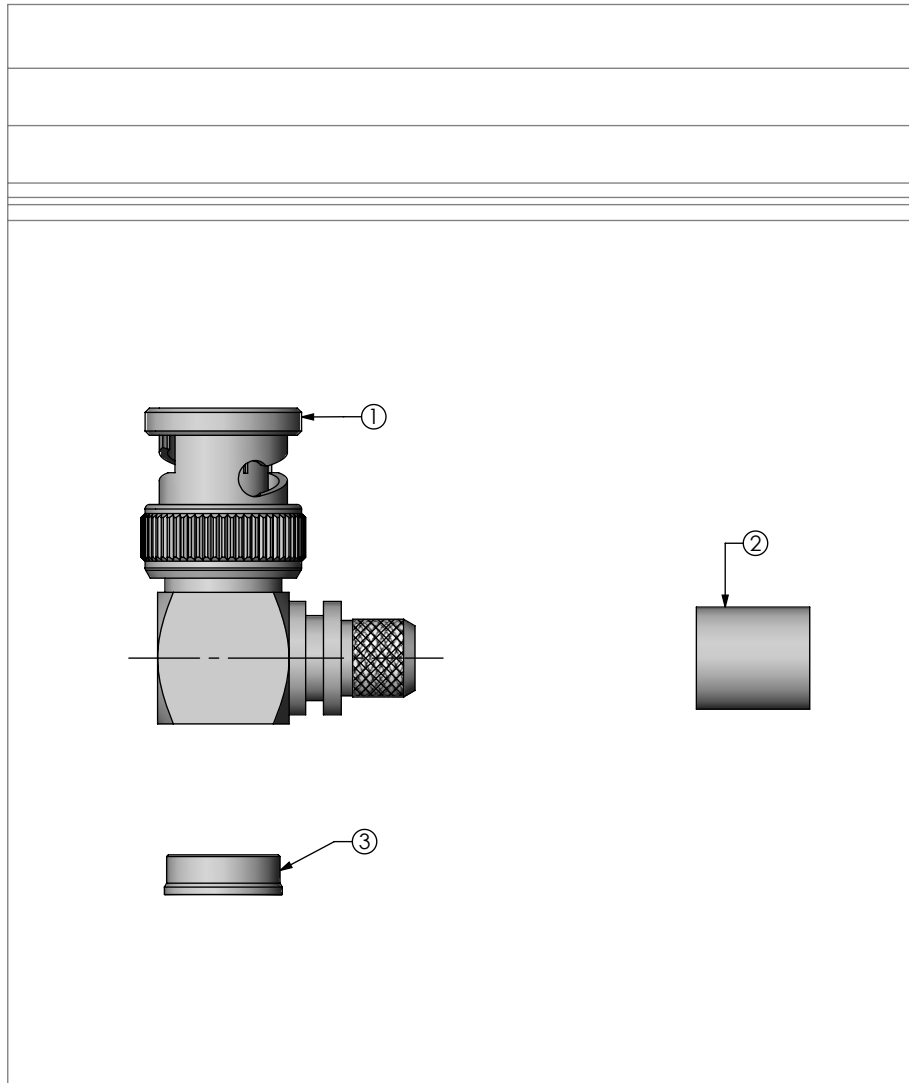

BNC7T-P-C-XX-RA-CA6X SHOWN

PROPRIETARY NOTE

THIS DOCUMENT CONTAINS CONFIDENTIAL AND PROPRIETARY INFORMATION AND ALL DESIGN, MANUFACTURING, REPRODUCTION, USE, PATENT RIGHTS AND SALES RIGHTS ARE EXPRESSLY RESERVED BY SAMTEC, INC. THIS DOCUMENT SHALL NOT BE DISCLOSED, IN WHOLE OR PART, TO ANY UNAUTHORIZED PERSON OR ENTITY NOR REPRODUCED, TRANSFERRED OR INCORPORATED IN ANY OTHER PROJECT IN ANY MANNER WITHOUT THE EXPRESS WRITTEN CONSENT OF SAMTEC, INC.



520 PARK EAST BLVD, NEW ALBANY, IN 47150
 PHONE: 812-944-6733 FAX: 812-948-5047
 e-Mail info@SAMTEC.com code 55322

DO NOT SCALE DRAWING SHEET SCALE: 2:1
 INSULATOR:
 CONTACT OR TERMINAL:
 SHIELD: PHOS BRONZE
 PLATING:
 CONTACT AREA: .000010 REF GOLD
 REMAINDER: .000200 REF TIN

DESCRIPTION:
 TRUE 75 OHM, BNC RA RG6 CABLE PLUG

DWG. NO.
BNC7T-P-C-XX-RA-CA6X-X

BY: G. HERMAN 01/09/2009 SHEET 3 OF 3