

Pb THIS PRODUCT MANUFACTURED WITH LEAD-FREE PROCESSING

DESIGNED & DIMENSIONED IN MILLIMETERS [INCHES]

BNC7T-P-C-XX-ST-CA6DX

DO NOT SCALE FROM THIS PRINT

TABLE 1		
ITEM	COMPONENT	-GN
1	SUB-ASSEMBLY	SUB-BNC7T-P-C-N-ST-CA6D
2	PIN	BNC7T-P-C-G-ST-CA6-PIN-X (SEE TABLE 2)
3	FERRULE	BNC-FER-001-N

TABLE 2	
OPTION	PIN
-CA6D	BNC7T-P-C-G-ST-CA6-PIN
-CA6DC	BNC7T-P-C-G-ST-CA6-PIN-C

GENDER
-P: PLUG

TYPE
-C: CABLE

CRIMP OPTION
(LEAVE BLANK FOR SOLDERED CENTER CONTACT)
-C: CRIMPABLE CENTER CONTACT
(USE BNC7T-P-C-X-ST-CA6-PIN-C)

TERMINATION
-CA6D: DIE CAST COUPLING NUT
CCA-6 CABLE (RG6)

ORIENTATION
-ST: STRAIGHT

PLATING SPECIFICATION
-GN: GOLD / NICKEL
10µ" Au / 50µ" Ni MIN ON PIN
100µ" Ni MIN ON OUTER CONTACT
(SEE TABLE 1)

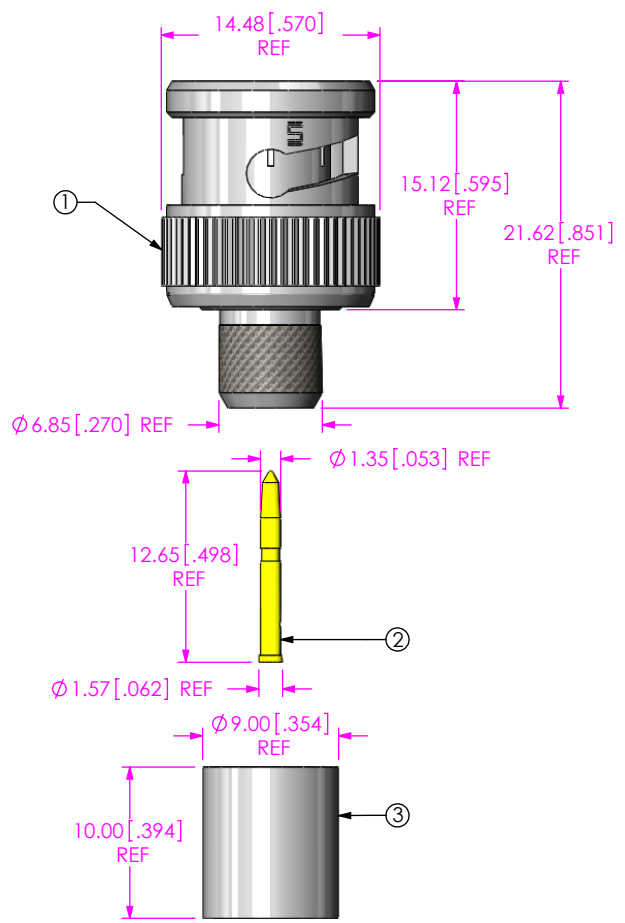

- NOTES:
- ① REPRESENTS A CRITICAL DIMENSION.
 - PUSHOUT FORCE FOR CENTER CONTACT: 26.69 N [6.0 LB] MIN.
 - COMPONENTS TO BE SHIPPED UNASSEMBLED.
 - PRODUCT TO BE PACKAGED PER PACKAGING STANDARD COJ-HD-WI-3033-M.
 - RoHS COMPLIANT.

UNLESS OTHERWISE SPECIFIED DIMENSIONS ARE IN MILLIMETERS [INCHES]

TOLERANCES ARE:

DECIMALS	ANGLES
.X: ±0.3 [01]	5°
.XX: ±0.13 [005]	
.XXX: ±0.051 [0020]	

PROPRIETARY NOTE
THIS DOCUMENT CONTAINS INFORMATION CONFIDENTIAL AND PROPRIETARY TO SAMTEC, INC. AND SHALL NOT BE REPRODUCED OR TRANSFERRED TO OTHER DOCUMENTS OR DISCLOSED TO OTHERS OR USED FOR ANY PURPOSE OTHER THAN THAT WHICH IT WAS OBTAINED WITHOUT THE EXPRESSED WRITTEN CONSENT OF SAMTEC, INC.

MATERIAL: DO NOT SCALE DRAWING SHEET SCALE: 1:1
SHELL, FERRULE, NUT: BRASS
CONTACT: BRASS
DIELECTRIC: PTFE
GASKET: SILICONE

520 PARK EAST BLVD, NEW ALBANY, IN 47150
PHONE: 812-944-6733 FAX: 812-948-5047
e-Mail: info@SAMTEC.com code: 55322

DESCRIPTION:
TRUE 75 OHM STRAIGHT DIE CAST PLUG RG-6

DWG. NO.
BNC7T-P-C-XX-ST-CA6DX

BY: T. MEEK 11/17/2009 SHEET 1 OF 2

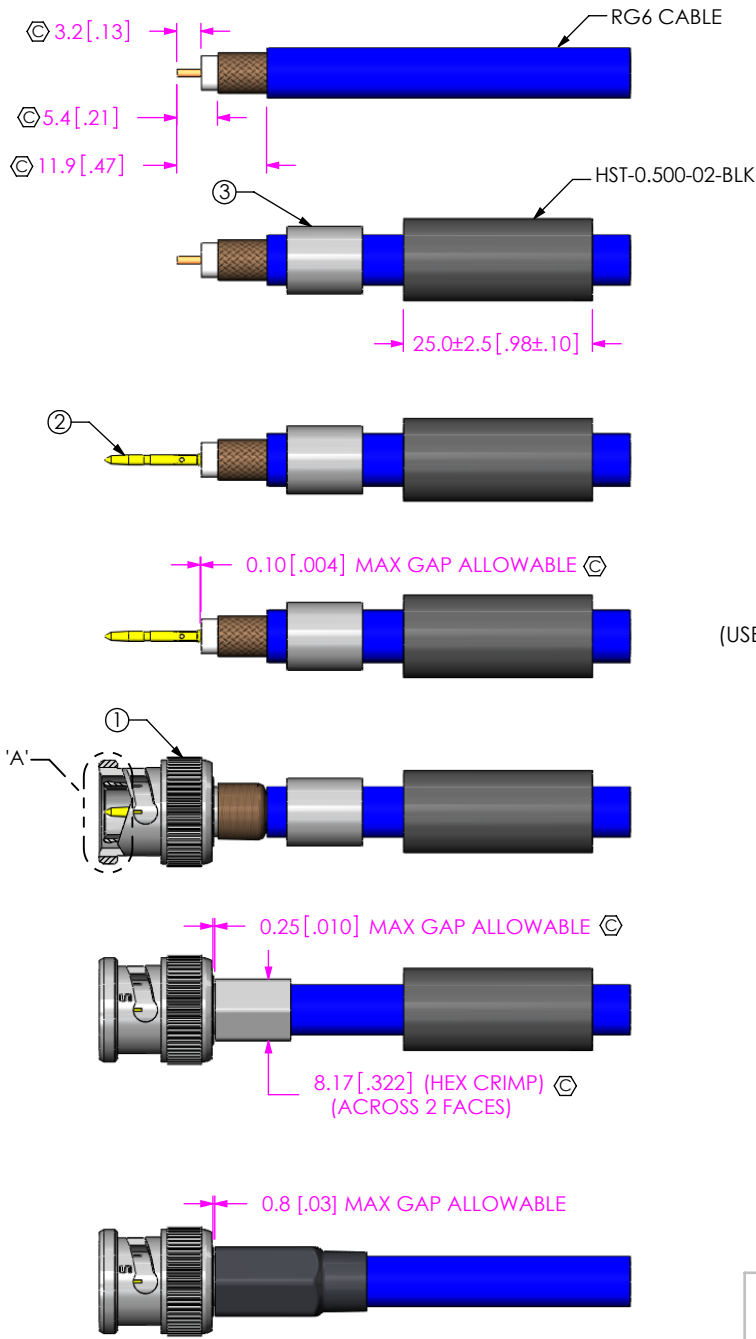

IN-PROCESS 1
STRIP AND TIN INNER CONDUCTOR

IN-PROCESS 2
ADD HEAT SHRINK TUBE AND FERRULE

IN-PROCESS 3
ADD SIGNAL PIN

IN-PROCESS 4
SOLDER SIGNAL PIN, OR CRIMP
(USE DANIELS WA22CJ TOOL AND K1764 POSITIONER, CRIMP ON SETTING 6)

IN-PROCESS 5
FLARE BRAIDED SHIELD AND ADD SUB-BNC75-P-C-X-ST-CA6D
CABLE FOIL WRAP TO BE INSERTED INSIDE CABLE BODY

IN-PROCESS 6
CRIMP FERRULE
(USE .324 HEX DIE)

IN-PROCESS 7
APPLY HEAT SHRINK TUBE

DETAIL 'A'
SCALE 4:1

PROPRIETARY NOTE

THIS DOCUMENT CONTAINS INFORMATION CONFIDENTIAL AND PROPRIETARY TO SAMTEC, INC. AND SHALL NOT BE REPRODUCED OR TRANSFERRED TO OTHER DOCUMENTS OR DISCLOSED TO OTHERS OR USED FOR ANY PURPOSE OTHER THAN THAT WHICH IT WAS OBTAINED WITHOUT THE EXPRESSED WRITTEN CONSENT OF SAMTEC, INC.

DO NOT SCALE DRAWING

SHEET SCALE: 1:1

samtec

520 PARK EAST BLVD, NEW ALBANY, IN 47150
PHONE: 812-944-6733 FAX: 812-948-5047
e-Mail: info@SAMTEC.com code: 55322

DESCRIPTION:
TRUE 75 OHM STRAIGHT DIE CAST PLUG RG-6

DWG. NO.
BNC7T-P-C-XX-ST-CA6DX

BY: T. MEEK 11/17/2009 SHEET 2 OF 2