

**ALL DIMENSIONS ARE REFERENCE
(SEE XC-169-XX-XX-X-XX FOR CONTROLLING PRINT)**

DO NOT SCALE FROM THIS PRINT

CC69X-XXXX-01-X-XX

SUPPLIED
-L: LOOSE
-R: REEL

LEAD STYLE
-2024 (20-24 AWG)
-1620 (16-20 AWG)
-2426 (24-26 AWG)(PTFE)

OPTION
(INSULATION THICKNESS)
-01

MATERIAL SPECIFICATION
-SP: STANDARD POWER
*-HP: HIGH POWER

PLATING
-T: MATTE TIN

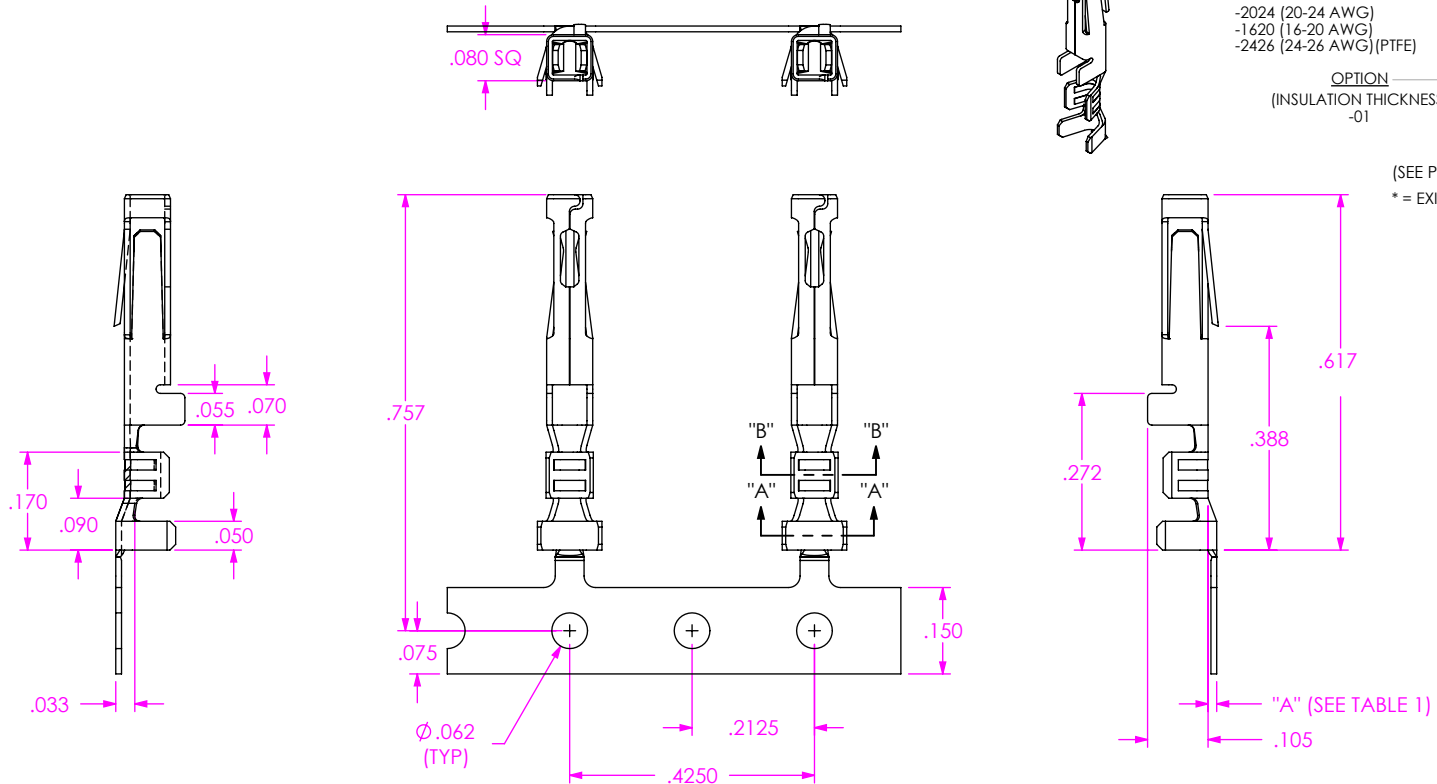
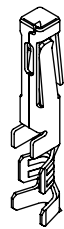

(SEE PP-C-169-XX-XX-X FOR PLATING INSTRUCTIONS)
* = EXISTING CUSTOMERS ONLY AS OF REV P

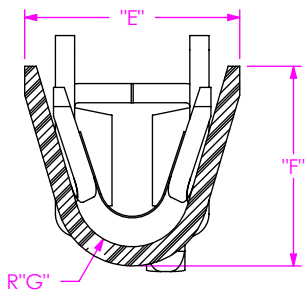

SECTION "A"-"A"
SCALE 10 : 1

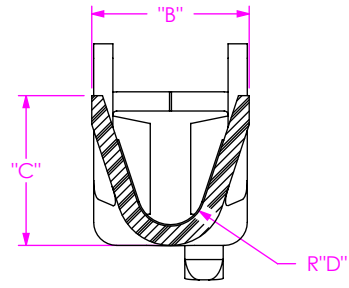

SECTION "B"-"B"
SCALE 10 : 1

FIG 1
(CC69X-XXXX-01-X-XX SHOWN)

- NOTES:
1. PLATED XC-169 PARTS TO BE PULLED, PLATING OPTION CONFIRMED, POSITIONED AS SHOWN ON SAMTEC REEL WITH VIEWPORTS, LABELED CC69R WITH APPROPRIATE PLATING CALLOUT AND LABEL PLACED AS SHOWN.
 2. MAXIMUM NO OF SPLICES PER REEL: 2.
 3. SPLICES ARE NOT TO BE CONNECTED.
 4. NUMBER OF SPLICES TO BE MARKED ON EACH REEL.
 5. REELED PARTS TO BE INTERLEAVED WITH PAPER BETWEEN EACH LAYER OF PARTS.
 6. ALLOWABLE INTERLEAF SPLICES PER REEL: 3.
 7. SECURELY CONNECT INTERLEAF SPLICE.
 8. OUTER WRAP SHALL RECEIVE PROTECTIVE REEL BAND PER BELOW: RB-24-1.00-P.
 9. DUE TO PLATING REQUIREMENTS CONTACT SAMPLES MAY BE REMOVED INTERMITTINGLY FROM THE CARRIER RESULTING IN SMALL GAPS BUT DOES NOT AFFECT FINAL COUNT.
 10. QTY PER REEL: 4,000 +100/-0 PCS.

UNLESS OTHERWISE SPECIFIED, DIMENSIONS ARE IN INCHES.
TOLERANCES ARE:
DECIMALS ANGLES

PROPRIETARY NOTE
* THIS DOCUMENT CONTAINS CONFIDENTIAL AND PROPRIETARY INFORMATION AND ALL DESIGN, MANUFACTURING, REPRODUCTION, USE, PATENT RIGHTS AND SALES RIGHTS ARE EXPRESSLY RESERVED BY SAMTEC, INC. THIS DOCUMENT SHALL NOT BE DISCLOSED, IN WHOLE OR PART, TO ANY UNAUTHORIZED PERSON OR ENTITY NOR REPRODUCED, TRANSFERRED OR INCORPORATED IN ANY OTHER PROJECT IN ANY MANNER WITHOUT THE EXPRESS WRITTEN CONSENT OF SAMTEC, INC.



520 PARK EAST BLVD. NEW ALBANY, IN 47150
PHONE: 812-944-6733 FAX: 812-948-5047
e-Mail: info@SAMTEC.com code 55322

TABLE 1									
STYLE	"A"	"B"	"C"	"D"	"E"	"F"	"G"	"H"	"J"
-2024	.015	.082	.078	.018	.112	.104	.030	.005	30
-1620	.025	.110	.115	.025	.184	.168	.055	.005	30
-2426	.015	.082	.078	.018	.080	.067	.020	.005	30

MATERIAL: DO NOT SCALE DRAWING SHEET SCALE: 3:1
-SP: PHOS BRONZE
-HP: HIGH COPPER ALLOY

THICKNESS: .0100

DESCRIPTION: .165 IPBD CONTACT

DWG. NO. CC69X-XXXX-01-X-XX

BY: BRATCHER 10/7/04 SHEET 1 OF 2

P/N	AWG	PULL FORCE LBS	STRANDS / AWG	INSULATION OD	"K"	"L"	"M"	"R" MAX (VESTIGE LENGTH)	"S" MAX (TAB LENGTH)
CC69X-2024-X	24	5	7/32	0.053-0.059	.0360	.0580	.128	.0020	.0200
	22	8	7/30	0.059-0.065	.0390	.0580	.128	.0020	.0200
	20	13	7/28	0.0660-0.0720	.0410	.0580	.128	.0020	.0200
CC69X-1620-X	20	13	7/28	0.097-0.103	.0470	.0740	.115	.0020	.0200
	18	20	16/30	0.107-0.113	.0520	.0740	.115	.0020	.0200
	16	30	26/30	0.121-0.125	.0620	.0740	.128	.0020	.0200
CC69X-2426-X	24TC	5	7/32	0.041-0.047	.0380	.0580	.128	.0020	.0200

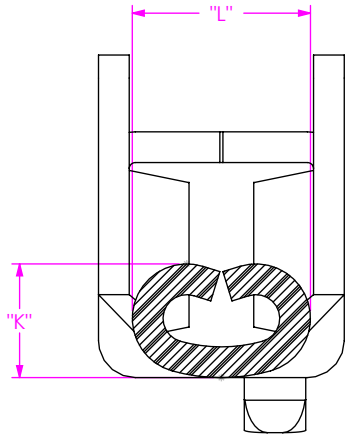

WIRE CRIMP
SCALE 16 : 1

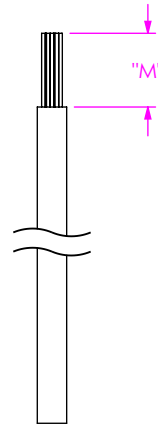

INSULATOR STRIP LENGTH
FIG 2
RECOMENDED PROCESSING

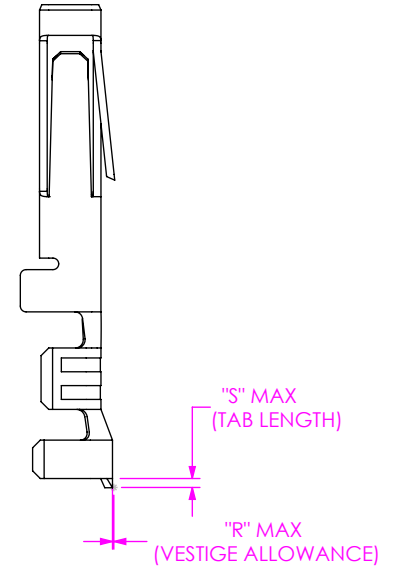

CARRIER TAB SPECIFICATION
SCALE 4 : 1

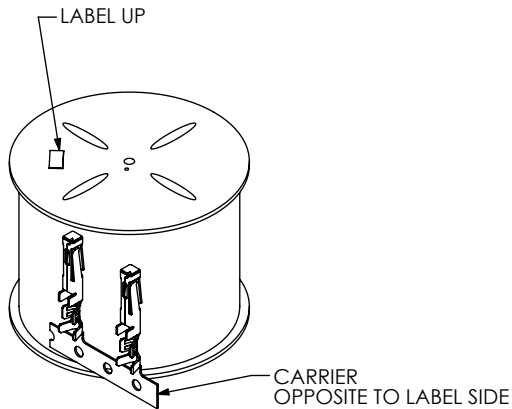
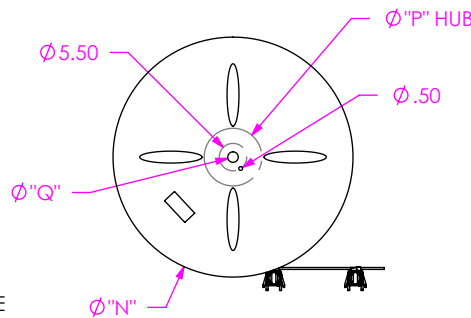

FIG 3
REEL SPECIFICATIONS

UNWINDING DIRECTION



SUPPLIED	REEL PART NUMBER	"N"	"P"	"Q"
-R	R-24-08.00-1.00-P	24.00	8.000	1.125

PROPRIETARY NOTE
THIS DOCUMENT CONTAINS CONFIDENTIAL AND PROPRIETARY INFORMATION AND ALL DESIGN, MANUFACTURING, REPRODUCTION, USE, PATENT RIGHTS AND SALES RIGHTS ARE EXPRESSLY RESERVED BY SAMTEC, INC. THIS DOCUMENT SHALL NOT BE DISCLOSED, IN WHOLE OR IN PART, TO ANY UNAUTHORIZED PERSON OR ENTITY NOR REPRODUCED, TRANSFERRED OR INCORPORATED IN ANY OTHER PROJECT IN ANY MANNER WITHOUT THE EXPRESS WRITTEN CONSENT OF SAMTEC, INC.

DO NOT SCALE DRAWING
SHEET SCALE: 3:1

samtec

520 PARK EAST BLVD, NEW ALBANY, IN 47150
PHONE: 812-944-6733 FAX: 812-948-5047
e-Mail info@SAMTEC.com code 55322

DESCRIPTION:
.165 IPBD CONTACT

DWG. NO. CC69X-XXXX-01-X-XX

BY: BRATCHER 10/7/04 SHEET 2 OF 2