

DESIGNED & DIMENSIONED
IN MILLIMETERS [INCHES]

DO NOT
SCALE FROM
THIS PRINT

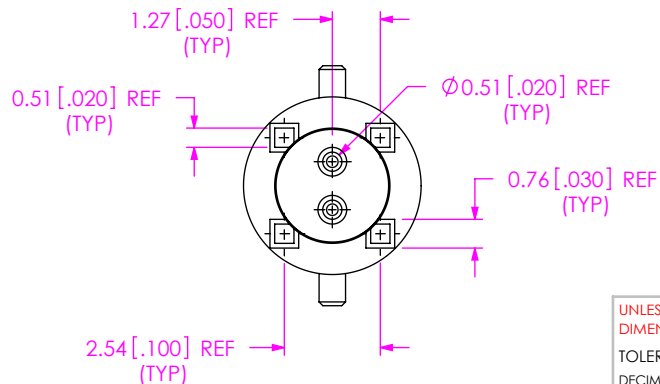
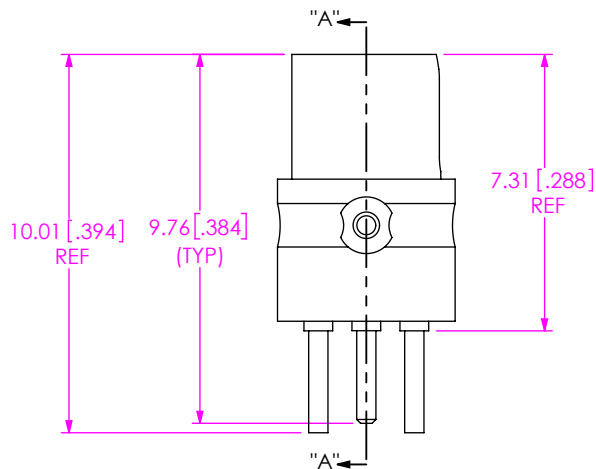
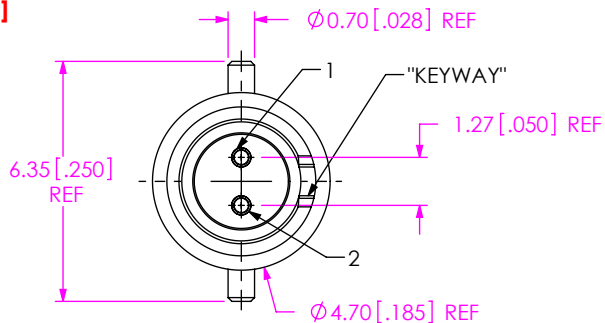

CJT-T-P-XX-ST-TH1

INTERFACE
-J: JACK

GENDER
-T: TERMINAL

TYPE
-P: PCB

TERMINATION
-TH1: THROUGH HOLE

ORIENTATION
-ST: STRAIGHT

PLATING SPECIFICATION
-HH: HEAVY GOLD / HEAVY GOLD
30µ" Au / 50µ" Ni MIN ON PIN
30µ" Au / 50µ" Ni MIN ON OUTER CONTACT
-GF: GOLD / FLASH GOLD
10µ" Au / 50µ" Ni MIN ON PIN
3µ" Au / 50µ" Ni MIN ON OUTER CONTACT
(SEE TABLE 1)

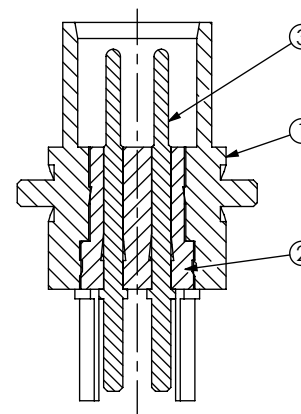

SECTION "A"-"A"

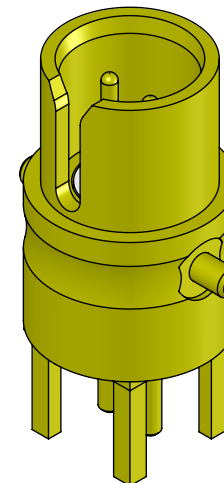

TABLE 1

ITEM	COMPONENT	-HH	-GF	QTY
1	SHELL	CJT-T-P-H-ST-TH1-SHL	CJT-T-P-F-ST-TH1-SHL	1
2	INSULATOR	CJT-INS-001		1
3	CONTACT	CJT-T-P-H-ST-TH1-PIN	CJT-T-P-G-ST-TH1-PIN	2

NOTES:

1. REPRESENTS A CRITICAL DIMENSION.
2. MINIMUM PUSHOUT FORCE FOR CENTER CONTACT: 7 N [1.57 LB].
INSULATOR: 20 N [4.5 LB].
3. PRODUCT TO BE PACKAGED PER PACKAGING STANDARD CO-HD-WI-3040-M.
TRAY: TY-SMA001-1,
COVER: TY-SMA001-2.

UNLESS OTHERWISE SPECIFIED,
DIMENSIONS ARE IN MILLIMETERS.

TOLERANCES ARE:

DECIMALS ANGLES
X.X: ±0.3 [.01] 5°
X.XX: ±0.13 [.005]
X.XXX: ±0.051 [.0020]

PROPRIETARY NOTE

THIS DOCUMENT CONTAINS CONFIDENTIAL AND PROPRIETARY INFORMATION AND ALL DESIGN, MANUFACTURING, REPRODUCTION, USE, PATENT RIGHTS AND SALES RIGHTS ARE EXPRESSLY RESERVED BY SAMTEC, INC. THIS DOCUMENT SHALL NOT BE DISCLOSED, IN WHOLE OR PART, TO ANY UNAUTHORIZED PERSON OR ENTITY NOR REPRODUCED, TRANSFERRED OR INCORPORATED IN ANY OTHER PROJECT IN ANY MANNER WITHOUT THE EXPRESS WRITTEN CONSENT OF SAMTEC, INC.

MATERIAL: DO NOT SCALE DRAWING SHEET SCALE: 5:1

CONTACT: PHOS BRONZE
OTHER METAL: BRASS
DIELECTRIC: PTFE



520 PARK EAST BLVD, NEW ALBANY, IN 47150
PHONE: 812-944-6733 FAX: 812-948-5047
e-Mail info@SAMTEC.com code 55322

DESCRIPTION:
STRAIGHT CIRCULAR JACK TWINAX

DWG. NO.
CJT-T-P-XX-ST-TH1

BY: ALVIN W 12/03/2010 SHEET 1 OF 3

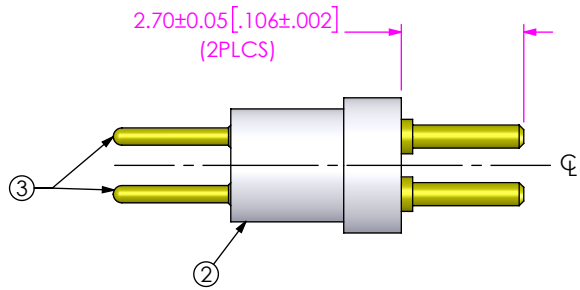

IN-PROCESS 1
INSERT THE PINS TO THE INSULATOR

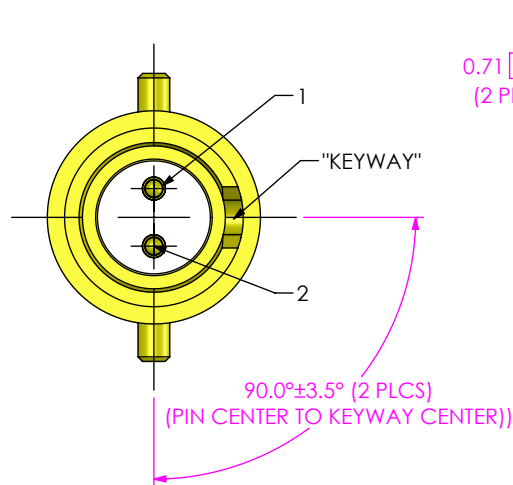

IN-PROCESS 2
INSERT THE PINS AND INSULATOR TO THE SHELL

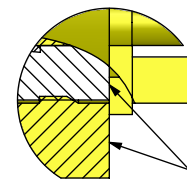
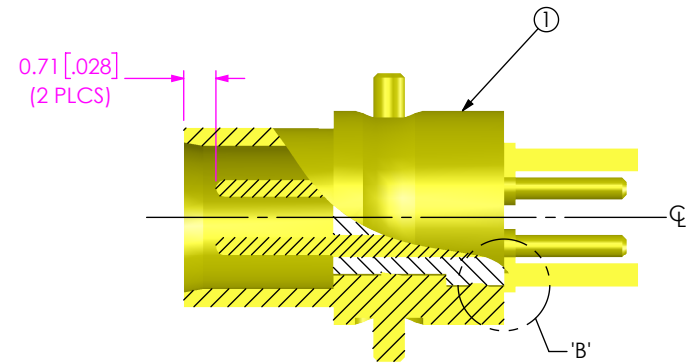

POSITION INSULATOR
FLUSH TO BODY +/-0.10

DETAIL 'B'
SCALE 12 : 1

CRITICAL DIMENSION INSPECTION INSTRUCTION TABLE

ASSEMBLY OPERATION	IN-PROCESS INSPECTION
INSERT THE PINS TO THE INSULATOR	C1
INSERT THE PINS AND INSULATOR TO THE SHELL	C2, C3, C4

PROPRIETARY NOTE

THIS DOCUMENT CONTAINS CONFIDENTIAL AND PROPRIETARY INFORMATION AND ALL DESIGN, MANUFACTURING, REPRODUCTION, USE, PATENT RIGHTS AND SALES RIGHTS ARE EXPRESSLY RESERVED BY SAMTEC, INC. THIS DOCUMENT SHALL NOT BE DISCLOSED, IN WHOLE OR PART, TO ANY UNAUTHORIZED PERSON OR ENTITY NOR REPRODUCED, TRANSFERRED OR INCORPORATED IN ANY OTHER PROJECT IN ANY MANNER WITHOUT THE EXPRESS WRITTEN CONSENT OF SAMTEC, INC.



520 PARK EAST BLVD, NEW ALBANY, IN 47150
PHONE: 812-944-6733 FAX: 812-948-5047
e-Mail: info@SAMTEC.com code 53322

SHEET SCALE: 5:1

DESCRIPTION:
STRAIGHT CIRCULAR JACK TWINAX

DWG. NO.
CJT-T-P-XX-ST-TH1

BY: ALVIN W 12/03/2010 SHEET 2 OF 3

RECOMMENDED PCB LAYOUT

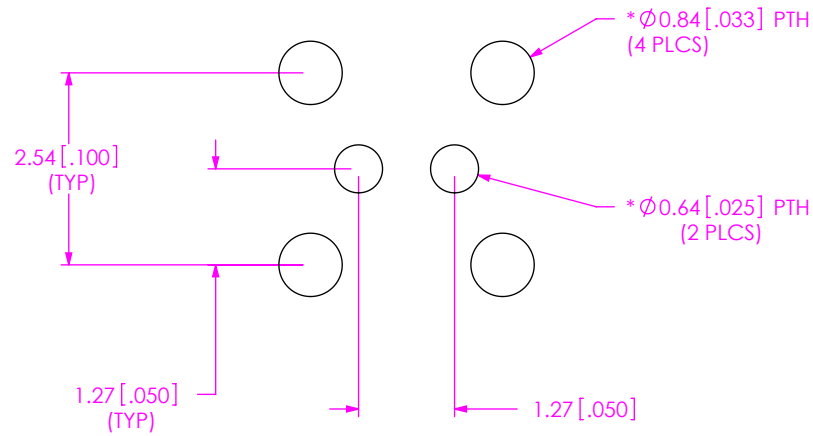

* TO BE SOLDERED USING PASTE-IN-HOLE TECHNOLOGY.

RECOMMENDED STENCIL LAYOUT

NOTE: STENCIL TO BE .152 [.0060] THICK

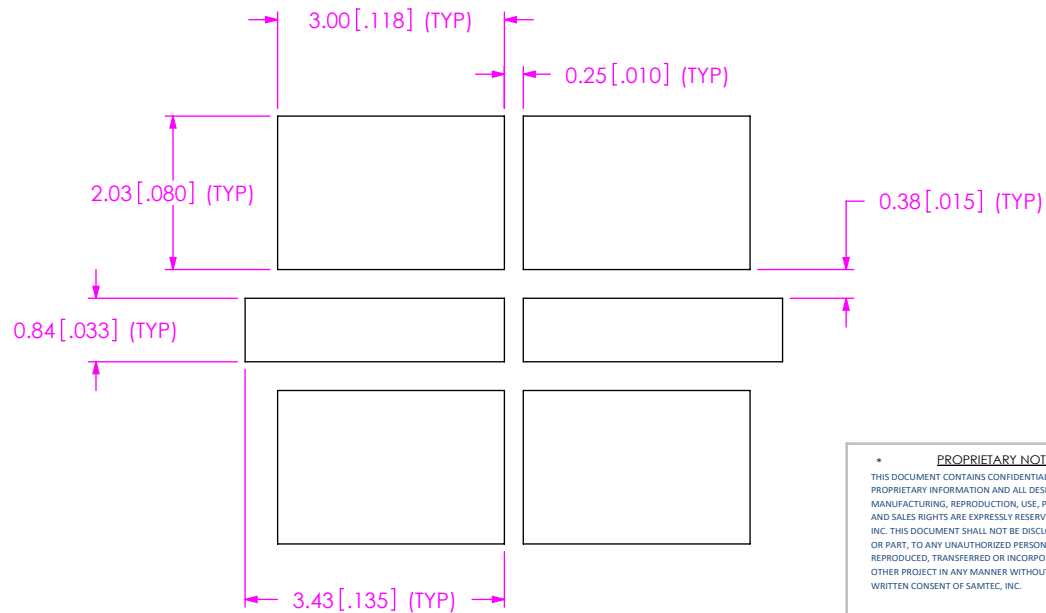

PROPRIETARY NOTE
 THIS DOCUMENT CONTAINS CONFIDENTIAL AND PROPRIETARY INFORMATION AND ALL DESIGN, MANUFACTURING, REPRODUCTION, USE, PATENT RIGHTS AND SALES RIGHTS ARE EXPRESSLY RESERVED BY SAMTEC, INC. THIS DOCUMENT SHALL NOT BE DISCLOSED, IN WHOLE OR PART, TO ANY UNAUTHORIZED PERSON OR ENTITY NOR REPRODUCED, TRANSFERRED OR INCORPORATED IN ANY OTHER PROJECT IN ANY MANNER WITHOUT THE EXPRESS WRITTEN CONSENT OF SAMTEC, INC.

DO NOT SCALE DRAWING

SHEET SCALE: 10:1



520 PARK EAST BLVD, NEW ALBANY, IN 47150
 PHONE: 812-944-6733 FAX: 812-948-5047
 e-Mail info@SAMTEC.com code 55322

DESCRIPTION:
 STRAIGHT CIRCULAR JACK TWINAX

DWG. NO.
 CJT-T-P-XX-ST-TH1

BY: ALVIN W 12/03/2010 SHEET 3 OF 3