

DESIGNED AND DIMENSIONED IN MILLIMETERS[INCHES]
ALL DIMENSIONS REFERENCE EXCEPT AS SHOWN

CPI-16-XX-2-X-RA-0-L-XR

DO NOT SCALE FROM THIS PRINT

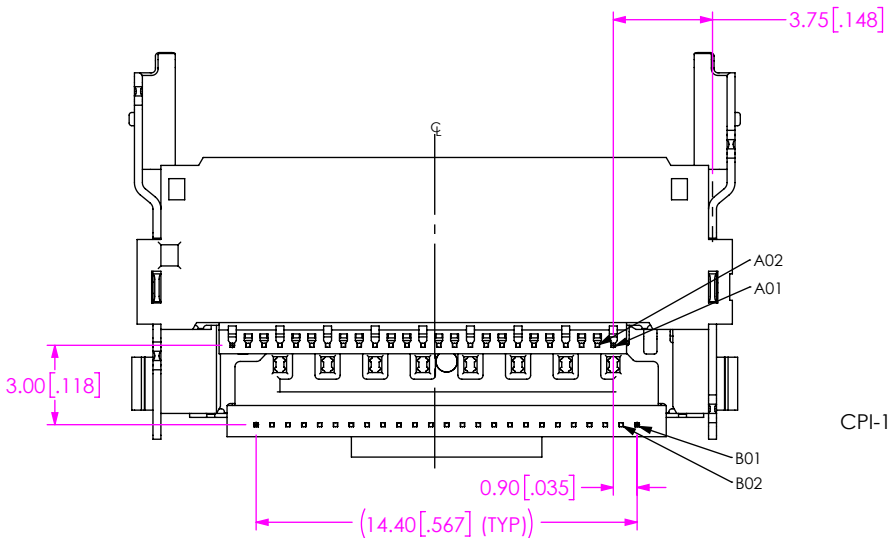
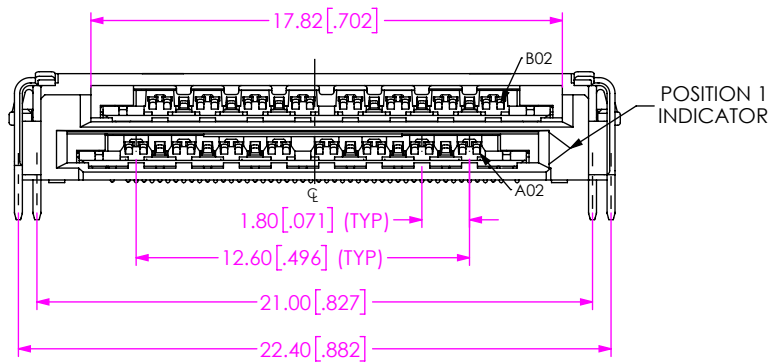
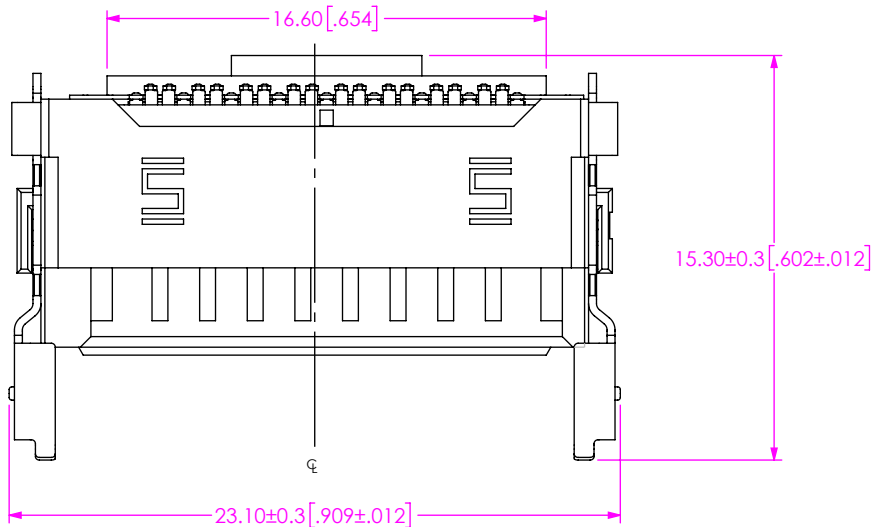
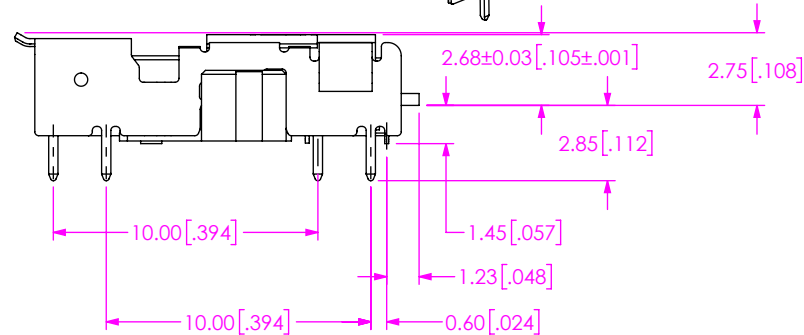
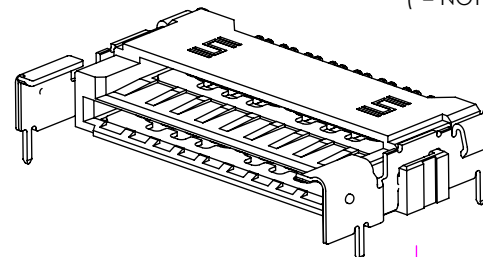

FIG 1
CPI-16-01-2-X-RA-0-L-XR SHOWN

- No. OF PAIRS
- LEAD STYLE
 - 01: SURFACE MOUNT
- ROW SPECIFICATION
 - 2: 2 ROW 16 PAIRS
- PLATING SPECIFICATION
 - S: 30µ" GOLD IN CONTACT AREA, TIN ON TAIL
- TAPE & REEL (SEE NOTE 3 & 4)
 - TR: TAPE & REEL
 - FR: FULL REEL QTY TAPE & REEL
- LATCHING
- RIGHT ANGLE
 - RA: RIGHT ANGLE

(* = NOT TOOLED)



NOTES:

1. MINIMUM PUSHOUT FORCE: 1.6N[0.36 LB].
2. TAPE & REEL IS STANDARD PACKAGING.
3. ORDERS WILL BE PACKAGED ACCORDING TO THE SAMTEC PACKAGING EFFICIENCY STANDARDS (SPES) FOUND ON WWW.SAMTEC.COM.
4. ATTACH LABEL -4x2 TO EACH REEL.

<p>PROPRIETARY NOTE THIS DOCUMENT CONTAINS CONFIDENTIAL AND PROPRIETARY INFORMATION AND ALL DESIGN, MANUFACTURING, REPRODUCTION, USE, PATENT RIGHTS AND SALES RIGHTS ARE EXPRESSLY RESERVED BY SAMTEC, INC. THIS DOCUMENT SHALL NOT BE DISCLOSED, IN WHOLE OR PART, TO ANY UNAUTHORIZED PERSON OR ENTITY NOR REPRODUCED, TRANSFERRED OR INCORPORATED IN ANY OTHER PROJECT IN ANY MANNER WITHOUT THE EXPRESS WRITTEN CONSENT OF SAMTEC, INC.</p>		 520 PARK EAST BLVD., NEW ALBANY, IN 47150 PHONE: 812-944-6733 FAX: 812-948-5047 e-Mail: info@SAMTEC.com code 55322
<p>MATERIAL: SHEET SCALE: 1:2 DO NOT SCALE DRAWING</p>	<p>DESCRIPTION: 0.6MM CHIP PACKAGE INTERCONNECT ASSY</p>	
<p>INSULATOR: LCP, COLOR: BLACK CONTACT: COPPER ALLOY WELD TAB: COPPER ALLOY</p>	<p>DWG. NO. CPI-16-XX-2-X-RA-0-L-XR</p>	
<p>BY: KNOWLDEN 1/24/2019</p>		<p>SHEET 1 OF 1</p>