

DESIGNED & DIMENSIONED
IN MILLIMETERS [INCHES]

DCA-ACR-22-P-X

SIZE ———
PLASTIC ———

KEYING FEATURE COLOR
-1: ORANGE
-2: GREEN
-3: BLUE
-4: YELLOW

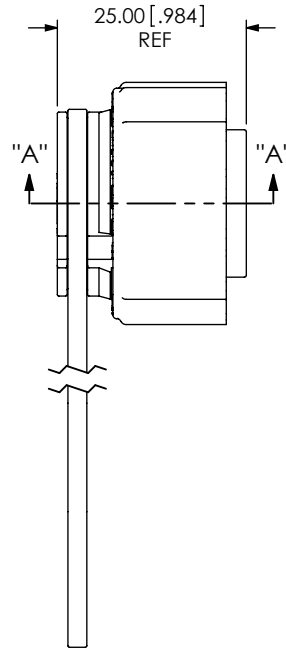
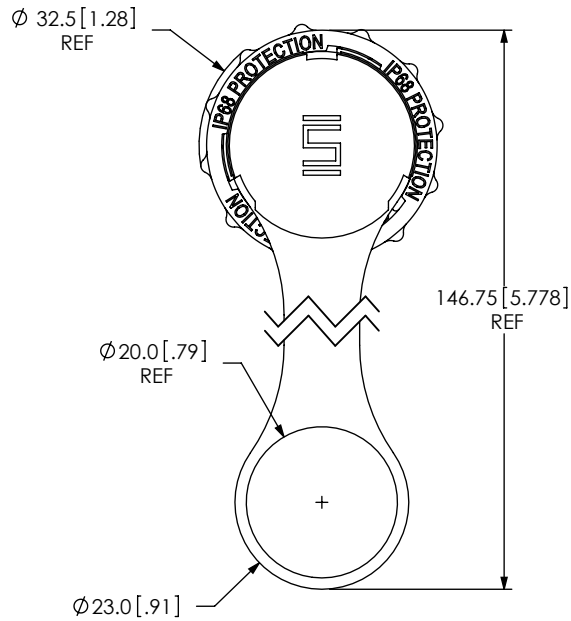

IN-PROCESS
PUSH ACCL-22-P OVER DC-ACR-22-P UNTIL IT SNAPS INTO PLACE AGAINST FLANGE. STRETCH ACCL-22-X OVER DC-ACR-22-P UNTIL IT SEATS IN GROOVE.

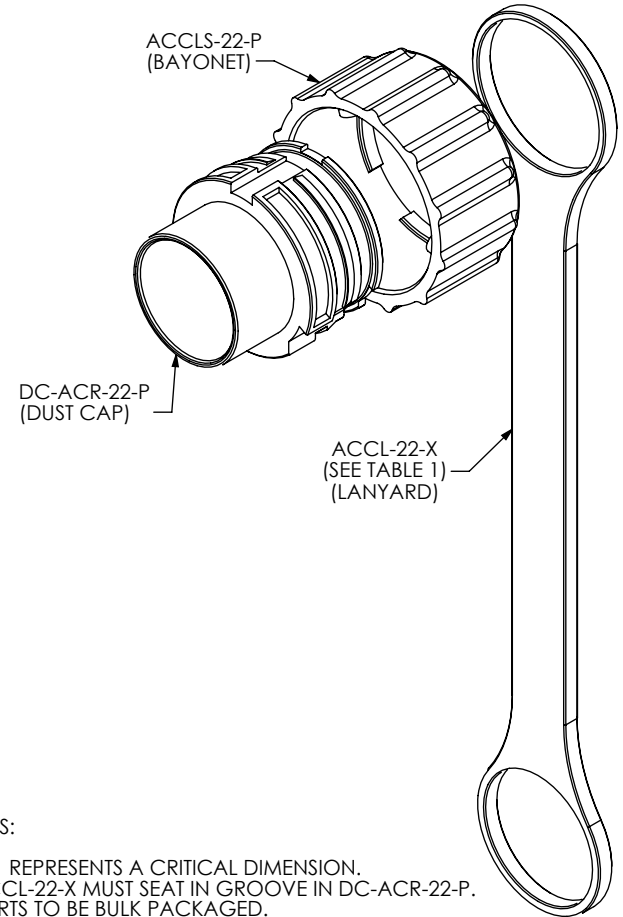

DO NOT
SCALE FROM
THIS PRINT

APPLICATION VIEW

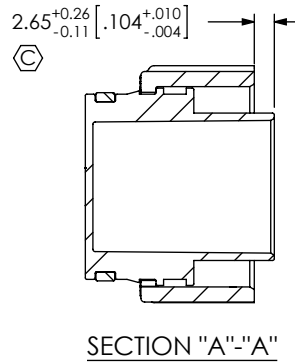
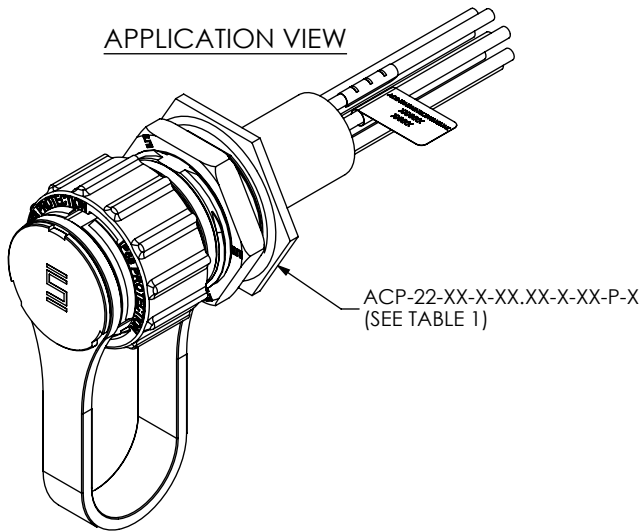

NOTES:

1. $\text{\textcircled{C}}$ REPRESENTS A CRITICAL DIMENSION.
2. ACCL-22-X MUST SEAT IN GROOVE IN DC-ACR-22-P.
3. PARTS TO BE BULK PACKAGED.

CORRESPONDING CABLE PART NUMBER	KEYING FEATURE COLOR	ACCL-22-X
ACP-22-XX-X-XX.XX-X-XX-P-1	-1	ACCL-22-1
ACP-22-XX-X-XX.XX-X-XX-P-2	-2	ACCL-22-2
ACP-22-XX-X-XX.XX-X-XX-P-3	-3	ACCL-22-3
ACP-22-XX-X-XX.XX-X-XX-P-4	-4	ACCL-22-4

UNLESS OTHERWISE SPECIFIED, DIMENSIONS ARE IN MILLIMETERS. TOLERANCES ARE:
DECIMALS ANGLES
X.X: ± 0.3 [.01] 2°
X.XX: ± 0.13 [.005]
X.XXX: ± 0.051 [.0020]

PROPRIETARY NOTE

THIS DOCUMENT CONTAINS INFORMATION CONFIDENTIAL AND PROPRIETARY TO SAMTEC, INC. AND SHALL NOT BE REPRODUCED OR TRANSFERRED TO OTHER DOCUMENTS OR DISCLOSED TO OTHERS OR USED FOR ANY PURPOSE OTHER THAN THAT WHICH IT WAS OBTAINED WITHOUT THE EXPRESSED WRITTEN CONSENT OF SAMTEC, INC.



520 PARK EAST BLVD, NEW ALBANY, IN 47150
PHONE: 812-944-6733 FAX: 812-948-5047
e-Mail: info@SAMTEC.com code 53322

MATERIAL: DO NOT SCALE DRAWING SHEET SCALE: 1:1

DC-22-P-P: NYLON, COLOR: BLACK
ACCLS-22-P: NYLON, COLOR: BLACK
ACCL-22-X: SILICONE

DESCRIPTION:
ACCLIMATE CIRC. PANEL DUST CAP

DWG. NO. DCA-ACR-22-P-X

BY: VICKY Z 10/11/2010 SHEET 1 OF 1