

DO NOT
SCALE FROM
THIS PRINT

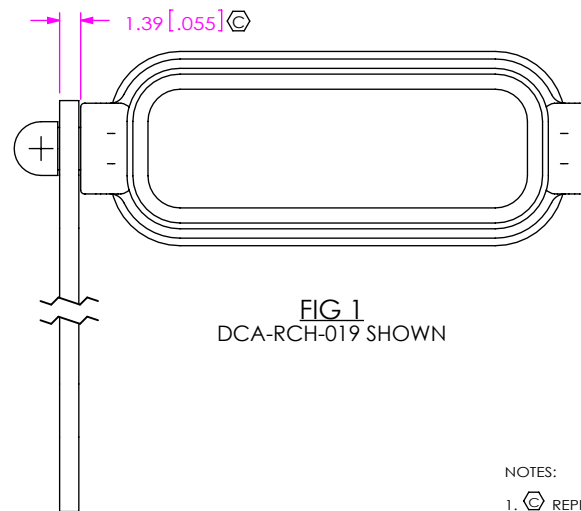
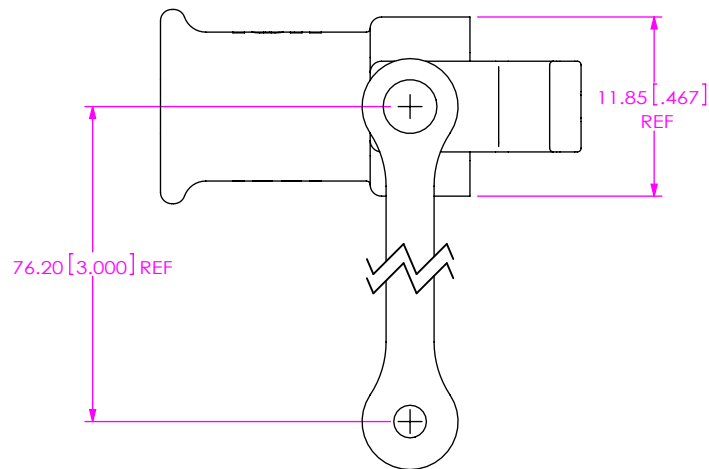
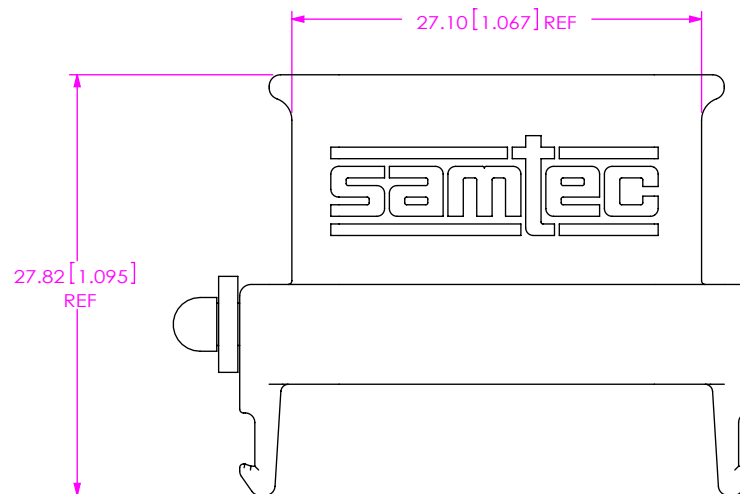
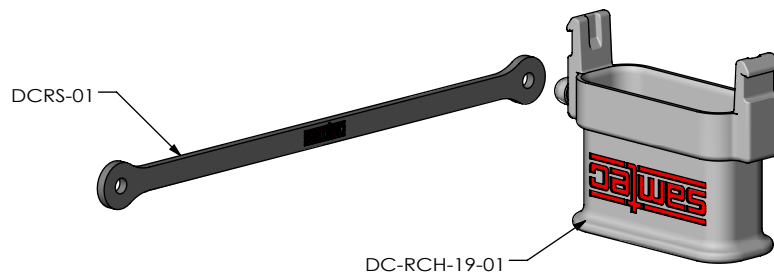

FIG 1
DCA-RCH-019 SHOWN

NOTES:

1. Ⓢ REPRESENTS A CRITICAL DIMENSION.
2. COMPONENTS OF SUB-ASSEMBLY TO BE INSPECTED USING COMPONENT PRINTS.
3. MINIMUM RETENTION: 4.4N [1.0 LB].
4. PARTS TO BE BULK PACKAGED.



UNLESS OTHERWISE SPECIFIED,
DIMENSIONS ARE IN MILLIMETERS.
TOLERANCES ARE:
DECIMALS ANGLES
X.X: ± 0.3 [.01] 2°
X.XX: ± 0.13 [.005]
X.XXX: ± 0.051 [.0020]

PROPRIETARY NOTE

THIS DOCUMENT CONTAINS INFORMATION CONFIDENTIAL AND PROPRIETARY TO SAMTEC, INC. AND SHALL NOT BE REPRODUCED OR TRANSFERRED TO OTHER DOCUMENTS OR DISCLOSED TO OTHERS OR USED FOR ANY PURPOSE OTHER THAN THAT WHICH IT WAS OBTAINED WITHOUT THE EXPRESSED WRITTEN CONSENT OF SAMTEC, INC.



520 PARK EAST BLVD, NEW ALBANY, IN 47150
PHONE: 812-944-6733 FAX: 812-948-5047
e-Mail: info@SAMTEC.com code 55322

MATERIAL: DO NOT SCALE DRAWING SHEET SCALE: 2:1
DUST CAP: PA 66 RG201 BK
STRAP: RUBBER

DESCRIPTION:	DUST CAP FOR RCH
DWG. NO.	DCA-RCH-019
BY: D.SCHMELZ 07/22/2010	SHEET 1 OF 1