

DO NOT SCALE FROM THIS PRINT

DESIGNED & DIMENSIONED IN MILLIMETERS [INCHES]

DCA-RPBE-XX-01-P

No OF PORTS

-01: 1 PORT (SEE SHT 1)
-02: 2 PORT (SEE SHT 2)

OPTION 2

-P: PUSH ON/
NON-LATCHING

OPTION

-01: W/STRAP

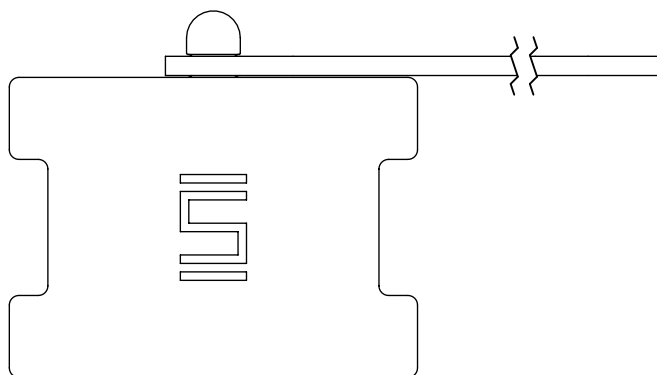
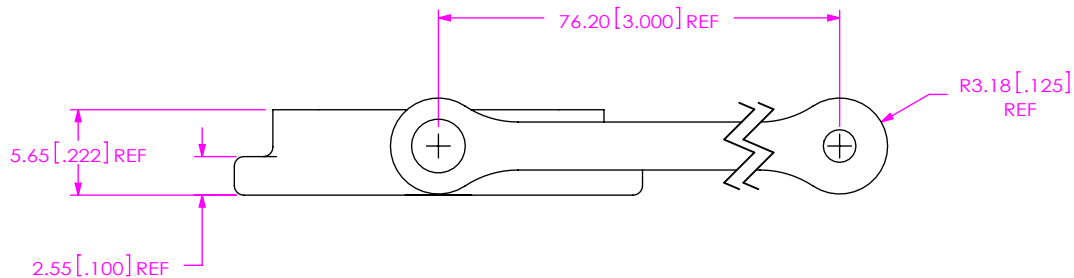
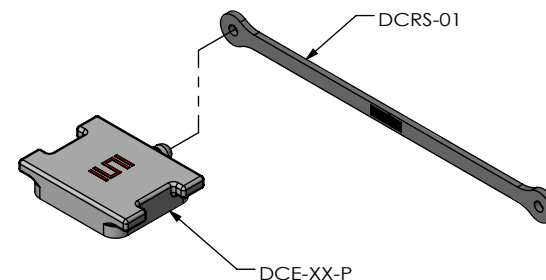
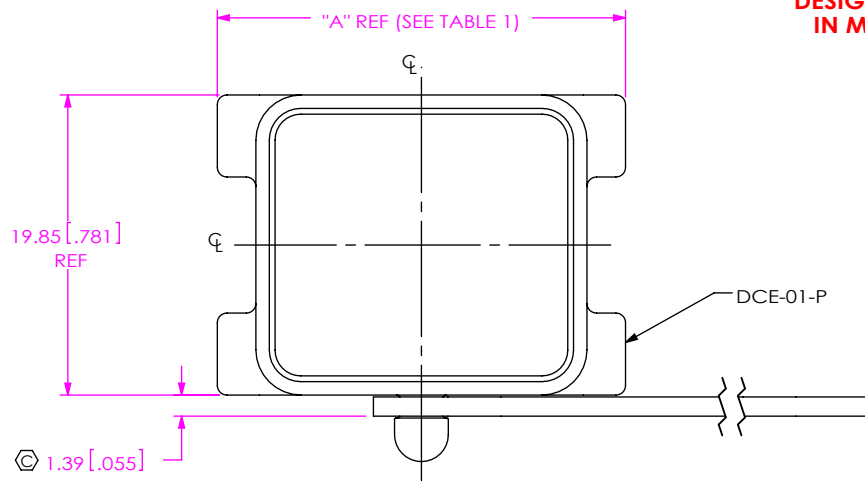

PORTS	"A"
-01	27.00 [1.063]
-02	44.70 [1.760]

FIG. 1
DCA-RPBE-01-01-P SHOWN

NOTES:

1. Ⓢ REPRESENTS A CRITICAL DIMENSION.
2. COMPONENTS OF SUB-ASSEMBLY TO BE INSPECTED USING COMPONENT PRINTS.
3. MINIMUM RETENTION: 4.4N [1.0 LB.].
4. PARTS TO BE BULK PACKAGED.

UNLESS OTHERWISE SPECIFIED, DIMENSIONS ARE IN MILLIMETERS. TOLERANCES ARE:
DECIMALS ANGLES
X.X: ±0.3 [.01] 2°
X.XX: ±0.13 [.005]
X.XXX: ±0.051 [.0020]

PROPRIETARY NOTE
THIS DOCUMENT CONTAINS CONFIDENTIAL AND PROPRIETARY INFORMATION AND ALL DESIGN, MANUFACTURING, REPRODUCTION, USE, PATENT RIGHTS AND SALES RIGHTS ARE EXPRESSLY RESERVED BY SAMTEC, INC. THIS DOCUMENT SHALL NOT BE DISCLOSED, IN WHOLE OR PART, TO ANY UNAUTHORIZED PERSON OR ENTITY NOR REPRODUCED, TRANSFERRED OR INCORPORATED IN ANY OTHER PROJECT IN ANY MANNER WITHOUT THE EXPRESS WRITTEN CONSENT OF SAMTEC, INC.

MATERIAL: DO NOT SCALE DRAWING SHEET SCALE: 2:1
CAP: PA66
STRAP: EPDM



520 PARK EAST BLVD, NEW ALBANY, IN 47150
PHONE: 812-944-6733 FAX: 812-948-5047
e-Mail: info@SAMTEC.com code 55322

DESCRIPTION: DUST CAP ASM FOR RPBE/SPE

DWG. NO. DCA-RPBE-XX-01-P

BY: ROY LUO 9/21/2010 SHEET 1 OF 2

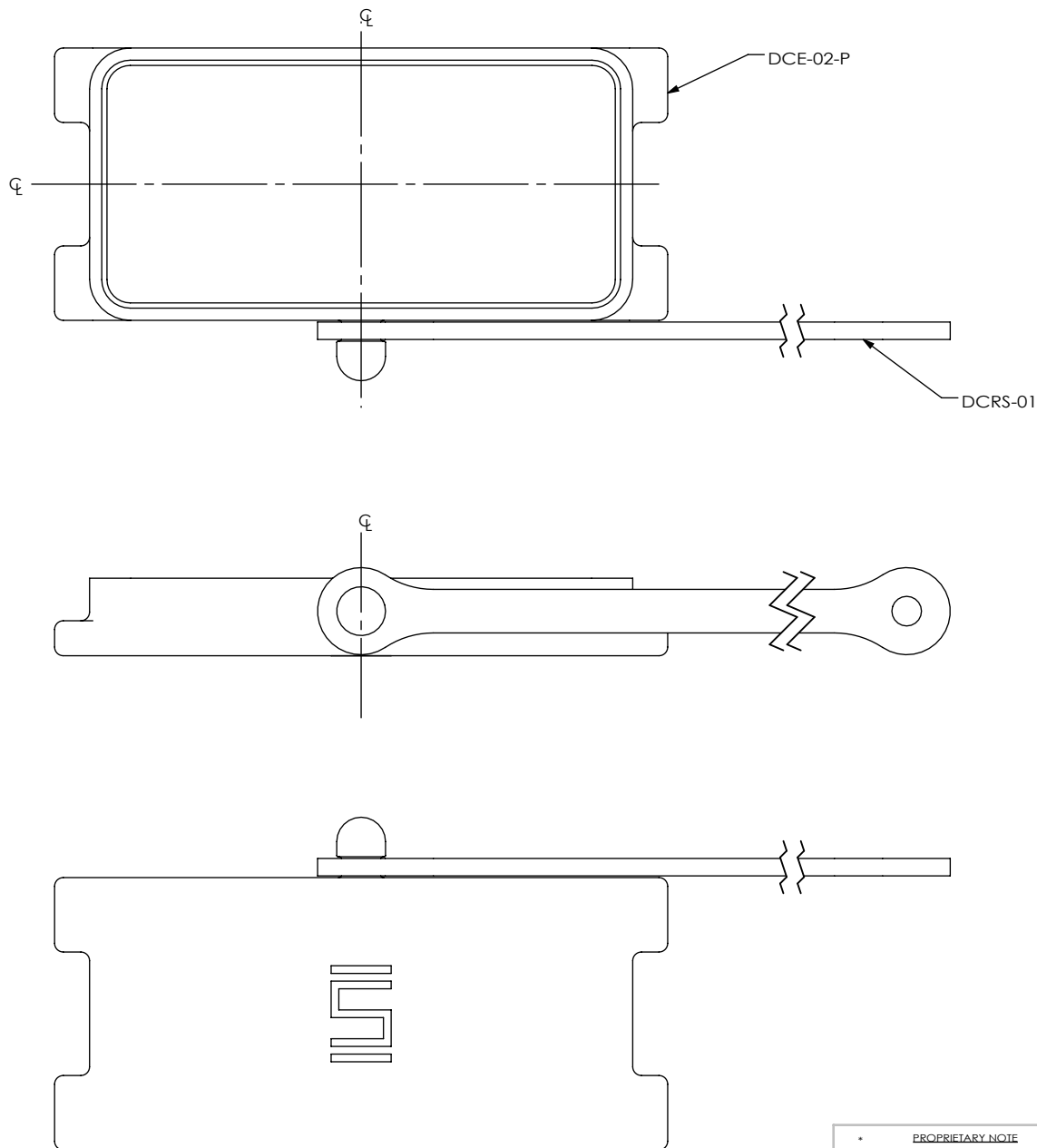

FIG. 2
DCA-RPBE-02-01-P SHOWN
(SAME AS FIG. 1, DIFFERENT AS SHOWN)

PROPRIETARY NOTE
 THIS DOCUMENT CONTAINS CONFIDENTIAL AND PROPRIETARY INFORMATION AND ALL DESIGN, MANUFACTURING, REPRODUCTION, USE, PATENT RIGHTS AND SALES RIGHTS ARE EXPRESSLY RESERVED BY SAMTEC, INC. THIS DOCUMENT SHALL NOT BE DISCLOSED, IN WHOLE OR PART, TO ANY UNAUTHORIZED PERSON OR ENTITY NOR REPRODUCED, TRANSFERRED OR INCORPORATED IN ANY OTHER PROJECT IN ANY MANNER WITHOUT THE EXPRESS WRITTEN CONSENT OF SAMTEC, INC.

DO NOT SCALE DRAWING

SHEET SCALE: 2:1



520 PARK EAST BLVD, NEW ALBANY, IN 47150
 PHONE: 812-944-6733 FAX: 812-948-5047
 e-Mail info@SAMTEC.com code 55322

DESCRIPTION: DUST CAP ASM FOR RPBE/SPE

DWG. NO. DCA-RPBE-XX-01-P

BY: ROY LUO 9/21/2010 SHEET 2 OF 2