

DESIGNED AND DIMENSIONED IN MILLIMETERS [INCHES]
ALL DIMENSIONS REFERENCE EXCEPT AS SHOWN

EBTM-6-XX-2.0-X-RA-X-X-X

DO NOT SCALE FROM THIS PRINT

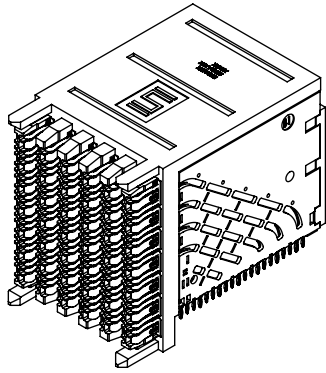

- No. OF PAIRS PER COLUMN
-6
 - COLUMNS
-06
-08
-10
-12
 - COLUMN PITCH
-2.0: 2.0 mm
 - PLATING SPECIFICATION
-S: 30µ" SELECTIVE GOLD IN CONTACT AREA, MATTE TIN ON TAIL
 - ORIENTATION
-RA: RIGHT ANGLE
 - KEYING
(ONLY AVAILABLE WITH -L OR -R GUIDANCE)
BLANK: NO KEYING
-A THRU -H: DENOTES POSITION OF FLAT ON KEY (SEE KEYING POSITION TABLE, SHT 4)
 - GUIDANCE
BLANK: NONE
-L: LEFT (SEE FIG 3, SHT 5)
-R: RIGHT (SEE FIG 2, SHT 4)
 - PIN CONFIGURATION (SEE NOTE 5)
-1: STANDARD
**-5: OPEN PIN FIELD
- (** = NOT RELEASED)

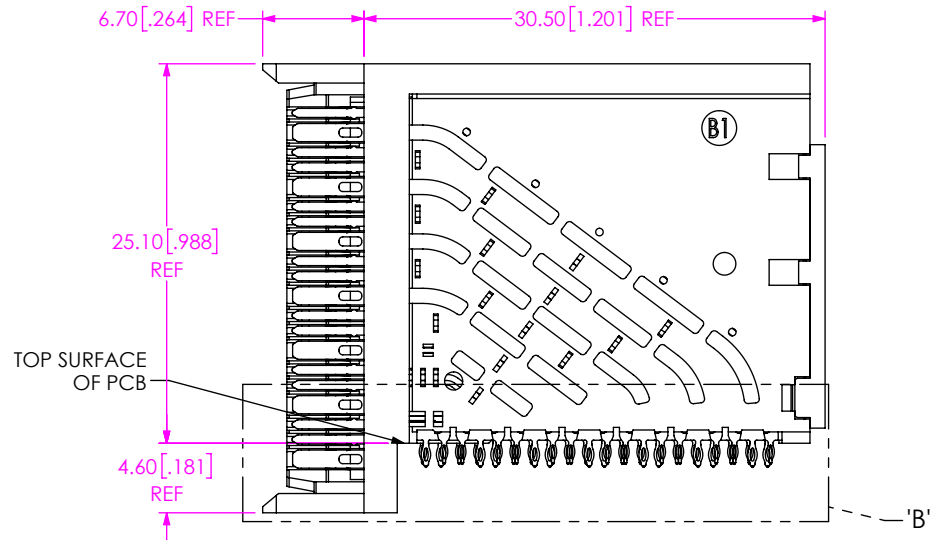
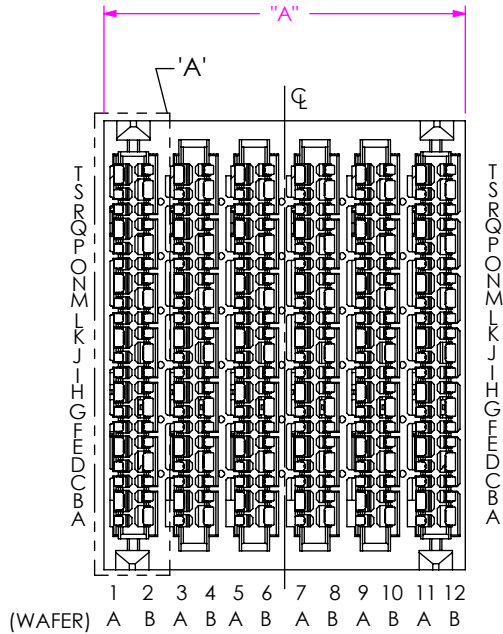
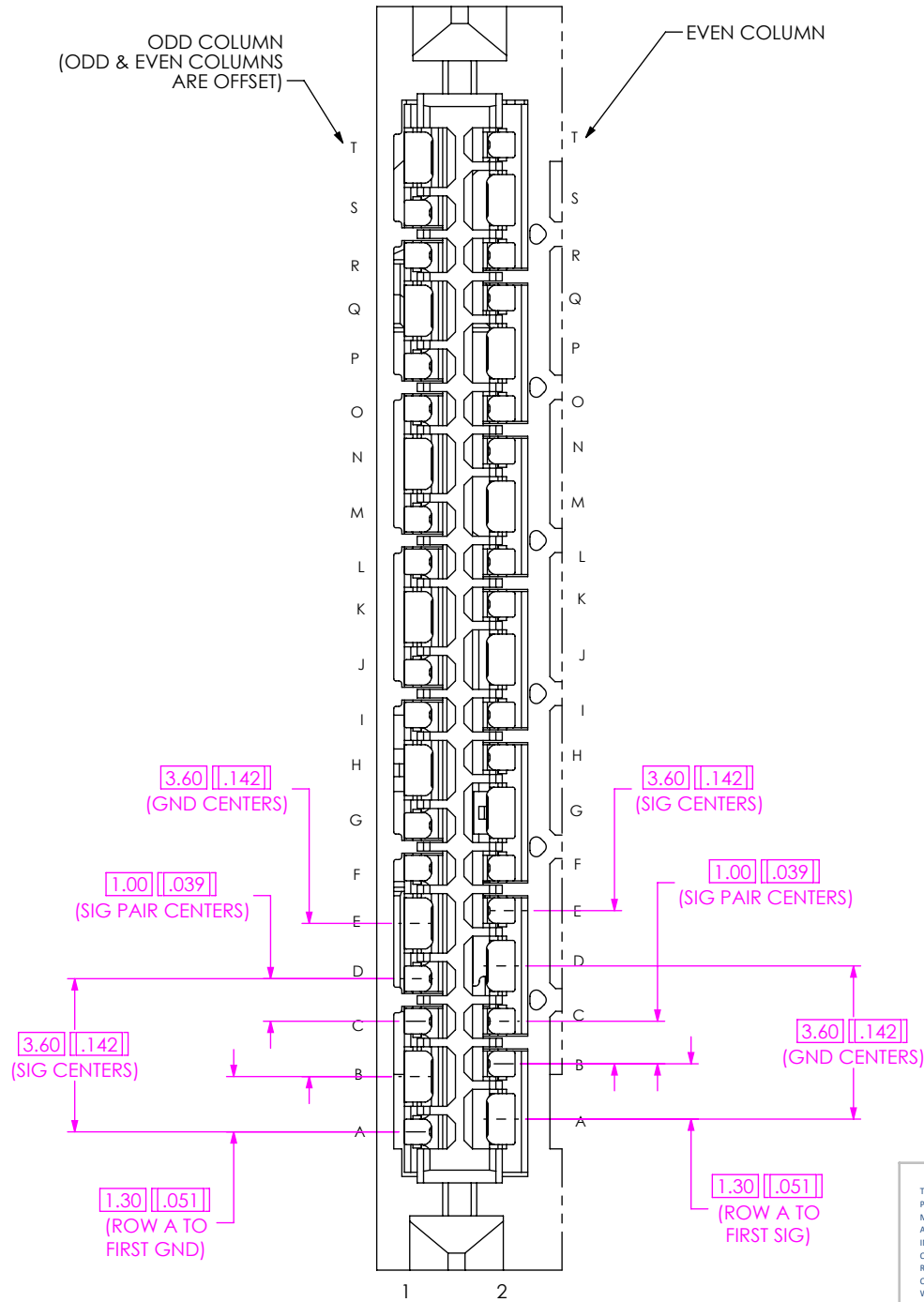

FIG 1
EBTM-6-12-2.0-X-RA-1 SHOWN

TABLE 1			
COLUMNS	"A"	"B"	"C"
-06	11.90 [0.469]	10.00 [0.394]	5.20 [0.205]
-08	15.90 [0.626]	14.00 [0.551]	7.20 [0.283]
-10	19.90 [0.783]	18.00 [0.709]	9.20 [0.362]
-12	23.90 [0.941]	22.00 [0.866]	11.20 [0.441]

- NOTES:
1. MINIMUM PUSHOUT FORCE: 2.22N [5 LB].
 2. CONTACT SAMTEC FOR CONNECTOR PRESS FIT INSTRUCTIONS.
 3. TRAYS TO BE STANDARD PACKAGING.
 4. ORDERS WILL BE PACKAGED ACCORDING TO THE SAMTEC PACKAGING EFFICIENCY STANDARDS (SPES) FOUND ON WWW.SAMTEC.COM.
 5. -1 STANDARD IS FOR DIFFERENTIAL PAIRS, SEE FOOTPRINT DRAWING FOR DETAILS.

<p>UNLESS OTHERWISE SPECIFIED, DIMENSIONS ARE IN MILLIMETERS [INCHES].</p> <p>TOLERANCES ARE:</p> <p>DECIMALS ANGLES</p> <p>X.X: ±0.3 [.01] 2°</p> <p>X.XX: ±0.10 [.004]</p> <p>X.XXX: ±0.050 [.0019]</p>	<p>PROPRIETARY NOTE</p> <p>THIS DOCUMENT CONTAINS CONFIDENTIAL AND PROPRIETARY INFORMATION AND ALL DESIGN, MANUFACTURING, REPRODUCTION, USE, PATENT RIGHTS AND SALES RIGHTS ARE EXPRESSLY RESERVED BY SAMTEC, INC. THIS DOCUMENT SHALL NOT BE DISCLOSED, IN WHOLE OR PART, TO ANY UNAUTHORIZED PERSON OR ENTITY NOR REPRODUCED, TRANSFERRED OR INCORPORATED IN ANY OTHER PROJECT IN ANY MANNER WITHOUT THE EXPRESS WRITTEN CONSENT OF SAMTEC, INC.</p>	<p>520 PARK EAST BLVD, NEW ALBANY, IN 47150 PHONE: 812-944-6733 FAX: 812-948-5047 e-Mail: info@SAMTEC.com code 53322</p>



DETAIL 'A'
SCALE 6 : 1

PROPRIETARY NOTE
 THIS DOCUMENT CONTAINS CONFIDENTIAL AND PROPRIETARY INFORMATION AND ALL DESIGN, MANUFACTURING, REPRODUCTION, USE, PATENT RIGHTS AND SALES RIGHTS ARE EXPRESSLY RESERVED BY SAMTEC, INC. THIS DOCUMENT SHALL NOT BE DISCLOSED, IN WHOLE OR PART, TO ANY UNAUTHORIZED PERSON OR ENTITY NOR REPRODUCED, TRANSFERRED OR INCORPORATED IN ANY OTHER PROJECT IN ANY MANNER WITHOUT THE EXPRESS WRITTEN CONSENT OF SAMTEC, INC.

DO NOT SCALE DRAWING

SHEET SCALE: 2:1



520 PARK EAST BLVD. NEW ALBANY, IN 47150
 PHONE: 812-944-6733 FAX: 812-948-5047
 e-Mail info@SAMTEC.com code 55322

DESCRIPTION:
 EXAMAX™ RIGHT ANGLE HEADER ASSEMBLY

DWG. NO.
 EBTM-6-XX-2.0-X-RA-X-X-X

BY: B BLESSING 9/5/17 SHEET 2 OF 6

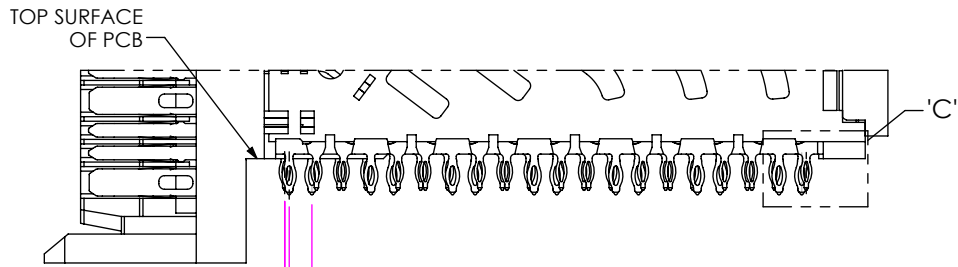

1.200 [.0472] (TYP)
 3.90 [.154]
 4.10 [.161]

DETAIL 'B'

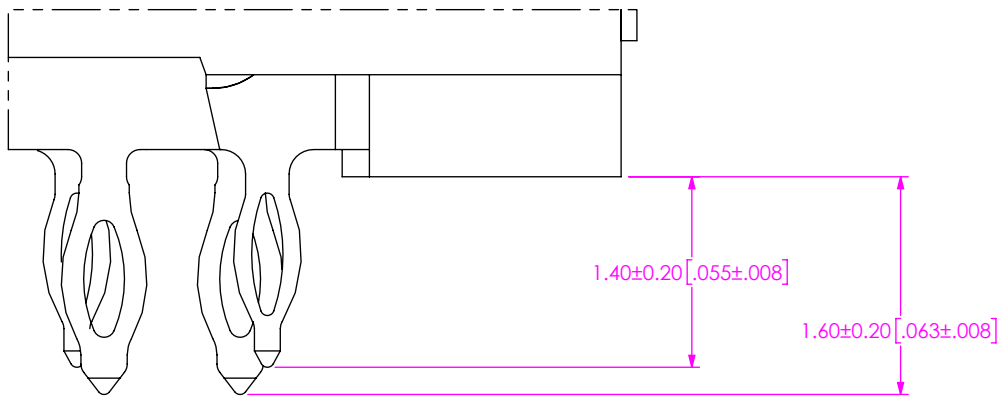

1.40±0.20 [.055±.008]
 1.60±0.20 [.063±.008]

DETAIL 'C'
 SCALE 18:1

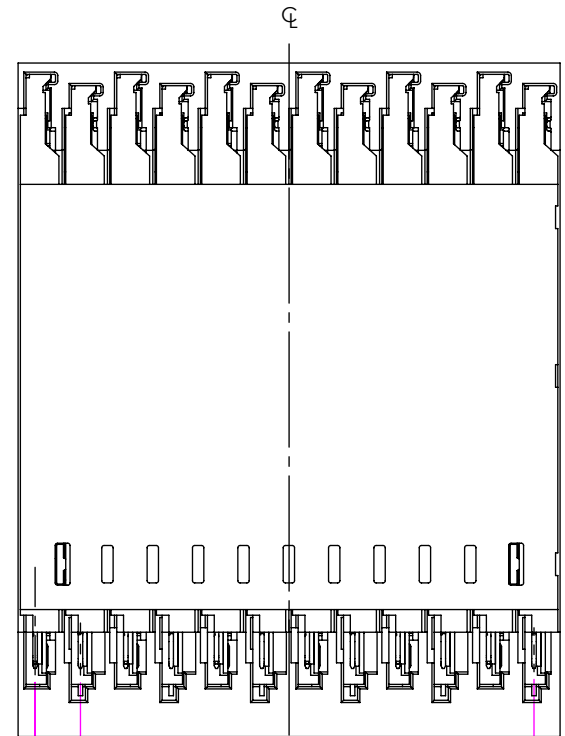

2.00 [.079] (9 PLCS)
 (TOL. NON-ACCUM)

"C"
 (TBL 1, SHT 1)
 "B"
 (TBL 1, SHT 1)

BACK VIEW

PROPRIETARY NOTE
 THIS DOCUMENT CONTAINS CONFIDENTIAL AND PROPRIETARY INFORMATION AND ALL DESIGN, MANUFACTURING, REPRODUCTION, USE, PATENT RIGHTS AND SALES RIGHTS ARE EXPRESSLY RESERVED BY SAMTEC, INC. THIS DOCUMENT SHALL NOT BE DISCLOSED, IN WHOLE OR PART, TO ANY UNAUTHORIZED PERSON OR ENTITY NOR REPRODUCED, TRANSFERRED OR INCORPORATED IN ANY OTHER PROJECT IN ANY MANNER WITHOUT THE EXPRESS WRITTEN CONSENT OF SAMTEC, INC.

DO NOT SCALE DRAWING
 SHEET SCALE: 3:1



520 PARK EAST BLVD, NEW ALBANY, IN 47150
 PHONE: 812-944-6733 FAX: 812-948-5047
 e-Mail info@SAMTEC.com code 55322

DESCRIPTION:
 EXAMAX™ RIGHT ANGLE HEADER ASSEMBLY

DWG. NO.
 EBTM-6-XX-2.0-X-RA-X-X-X

BY: B BLESSING 9/5/17 SHEET 3 OF 6

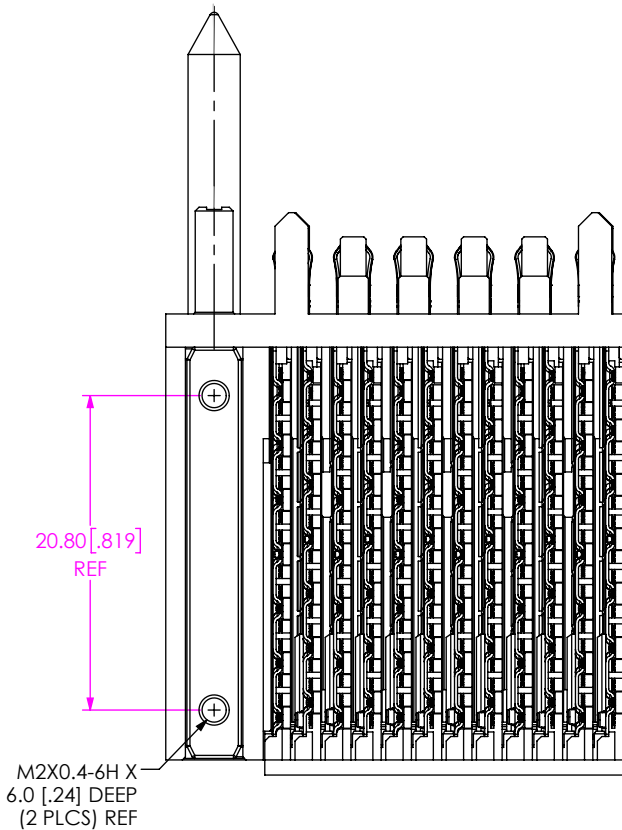
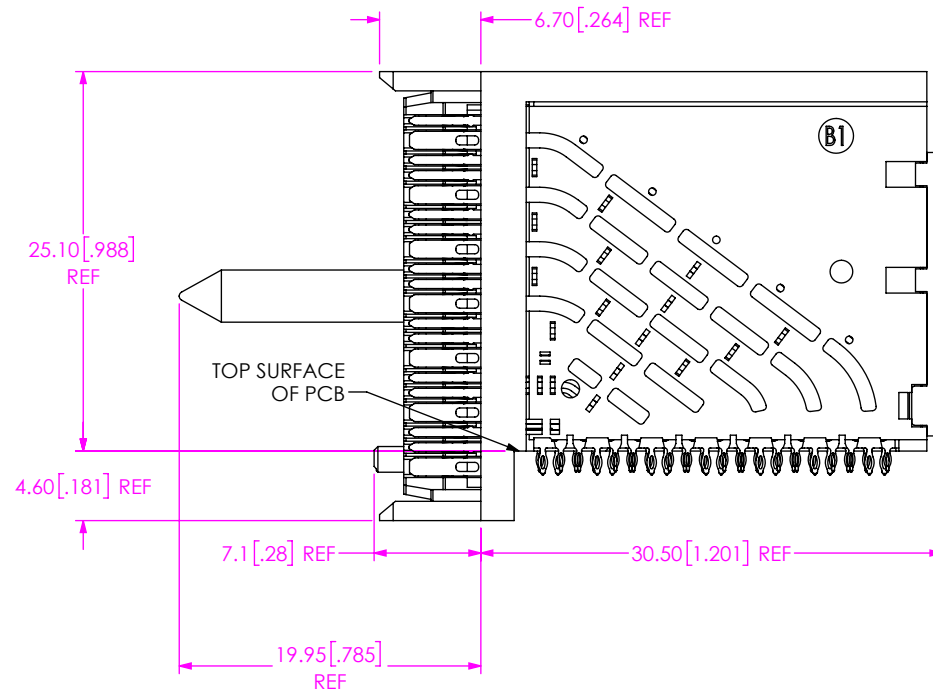
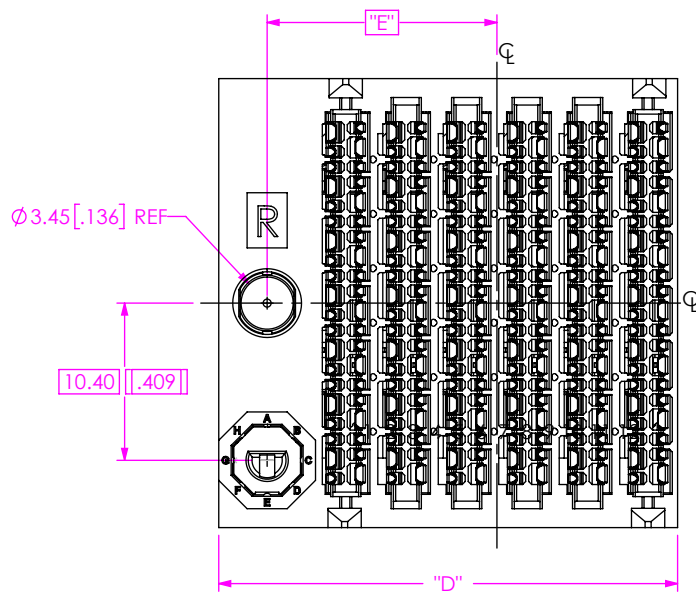

TABLE 2

COLUMNS	"D"	"E"
-06	18.35 [0.722]	9.20 [0.362]
-08	22.35 [0.880]	11.20 [0.441]
-10	26.35 [1.037]	13.20 [0.520]
-12	30.35 [1.195]	15.20 [0.598]

KEYING POSITION TABLE

		KEYING							
		-A	-B	-C	-D	-E	-F	-G	-H
-R / -L	H								
	G								

FIG 2
 RIGHT GUIDANCE
 EBTM-6-12-2.0-X-RA-X-R-A SHOWN
 (DIFFERENT AS SHOWN, OTHERWISE SAME AS FIG 1)

PROPRIETARY NOTE
 THIS DOCUMENT CONTAINS CONFIDENTIAL AND PROPRIETARY INFORMATION AND ALL DESIGN, MANUFACTURING, REPRODUCTION, USE, PATENT RIGHTS AND SALES RIGHTS ARE EXPRESSLY RESERVED BY SAMTEC, INC. THIS DOCUMENT SHALL NOT BE DISCLOSED, IN WHOLE OR PART, TO ANY UNAUTHORIZED PERSON OR ENTITY NOR REPRODUCED, TRANSFERRED OR INCORPORATED IN ANY OTHER PROJECT IN ANY MANNER WITHOUT THE EXPRESS WRITTEN CONSENT OF SAMTEC, INC.

DO NOT SCALE DRAWING
 SHEET SCALE: 1.5:1



520 PARK EAST BLVD, NEW ALBANY, IN 47150
 PHONE: 812-944-6733 FAX: 812-948-5047
 e-Mail info@SAMTEC.com code 55322

DESCRIPTION:
 EXAMAX™ RIGHT ANGLE HEADER ASSEMBLY

DWG. NO.
 EBTM-6-XX-2.0-X-RA-X-X-X

BY: B BLESSING 9/5/17 SHEET 4 OF 6

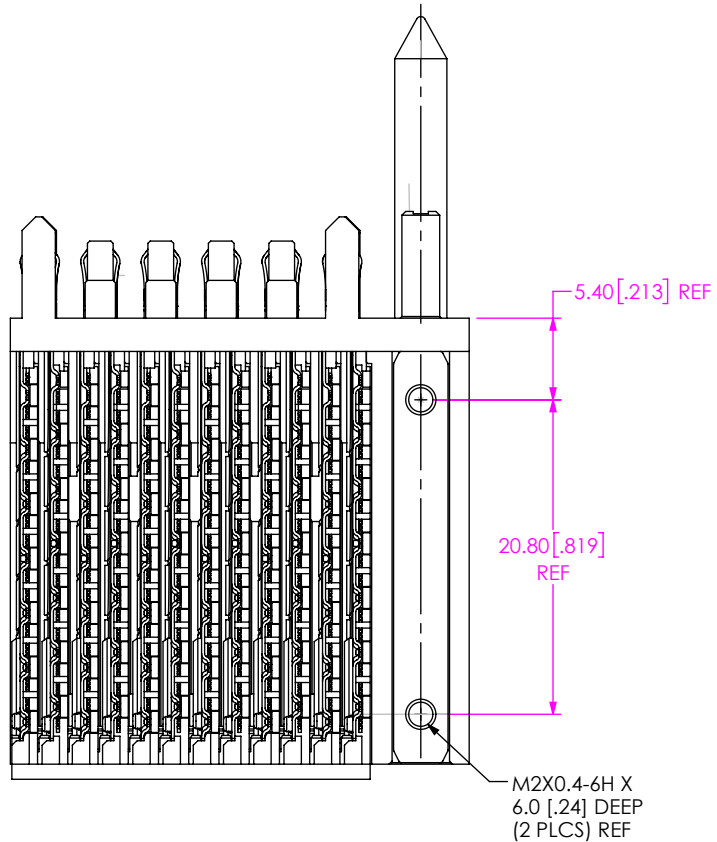
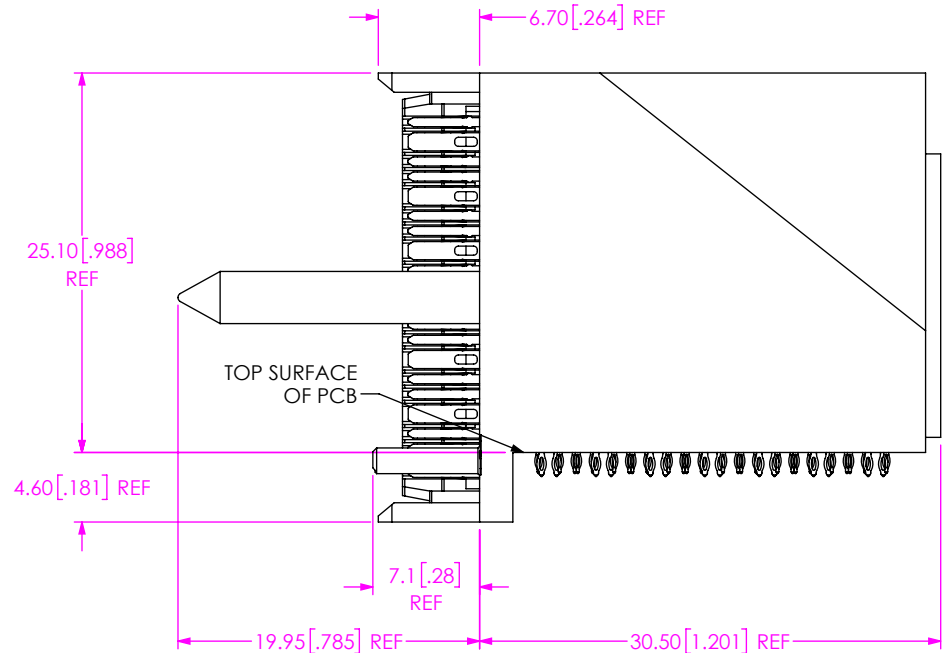
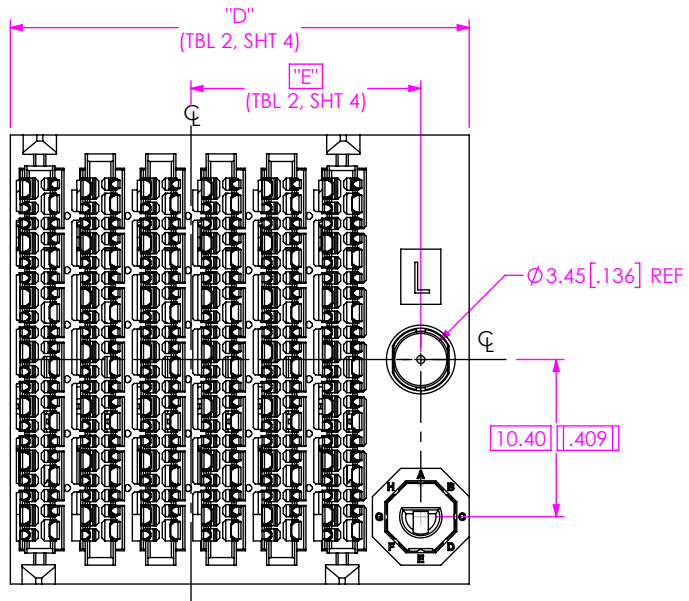

FIG 3
LEFT GUIDANCE
EBTM-6-12-2.0-X-RA-1-L-A SHOWN
(DIFFERENT AS SHOWN, OTHERWISE SAME AS FIG 2)

PROPRIETARY NOTE
 THIS DOCUMENT CONTAINS CONFIDENTIAL AND PROPRIETARY INFORMATION AND ALL DESIGN, MANUFACTURING, REPRODUCTION, USE, PATENT RIGHTS AND SALES RIGHTS ARE EXPRESSLY RESERVED BY SAMTEC, INC. THIS DOCUMENT SHALL NOT BE DISCLOSED, IN WHOLE OR PART, TO ANY UNAUTHORIZED PERSON OR ENTITY NOR REPRODUCED, TRANSFERRED OR INCORPORATED IN ANY OTHER PROJECT IN ANY MANNER WITHOUT THE EXPRESS WRITTEN CONSENT OF SAMTEC, INC.

DO NOT SCALE DRAWING

SHEET SCALE: 2:1

520 PARK EAST BLVD, NEW ALBANY, IN 47150
 PHONE: 812-944-6733 FAX: 812-948-5047
 e-Mail info@SAMTEC.com code 55322

DESCRIPTION:
EXAMAX™ RIGHT ANGLE HEADER ASSEMBLY

DWG. NO.
EBTM-6-XX-2.0-X-RA-X-X-X

BY: B BLESSING 9/5/17 SHEET 5 OF 6

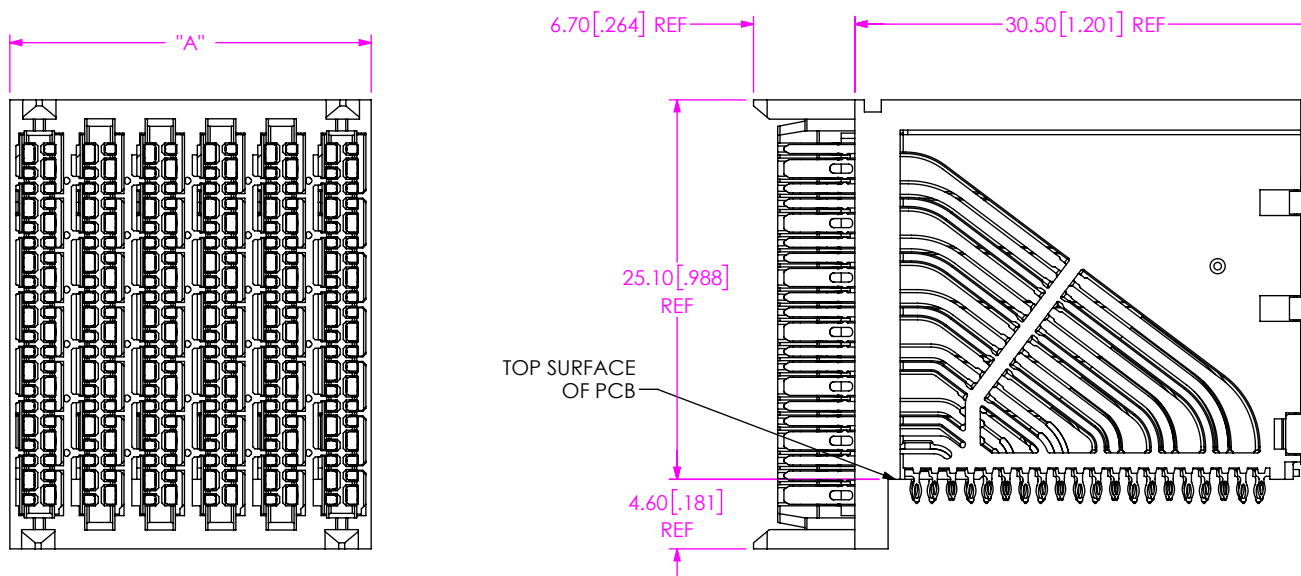
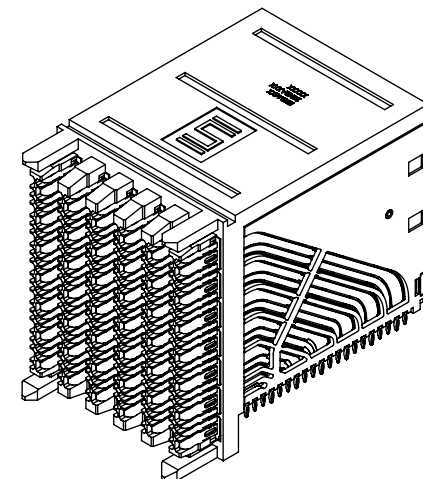

FIG 4
 OPEN PIN FIELD
 EBTM-6-12-2.0-X-RA-5 SHOWN
 (DIFFERENT AS SHOWN, OTHERWISE SAME AS FIG 1)

PROPRIETARY NOTE
 THIS DOCUMENT CONTAINS CONFIDENTIAL AND PROPRIETARY INFORMATION AND ALL DESIGN, MANUFACTURING, REPRODUCTION, USE, PATENT RIGHTS AND SALES RIGHTS ARE EXPRESSLY RESERVED BY SAMTEC, INC. THIS DOCUMENT SHALL NOT BE DISCLOSED, IN WHOLE OR PART, TO ANY UNAUTHORIZED PERSON OR ENTITY NOR REPRODUCED, TRANSFERRED OR INCORPORATED IN ANY OTHER PROJECT IN ANY MANNER WITHOUT THE EXPRESS WRITTEN CONSENT OF SAMTEC, INC.



520 PARK EAST BLVD., NEW ALBANY, IN 47150
 PHONE: 812-944-6733 FAX: 812-948-5047
 e-Mail info@SAMTEC.com code 55322

SHEET SCALE: 2:1

DESCRIPTION:
 EXAMAX™ RIGHT ANGLE HEADER ASSEMBLY

DWG. NO.
 EBTM-6-XX-2.0-X-RA-X-X-X

BY: B BLESSING 9/5/17 SHEET 6 OF 6