

DO NOT SCALE FROM THIS PRINT

No OF PAIRS
-16: 16 PAIRS (TOTAL)

CARD THICKNESS
-01: FOR .062" THICK BOARD

TAPE & REEL (SEE NOTE 4 & 5)
BLANK: TAPE & REEL
-FR: FULL REEL QTY TAPE & REEL

ROW SPECIFICATION
-RA: RIGHT ANGLE

PLATING SPECIFICATION
-L: 10µ" GOLD IN CONTACT AREA, MATTE TIN TAIL

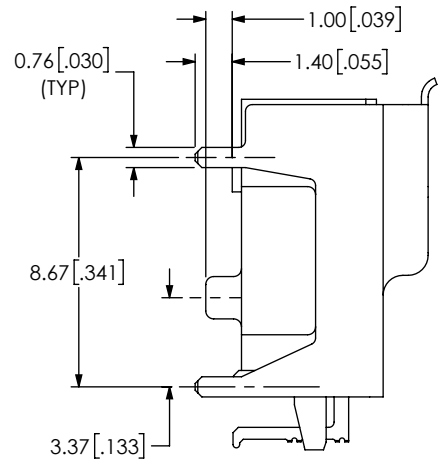
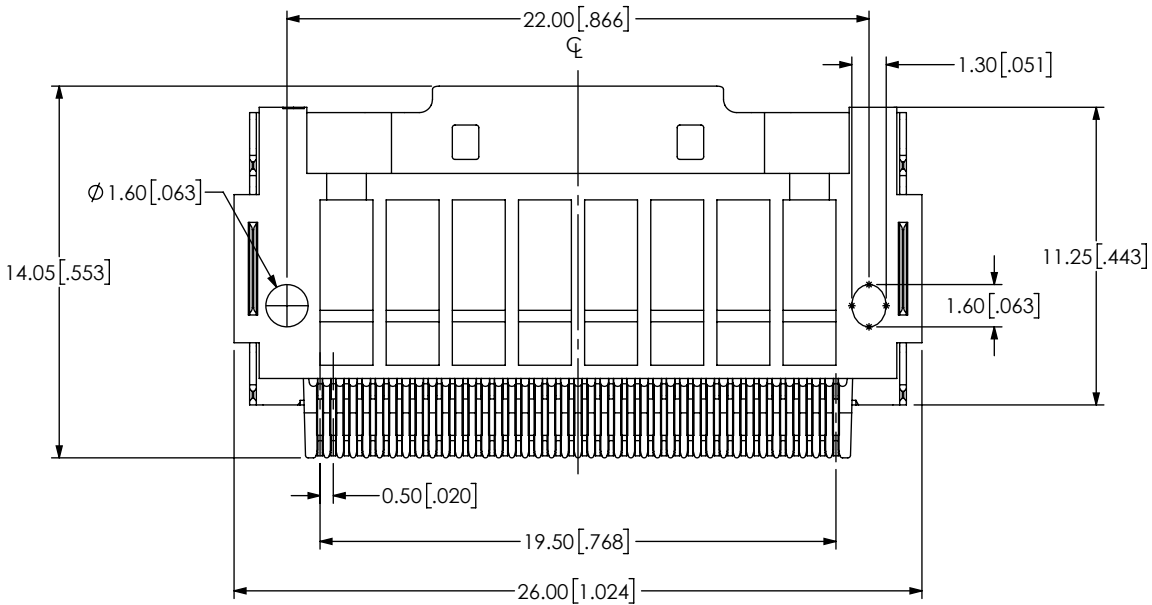
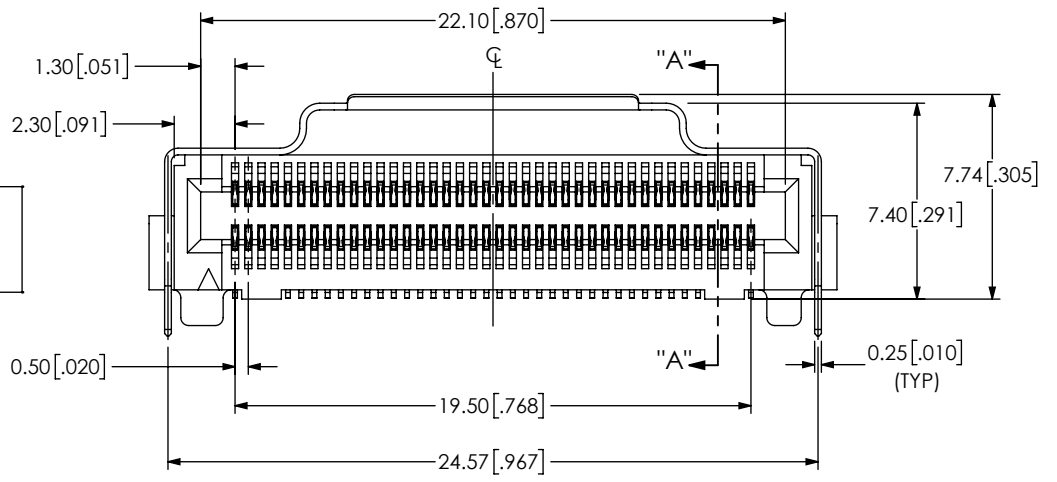
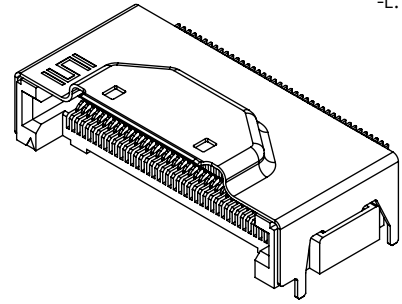
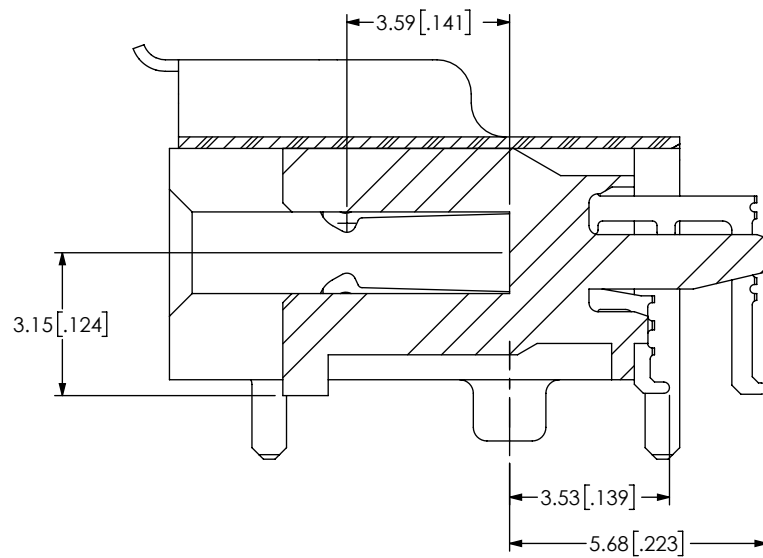

FIG 1
FCDP-16-01-X-RA SHOWN

- NOTES:
1. MATING CARD MUST HAVE LEAD-IN. SEE SAMTEC FOOTPRINT SPECIFICATIONS.
 2. NOTE DELETED.
 3. PARTS TO BE PACKAGED IN TAPE & REEL.
 4. ORDERS WILL BE PACKAGED ACCORDING TO THE SAMTEC PACKAGING EFFICIENCY STANDARDS (SPES) FOUND ON WWW.SAMTEC.COM
 5. ATTACH LABEL TO EACH REEL

<p>PROPRIETARY NOTE</p> <p>THIS DOCUMENT CONTAINS CONFIDENTIAL AND PROPRIETARY INFORMATION AND ALL DESIGN, MANUFACTURING, REPRODUCTION, USE, PATENT RIGHTS AND SALES RIGHTS ARE EXPRESSLY RESERVED BY SAMTEC, INC. THIS DOCUMENT SHALL NOT BE DISCLOSED, IN WHOLE OR PART, TO ANY UNAUTHORIZED PERSON OR ENTITY NOR REPRODUCED, TRANSFERRED OR INCORPORATED IN ANY OTHER PROJECT IN ANY MANNER WITHOUT THE EXPRESS WRITTEN CONSENT OF SAMTEC, INC.</p>		<p>samtec</p> <p>520 PARK EAST BLVD, NEW ALBANY, IN 47150 PHONE: 812-944-6733 FAX: 812-948-5047 e-Mail: info@SAMTEC.com code 55322</p>	
<p>DO NOT SCALE DRAWING SHEET SCALE: 3:5:1</p>		<p>DESCRIPTION: 0.5mm HIGH SPEED EDGE CARD ASSEMBLY</p>	
<p>MATERIAL: INSULATOR: LCP, UL 94 V0, COLOR: BLACK CONTACT: CU ALLOY SHIELD: CU ALLOY</p>		<p>DWG. NO. FCDP-XX-XX-X-RA-XX</p>	
<p>F:\DWG\MISC\MKTG\FCDP-XX-XX-X-RA-XX-MKT.SLDDRW</p>		<p>BY: JOE Z</p>	<p>07/27/2017</p>
		<p>SHEET 1 OF 2</p>	



SECTION "A"- "A"
SCALE 6 : 1

* PROPRIETARY NOTE *
THIS DOCUMENT CONTAINS CONFIDENTIAL AND PROPRIETARY INFORMATION AND ALL DESIGN, MANUFACTURING, REPRODUCTION, USE, PATENT RIGHTS AND SALES RIGHTS ARE EXPRESSLY RESERVED BY SAMTEC, INC. THIS DOCUMENT SHALL NOT BE DISCLOSED, IN WHOLE OR PART, TO ANY UNAUTHORIZED PERSON OR ENTITY NOR REPRODUCED, TRANSFERRED OR INCORPORATED IN ANY OTHER PROJECT IN ANY MANNER WITHOUT THE EXPRESS WRITTEN CONSENT OF SAMTEC, INC.



520 PARK EAST BLVD, NEW ALBANY, IN 47150
PHONE: 812-944-6733 FAX: 812-948-5047
e-Mail info@SAMTEC.com code 55322

DO NOT SCALE DRAWING

SHEET SCALE: 2:1

DESCRIPTION:
0.5mm HIGH SPEED EDGE CARD ASSEMBLY

DWG. NO. FCDP-XX-XX-X-RA-XX

BY: JOE Z 07/27/2017 SHEET 2 OF 2