

DO NOT
SCALE FROM
THIS PRINT

LEAD STYLE
-01

KIT OPTION
-1: USE WITH .062 THICK PCB
-2: USE WITH .093 THICK PCB
-N: NO HARDWARE

THREADING
-01: #0-80 UNF-3A

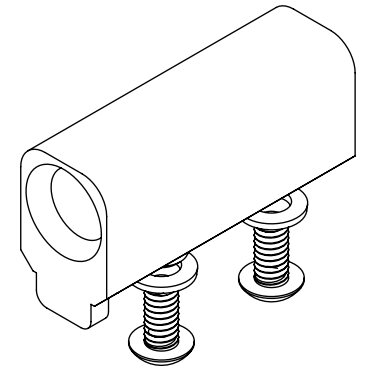
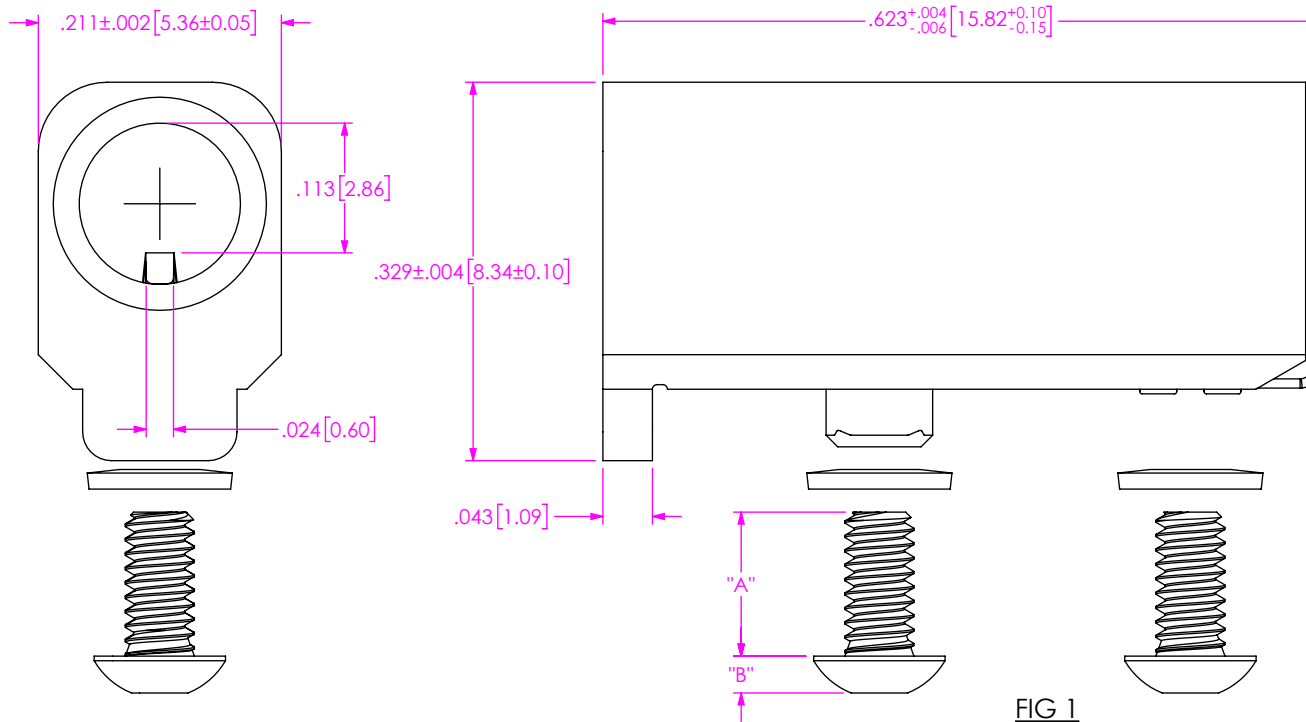
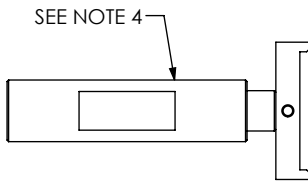

FIG 1
GPSKM-01-01 SHOWN



INSERTION TOOL
SCALE 1: 1

TABLE 1		
KIT OPTION	"A"	"B"
-1	.125	.032
-2	.188	.032

NOTES:

1. PARTS TO BE PACKAGED IN KITS ACCORDING TO THE SAMTEC PACKAGING MANUAL.
2. SCREWS AND LOCK WASHERS TO BE PACKAGED SEPARATELY.
3. TORQUE TO 2.5 - 3.5 IN*LB'S TO SECURE FASTENER IN A STATIC ENVIRONMENT.
4. USE INSERTION TOOL CAT-IN-VNX-GPRA TO PRESS THE ASSEMBLY ONTO THE BOARD (NOT PROVIDED).
5. PARTS TO BE USED WITH PCB THICKNESSES OF .062 TO .093.

PROPRIETARY NOTE
THIS DOCUMENT CONTAINS CONFIDENTIAL AND PROPRIETARY INFORMATION AND ALL DESIGN, MANUFACTURING, REPRODUCTION, USE, PATENT RIGHTS AND SALES RIGHTS ARE EXPRESSLY RESERVED BY SAMTEC, INC. THIS DOCUMENT SHALL NOT BE DISCLOSED, IN WHOLE OR PART, TO ANY UNAUTHORIZED PERSON OR ENTITY NOR REPRODUCED, TRANSFERRED OR INCORPORATED IN ANY OTHER PROJECT IN ANY MANNER WITHOUT THE EXPRESS WRITTEN CONSENT OF SAMTEC, INC.

MATERIAL: DO NOT SCALE DRAWING
SHEET SCALE: 6:1

SOCKET: ZINC
GROUND CLIP: COPPER ALLOY
SCREW, WASHER: STAINLESS STEEL



520 PARK EAST BLVD, NEW ALBANY, IN 47150
PHONE: 812-944-6733 FAX: 812-948-5047
e-Mail info@SAMTEC.com code 55322

DESCRIPTION: VNX+ GUIDANCE RECEPTACLE

DWG. NO. GPSKM-XX-XX-X

BY: DOSSEY D 7/8/2025 SHEET 1 OF 2

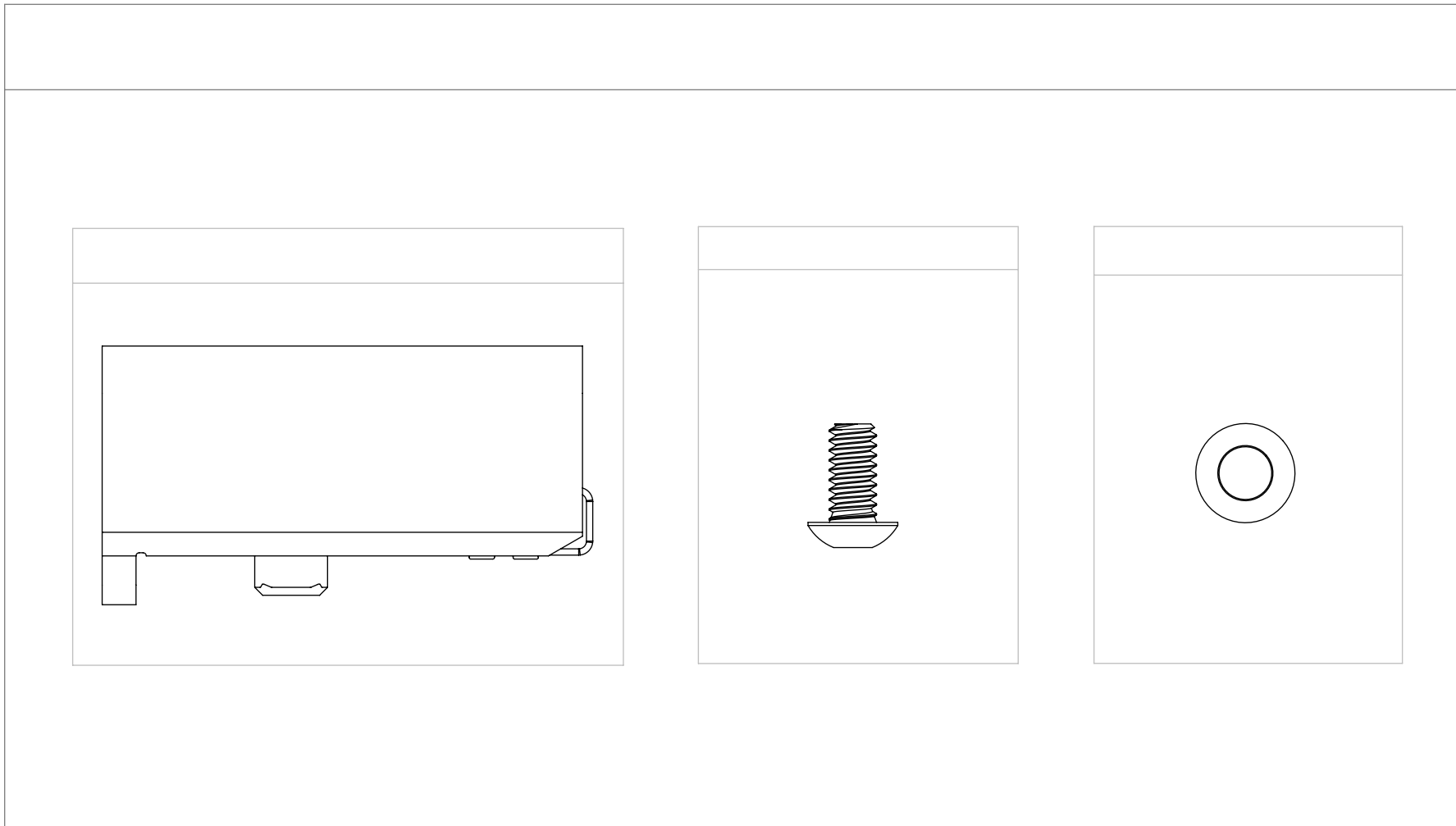

PACKAGING VIEW
NOT TO SCALE
 (ONLY ONE ITEM SHOWN PER BAG FOR CLARITY ONLY)

PROPRIETARY NOTE
 * THIS DOCUMENT CONTAINS CONFIDENTIAL AND PROPRIETARY INFORMATION AND ALL DESIGN, MANUFACTURING, REPRODUCTION, USE, PATENT RIGHTS AND SALES RIGHTS ARE EXPRESSLY RESERVED BY SAMTEC, INC. THIS DOCUMENT SHALL NOT BE DISCLOSED, IN WHOLE OR PART, TO ANY UNAUTHORIZED PERSON OR ENTITY NOR REPRODUCED, TRANSFERRED OR INCORPORATED IN ANY OTHER PROJECT IN ANY MANNER WITHOUT THE EXPRESS WRITTEN CONSENT OF SAMTEC, INC. *



520 PARK EAST BLVD, NEW ALBANY, IN 47150
 PHONE: 812-944-6733 FAX: 812-948-5047
 e-Mail info@SAMTEC.com code 55322

SHEET SCALE: 5:1

DESCRIPTION:
VNX+ GUIDANCE RECEPTACLE

DWG. NO.
GPSKM-XX-XX-X

BY: DOSSEY D 7/8/2025 SHEET 2 OF 2