

**DESIGNED & DIMENSIONED  
IN MILLIMETERS[INCHES]**

DO NOT  
SCALE FROM  
THIS PRINT

**HDBNC-P-C-XX-ST-CA8X-X**

GENDER  
-P: PLUG

TYPE  
-C: CABLE

PACKAGING  
-BLANK: INDIVIDUALLY BAGGED  
-B: BULK PACKAGED (QTY=100 MAX)

CRIMP OPTION  
(LEAVE BLANK FOR SOLDERED CENTER CONTACT)  
-C: CRIMPABLE CENTER CONTACT  
(USE HDBNC-P-C-X-ST-CA8-PIN-C)

TERMINATION  
-CA8: CCA-1855A  
CCA-4855R

ORIENTATION  
-ST: STRAIGHT

PLATING SPECIFICATION  
-HF: 30μ" GOLD CENTER CONTACT,  
3μ" GOLD OUTER CONTACT  
100μ" NICKEL ON OTHER COMPONENTS  
-HN: 30μ" GOLD CENTER CONTACT,  
100μ" NICKEL OUTER CONTACT  
-GF: 10μ" GOLD CENTER CONTACT,  
3μ" GOLD OUTER CONTACT  
100μ" NICKEL ON OTHER COMPONENTS  
-GN: 10μ" GOLD CENTER CONTACT,  
100μ" NICKEL OUTER CONTACT  
(SEE TABLE 1)

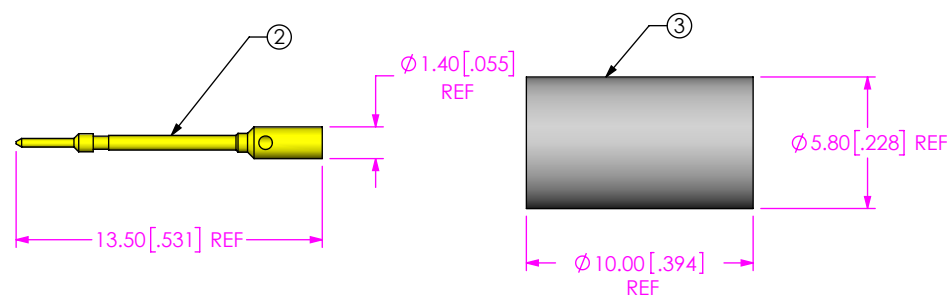
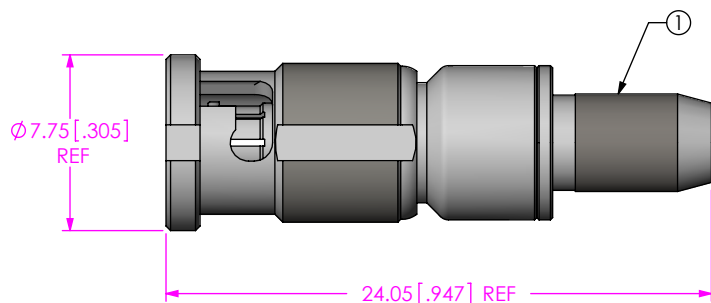

**TABLE 1**

ITEM	COMPONENT	-HF	-HN	-GF	-GN
1	SUB ASSEMBLY	SUB-HDBNC-P-C-FN-ST-CA8	SUB-HDBNC-P-C-NN-ST-CA8	SUB-HDBNC-P-C-FN-ST-CA8	SUB-HDBNC-P-C-NN-ST-CA8
2	PIN (SEE TABLE 2)	HDBNC-P-C-H-ST-CA8-PIN-X	HDBNC-P-C-H-ST-CA8-PIN-X	HDBNC-P-C-G-ST-CA8-PIN-X	HDBNC-P-C-G-ST-CA8-PIN-X
3	FERRULE	DINA-FER-001-N			

**TABLE 2**

OPTION	PIN
-CA8	HDBNC-P-C-X-ST-CA8-PIN
-CA8C	HDBNC-P-C-X-ST-CA8-PIN-C

NOTES:

- NOTE DELETED.
- PRODUCT TO BE PACKAGED PER PRECISION RF SECTION OF PACKAGING MANUAL.
- THE TEST RESULT OF THE CABLE PULL-OUT FORCE EXCEEDS 40 POUNDS.

UNLESS OTHERWISE SPECIFIED,  
DIMENSIONS ARE IN MILLIMETERS.

TOLERANCES ARE:  
DECIMALS ANGLES  
X.X: ±0.3 [.01] 5°  
X.XX: ±0.13 [.005]  
X.XXX: ±0.051 [.0020]

**PROPRIETARY NOTE**

THIS DOCUMENT CONTAINS CONFIDENTIAL AND PROPRIETARY INFORMATION AND ALL DESIGN, MANUFACTURING, REPRODUCTION, USE, PATENT RIGHTS AND SALES RIGHTS ARE EXPRESSLY RESERVED BY SAMTEC, INC. THIS DOCUMENT SHALL NOT BE DISCLOSED, IN WHOLE OR PART, TO ANY UNAUTHORIZED PERSON OR ENTITY NOR REPRODUCED, TRANSFERRED OR INCORPORATED IN ANY OTHER PROJECT IN ANY MANNER WITHOUT THE EXPRESS WRITTEN CONSENT OF SAMTEC, INC.

MATERIAL: DO NOT SCALE DRAWING SHEET SCALE: 3:1  
COUPLING NUT, SHELL, BODY, PIN, FERRULE : BRASS  
GASKET: SILICONE  
C-RING, FLAT WASHER: BRASS  
SPRING: STAINLESS STEEL  
DIELECTRIC: PTFE



520 PARK EAST BLVD, NEW ALBANY, IN 47150  
PHONE: 812-944-6733 FAX: 812-948-5047  
e-Mail info@SAMTEC.com code 55322

DESCRIPTION:  
75 OHM, HIGH DENSITY BNC STRAIGHT PLUG, RG59  
DWG. NO.  
**HDBNC-P-C-XX-ST-CA8X-X**  
BY: ALVIN W 02/16/2011 SHEET 1 OF 3



IN-PROCESS 1  
STRIP CABLE & TIN INNER CONDUCTOR

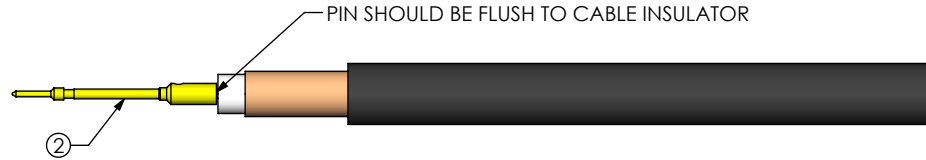

IN-PROCESS 2  
INDUCTION SOLDER SIGNAL CONTACT  
OR CRIMP (CA8C OPTION) USING .042" SQ. DIE

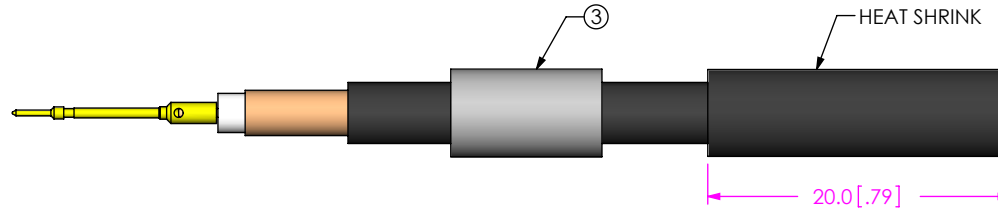

IN-PROCESS 3  
ADD FERRULE & HEAT SHRINK TUBING

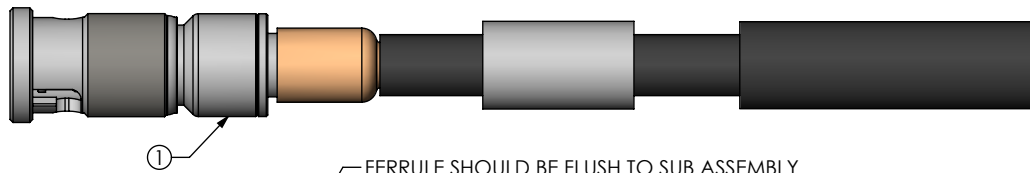

IN-PROCESS 4  
ADD SUB ASSEMBLY

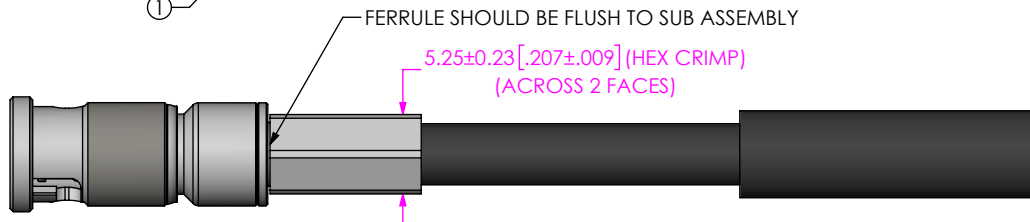

IN-PROCESS 5  
CRIMP FERRULE  
(USE RF CRIMP HAND TOOL #CAT-RF-FER-001  
AND .207" DIE SIZE)

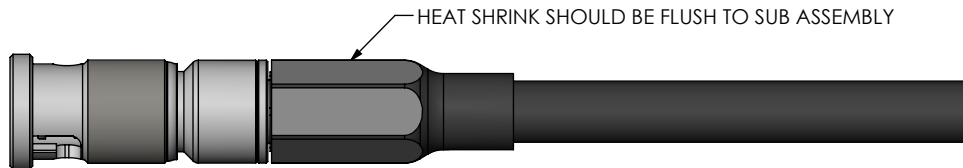

IN-PROCESS 6  
ACTIVATE HEAT SHRINK TUBING

**PROPRIETARY NOTE**  
THIS DOCUMENT CONTAINS CONFIDENTIAL AND PROPRIETARY INFORMATION AND ALL DESIGN, MANUFACTURING, REPRODUCTION, USE, PATENT RIGHTS AND SALES RIGHTS ARE EXPRESSLY RESERVED BY SAMTEC, INC. THIS DOCUMENT SHALL NOT BE DISCLOSED, IN WHOLE OR PART, TO ANY UNAUTHORIZED PERSON OR ENTITY NOR REPRODUCED, TRANSFERRED OR INCORPORATED IN ANY OTHER PROJECT IN ANY MANNER WITHOUT THE EXPRESS WRITTEN CONSENT OF SAMTEC, INC.

DO NOT SCALE DRAWING

SHEET SCALE: 2:1



520 PARK EAST BLVD, NEW ALBANY, IN 47150  
PHONE: 812-944-6733 FAX: 812-948-5047  
e-Mail info@SAMTEC.com code 55322

DESCRIPTION:  
75 OHM, HIGH DENSITY BNC STRAIGHT PLUG, RG59

DWG. NO.  
**HDBNC-P-C-XX-ST-CA8X-X**

BY:ALVIN W 02/16/2011 SHEET 2 OF 3

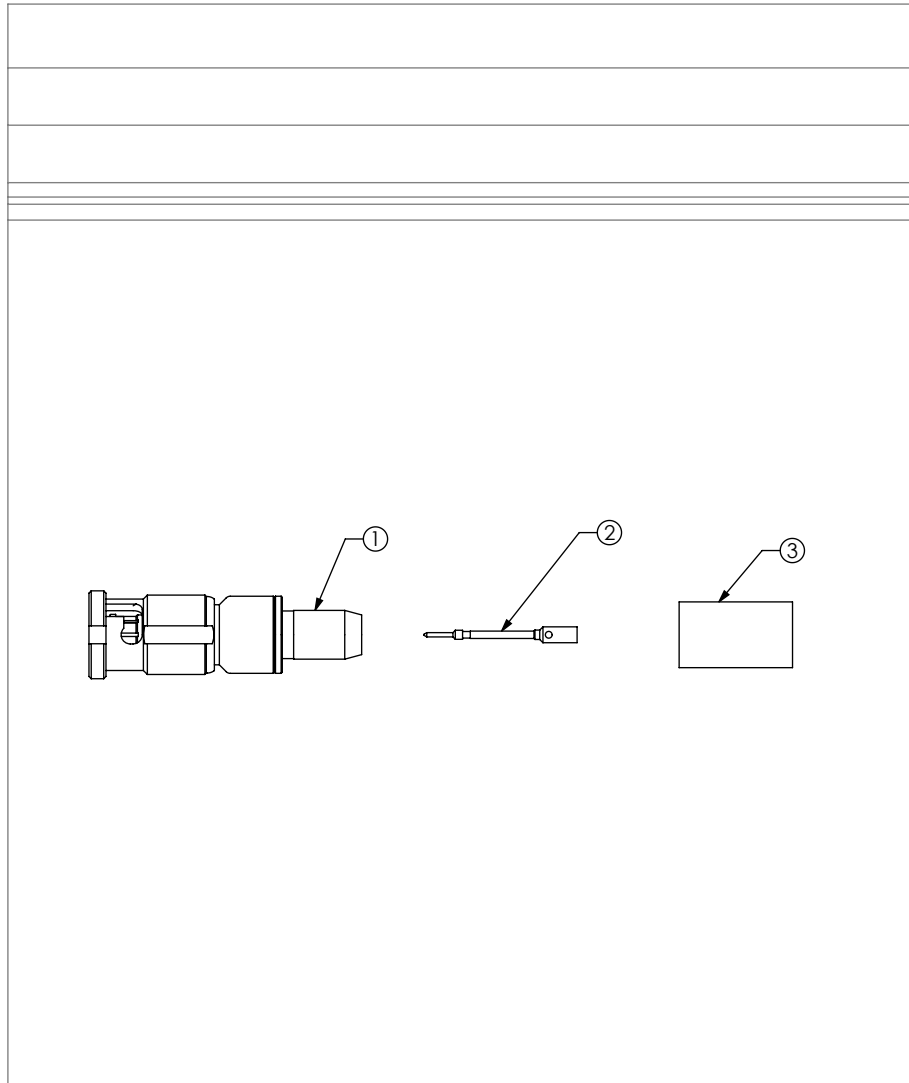

HDBNC-P-C-XX-ST-CA8X SHOWN

<p><b>PROPRIETARY NOTE</b></p> <p>THIS DOCUMENT CONTAINS CONFIDENTIAL AND PROPRIETARY INFORMATION AND ALL DESIGN, MANUFACTURING, REPRODUCTION, USE, PATENT RIGHTS AND SALES RIGHTS ARE EXPRESSLY RESERVED BY SAMTEC, INC. THIS DOCUMENT SHALL NOT BE DISCLOSED, IN WHOLE OR PART, TO ANY UNAUTHORIZED PERSON OR ENTITY NOR REPRODUCED, TRANSFERRED OR INCORPORATED IN ANY OTHER PROJECT IN ANY MANNER WITHOUT THE EXPRESS WRITTEN CONSENT OF SAMTEC, INC.</p>	 <p>520 PARK EAST BLVD, NEW ALBANY, IN 47150          PHONE: 812-944-6733 FAX: 812-948-5047          e-Mail info@SAMTEC.com code 55322</p>
<p>DO NOT SCALE DRAWING SHEET SCALE: 1:1          INSULATOR:          CONTACT OR TERMINAL:          SHIELD: PHOS BRONZE          PLATING:          CONTACT AREA: .000010 REF GOLD          REMAINDER: .000200 REF TIN</p>	<p>DESCRIPTION:          75 OHM, HIGH DENSITY BNC STRAIGHT PLUG, RG59</p> <p>DWG. NO.  <b>HDBNC-P-C-XX-ST-CA8X-X</b></p> <p>BY: ALVIN W 02/16/2011 SHEET 3 OF 3</p>