



DO NOT
SCALE FROM
THIS PRINT

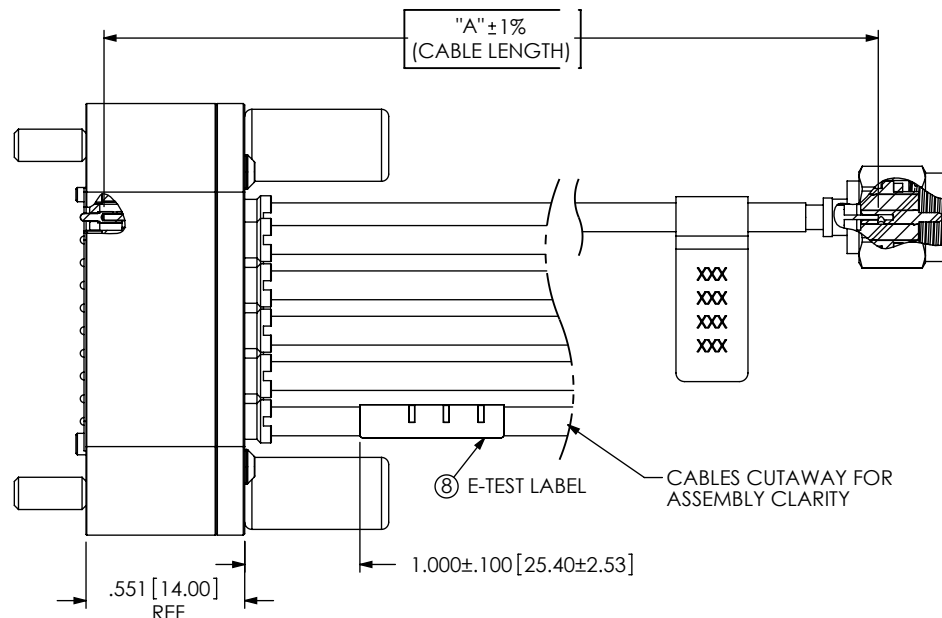
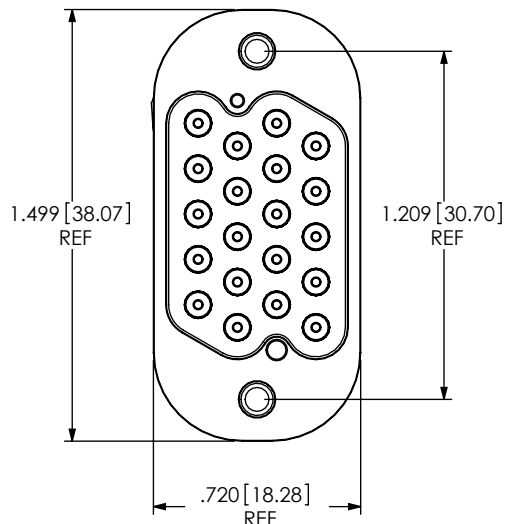

TABLE 1

PART #	SUB PART #	"A"	PHASE MATCH SPEC (PAIRS)
HDR-155805-01-BEYE	SUB-HDR-144733-11	24.00 [609.6]	2 PS
HDR-155805-06-BEYE	SUB-HDR-144733-23	12.00 [304.8]	4 PS
HDR-155805-07-BEYE	SUB-HDR-144733-20	9.45 [240.0]	4 PS
HDR-155805-08-BEYE	SUB-HDR-144733-21	19.69 [500.1]	4 PS
HDR-155805-09-BEYE	SUB-HDR-144733-05	36.00 [914.4]	4 PS
HDR-155805-10-BEYE	SUB-HDR-144733-26	6.00 [152.4]	4 PS
HDR-155805-11-BEYE	SUB-HDR-173594-05	24.00 [609.6]	4 PS
HDR-155805-17-BEYE	SUB-HDR-173594-22	12.00 [304.8]	2 PS

HDR-155805-XX-BEYE BOM

ITEM NO.	PART NUMBER	DESCRIPTION	QUANTITY	MATERIAL
1	SEE TABLE 1	SUB ASSEMBLY	20	SUB ASSEMBLY
2	CCS-159771-01-MD	CONNECTOR BODY	1	PLASTIC - VECTRA
3	CCS-159772-01-MD	COVER	1	ZINC
4	CCS-148582-01-MD	ELASTOMER	1	LAIRD ECE#89
5	STS-01	FASTENER	4	LOW CARBON STEEL
6	CCS-141062-01-MP	THUMBSCREW	2	BRASS
7	HDRL-16	LABEL	20	VINYL W/ ADHESIVE
8	LABEL-ET	E-TEST LABEL	1	VINYL W/ ADHESIVE
9	BG-09-12	ESD BAG	1	METALIZED PLY ETHYLENE
10	BG-02-03-Z	ESD BAG	1	METALIZED PLY ETHYLENE

NOTES:

1. NOT AVAILABLE AS STANDARD
2. © REPRESENTS A CRITICAL DIMENSION.
3. PARTS TO BE PROCESSED PER SAMTEC BOUNDARY DOCUMENT GUIDELINES.
4. ALL ASSEMBLIES TO BE 100% ELECTRICALLY TESTED.
5. SEE SHEET 2 FOR PHASE MATCHING REQUIREMENTS.
6. TIGHTEN ITEM 5 FASTENERS TO 2.0-2.3 IN-LBS (4 PLCS)
7. PRINT CABLE POSITION (4 LINES PER LABEL) AND APPLY TO CABLES (TAG STYLE) AS SHOWN. LABELS CAN BE ORIENTED IN ANY DIRECTION.

TOLERANCES DO NOT APPLY TO REFERENCE DIMENSIONS. UNLESS OTHERWISE SPECIFIED, DIMENSIONS ARE IN INCHES. TOLERANCES ARE:
DECIMALS .XX: ± .01 [.3]
.XXX: ± .005 [.13]
.XXXX: ± .002 [.051]

PROPRIETARY NOTE
THIS DOCUMENT CONTAINS CONFIDENTIAL AND PROPRIETARY INFORMATION AND ALL DESIGN, MANUFACTURING, REPRODUCTION, USE, PATENT RIGHTS AND SALES RIGHTS ARE EXPRESSLY RESERVED BY SAMTEC, INC. THIS DOCUMENT SHALL NOT BE DISCLOSED, IN WHOLE OR PART, TO ANY UNAUTHORIZED PERSON OR ENTITY NOR REPRODUCED, TRANSFERRED OR INCORPORATED IN ANY OTHER PROJECT IN ANY MANNER WITHOUT THE EXPRESS WRITTEN CONSENT OF SAMTEC, INC.



520 PARK EAST BLVD, NEW ALBANY, IN 47150
PHONE: 812-944-6733 FAX: 812-948-5047
e-Mail: info@SAMTEC.com code 55322

DO NOT SCALE DRAWING SHEET SCALE: 1:1

DESCRIPTION: CUSTOM HDR CABLE ASSEMBLY

DWG. NO. HDR-155805-XX-BEYE

BY: NIELS E. 12/27/2010 SHEET 1 OF 5

PATENT NUMBER
7,544,093

REVISION L

CAUTION: EACH PAIR OF CABLES MUST BE PHASE MATCHED PER TABLE 1. IF RE-WORKED, THE ENTIRE PAIR MUST BE REPLACED.

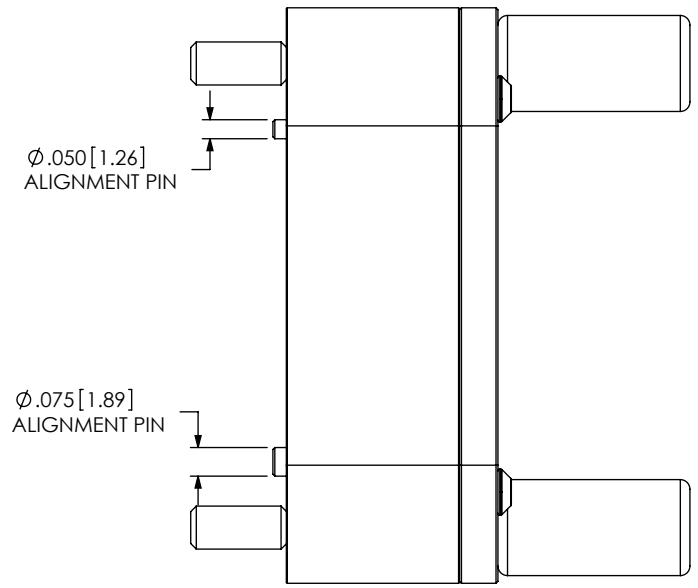

PHASED MATCH PAIRS		
LOCATION	DESCRIPTION	PAIR NO.
1	TX0-P	1
2	TX0-N	1
3	RX0-P	2
4	RX0-N	2
5	TX1-P	3
6	TX1-N	3
7	RX1-P	4
8	RX1-N	4
9	TX2-P	5
10	TX2-N	5
11	RX2-P	6
12	RX2-N	6
13	TX3-P	7
14	TX3-N	7
15	RX3-P	8
16	RX3-N	8
17	CLK0-P	9
18	CLK0-N	9
19	CLK1-P	10
20	CLK1-N	10

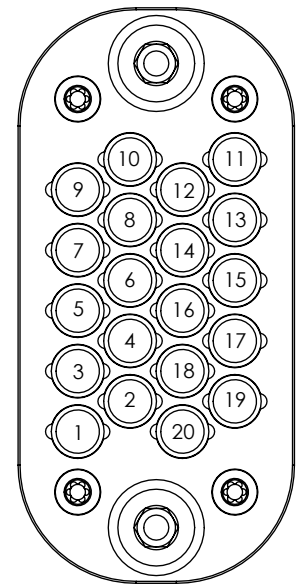

<p>PROPRIETARY NOTE</p> <p>THIS DOCUMENT CONTAINS CONFIDENTIAL AND PROPRIETARY INFORMATION AND ALL DESIGN, MANUFACTURING, REPRODUCTION, USE, PATENT RIGHTS AND SALES RIGHTS ARE EXPRESSLY RESERVED BY SAMTEC, INC. THIS DOCUMENT SHALL NOT BE DISCLOSED, IN WHOLE OR PART, TO ANY UNAUTHORIZED PERSON OR ENTITY NOR REPRODUCED, TRANSFERRED OR INCORPORATED IN ANY OTHER PROJECT IN ANY MANNER WITHOUT THE EXPRESS WRITTEN CONSENT OF SAMTEC, INC.</p>	 <p>520 PARK EAST BLVD, NEW ALBANY, IN 47150 PHONE: 812-944-6733 FAX: 812-948-5047 e-Mail: info@SAMTEC.com code 55322</p>	
	<p>DO NOT SCALE DRAWING</p>	<p>DESCRIPTION: CUSTOM HDR CABLE ASSEMBLY</p>
	<p>SHEET SCALE: 1:1</p>	<p>DWG. NO. HDR-155805-XX-BEYE</p>
<p>BY: NIELS E. 12/27/2010</p>		<p>SHEET 2 OF 5</p>

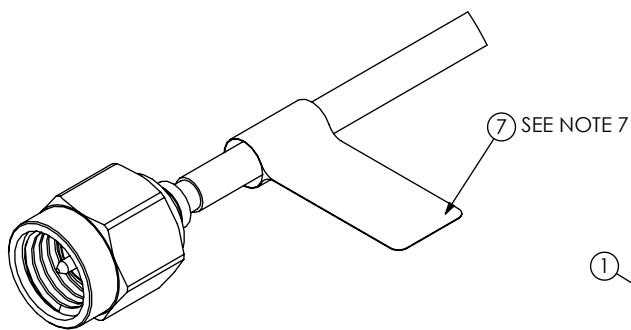
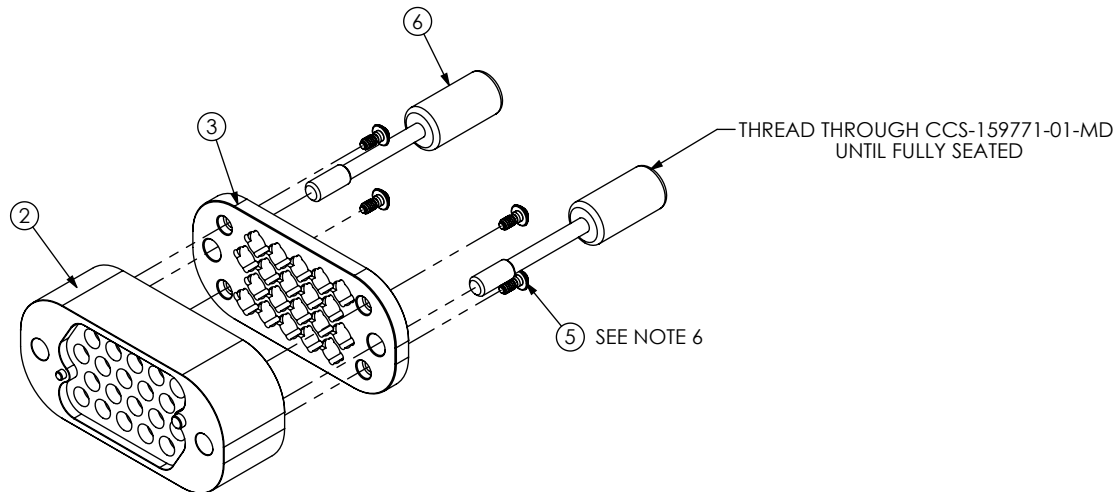

DETAIL 'A'
SCALE 2:1

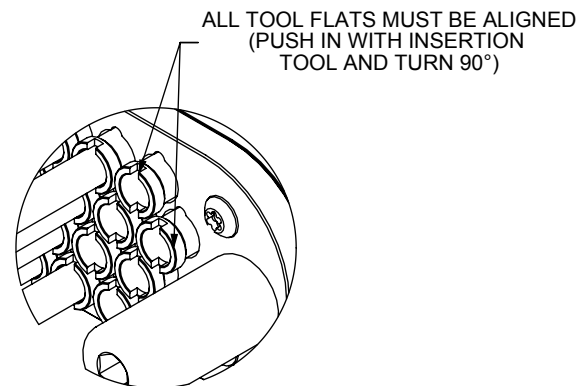
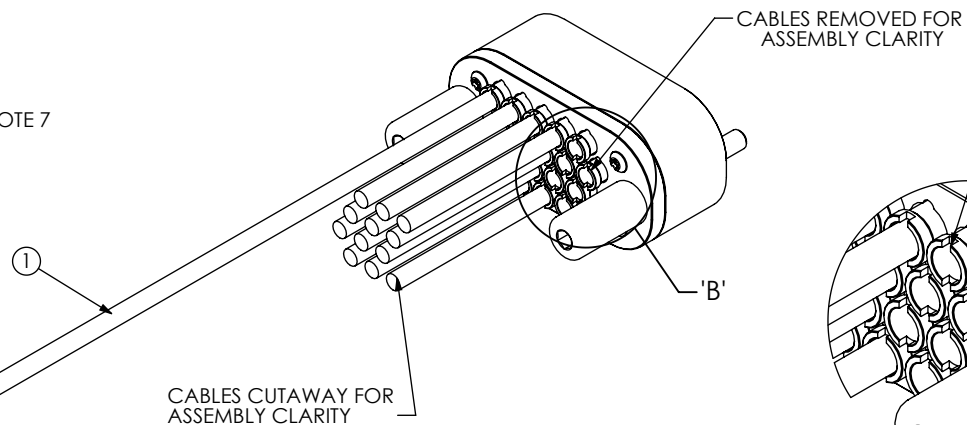
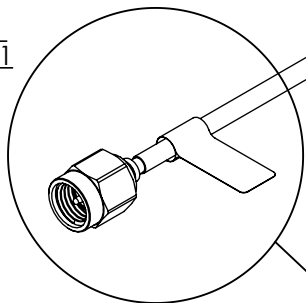

DETAIL 'B'
SCALE 2:1

PROPRIETARY NOTE
 * THIS DOCUMENT CONTAINS CONFIDENTIAL AND PROPRIETARY INFORMATION AND ALL DESIGN, MANUFACTURING, REPRODUCTION, USE, PATENT RIGHTS AND SALES RIGHTS ARE EXPRESSLY RESERVED BY SAMTEC, INC. THIS DOCUMENT SHALL NOT BE DISCLOSED, IN WHOLE OR PART, TO ANY UNAUTHORIZED PERSON OR ENTITY NOR REPRODUCED, TRANSFERRED OR INCORPORATED IN ANY OTHER PROJECT IN ANY MANNER WITHOUT THE EXPRESS WRITTEN CONSENT OF SAMTEC, INC. *



520 PARK EAST BLVD, NEW ALBANY, IN 47150
 PHONE: 812-944-6733 FAX: 812-948-5047
 e-Mail: info@SAMTEC.com code 55322

DO NOT SCALE DRAWING

DESCRIPTION:
CUSTOM HDR CABLE ASSEMBLY

DWG. NO.

HDR-155805-XX-BEYE

SHEET SCALE: 1:2

BY: NIELS E. 12/27/2010 SHEET 3 OF 5

PACKAGING VIEW

INCLUDE ITEM 4 IN BAG WITH FINISHED ASSEMBLY AS SHOWN

ENDS OF CABLE ASSEMBLY TO BE WRAPPED
IN ANTI-STATIC BUBBLE WRAP

PATENT NUMBER
7,544,093

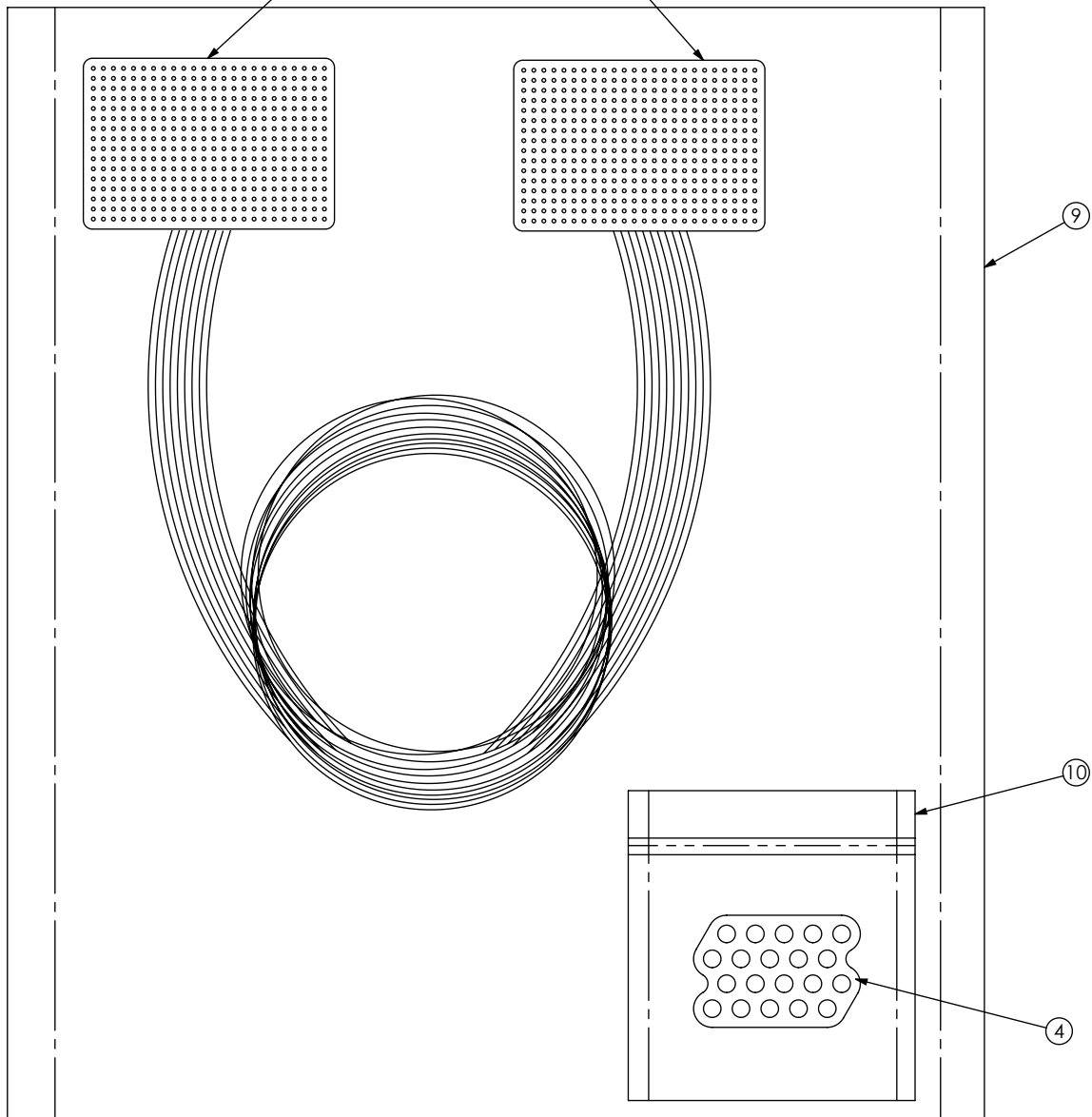

PROPRIETARY NOTE
 * THIS DOCUMENT CONTAINS CONFIDENTIAL AND PROPRIETARY INFORMATION AND ALL DESIGN, MANUFACTURING, REPRODUCTION, USE, PATENT RIGHTS AND SALES RIGHTS ARE EXPRESSLY RESERVED BY SAMTEC, INC. THIS DOCUMENT SHALL NOT BE DISCLOSED, IN WHOLE OR PART, TO ANY UNAUTHORIZED PERSON OR ENTITY NOR REPRODUCED, TRANSFERRED OR INCORPORATED IN ANY OTHER PROJECT IN ANY MANNER WITHOUT THE EXPRESS WRITTEN CONSENT OF SAMTEC, INC. *



520 PARK EAST BLVD, NEW ALBANY, IN 47150
 PHONE: 812-944-6733 FAX: 812-948-5047
 e-Mail info@SAMTEC.com code 55322

DO NOT SCALE DRAWING

DESCRIPTION:
CUSTOM HDR CABLE ASSEMBLY

DWG. NO.
HDR-155805-XX-BEYE

SHEET SCALE: 1:2

BY: NIELS E. 12/27/2010 SHEET 4 OF 5

APPLICATION VIEW

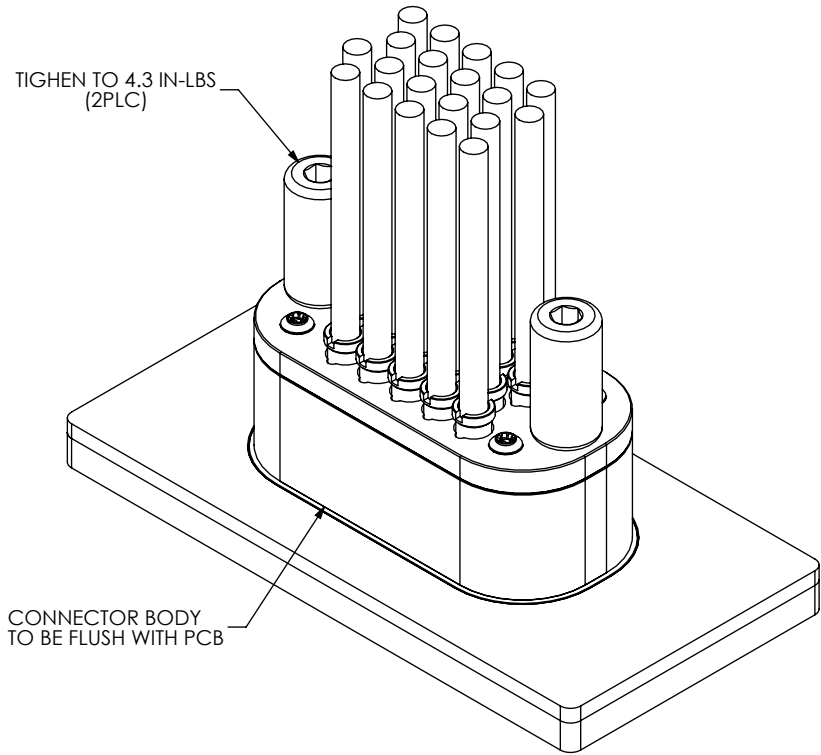
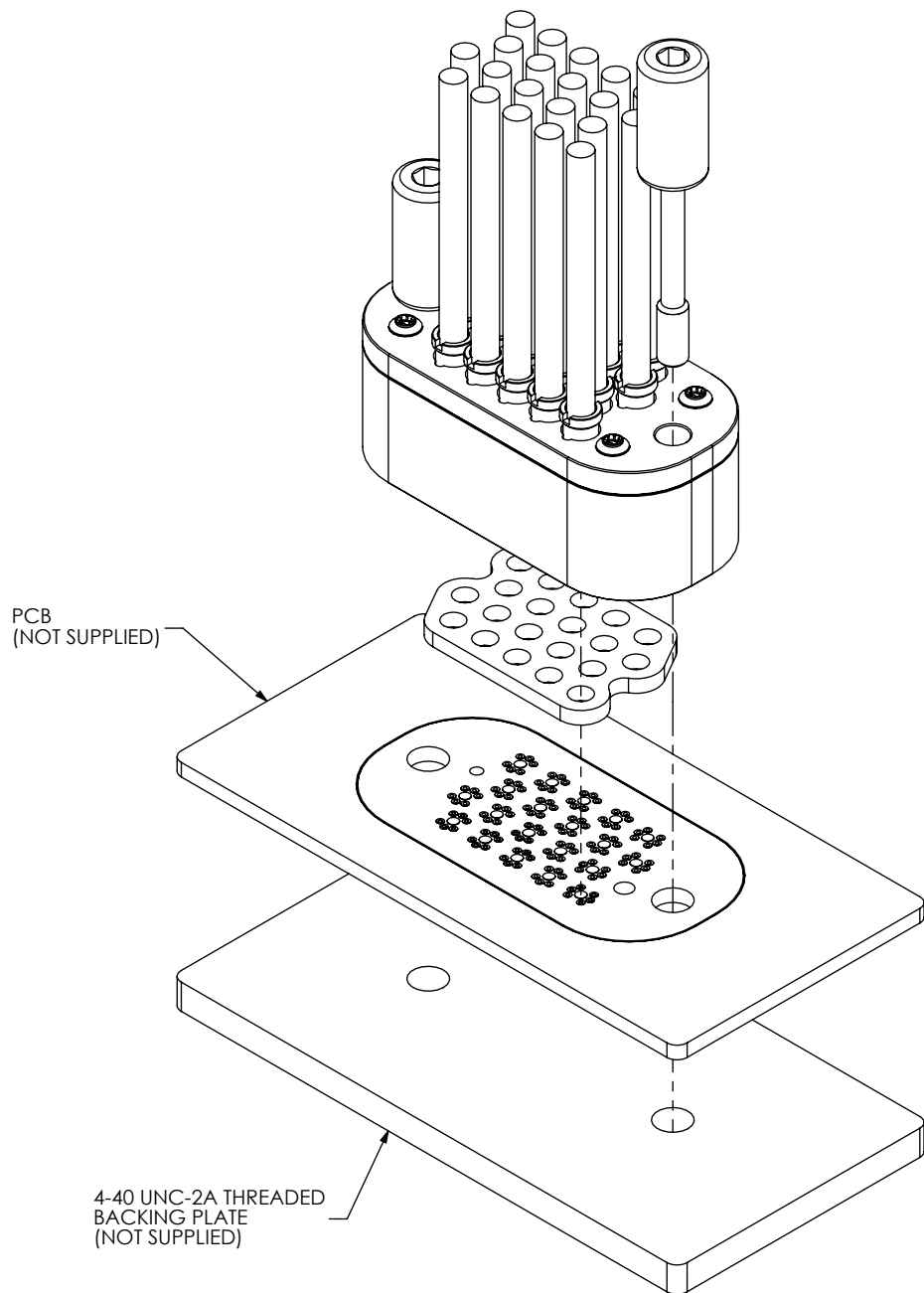

<p>DO NOT SCALE DRAWING</p> <p>SHEET SCALE: 1:2</p>	<p>PROPRIETARY NOTE</p> <p>THIS DOCUMENT CONTAINS CONFIDENTIAL AND PROPRIETARY INFORMATION AND ALL DESIGN, MANUFACTURING, REPRODUCTION, USE, PATENT RIGHTS AND SALES RIGHTS ARE EXPRESSLY RESERVED BY SAMTEC, INC. THIS DOCUMENT SHALL NOT BE DISCLOSED, IN WHOLE OR PART, TO ANY UNAUTHORIZED PERSON OR ENTITY NOR REPRODUCED, TRANSFERRED OR INCORPORATED IN ANY OTHER PROJECT IN ANY MANNER WITHOUT THE EXPRESS WRITTEN CONSENT OF SAMTEC, INC.</p>	<p>520 PARK EAST BLVD, NEW ALBANY, IN 47150 PHONE: 812-944-6733 FAX: 812-948-5047 e-Mail: info@SAMTEC.com code 55322</p>
	<p>DESCRIPTION:</p> <p>CUSTOM HDR CABLE ASSEMBLY</p>	<p>DWG. NO.</p> <p>HDR-155805-XX-BEYE</p>
	<p>BY: NIELS E.</p>	<p>12/27/2010 SHEET 5 OF 5</p>