

TERMINAL SPECIFICATION	TERMINAL	"C" REF
-H	T-1R6-X	.300 [7.62]
-R	T-2R6-X	.332 [8.43]
-T	T-3R6-X	.235 [5.97]

DIMENSIONS ARE IN INCHES		UNLESS OTHERWISE NOTED		TOLERANCES ARE:		TITLE:	DWG NO:
ONE PLACE DECIMALS: ±	THREE PLACE DECIMALS: ±	ANGLES		±		HLT ASSEMBLY	HLT-XXXX-X-X
TWO PLACE DECIMALS: ±	FOUR PLACE DECIMALS: ±						SHEET 1 OF 1

PACKAGING TABLE	
ROW SPECIFICATION	PACKAGE IN
-01	PT-1-24-01-23 / TP-12 (2)
-02	PT-1-24-01-14 / TP-03 (2)
-03 & -04	BULK
-05 THRU -20	BEAD BOARD

ROW SPECIFICATION
(SEE FIG. 1)
EXPRESSED IN NO. OF ROWS
1 THRU 20

BODY LENGTH SPECIFICATION
(SEE FIG. 1)
EXPRESSED IN NO. OF POS. PER ROW
1 THRU 20

TERMINAL SPECIFICATION
(SEE TABLE 1)

PLATING SPECIFICATION
-G: GOLD, SPECIFY -G IN TERMINAL SUFFIX -X
-T: TIN, SPECIFY -T IN TERMINAL SUFFIX -X

HLT-XXXX-X-X

- NOTES:
- 1.) FILL ALL POSITIONS.
 - 2.) PINS TO ENTER BODY FROM C'BORE SIDE.
 - 3.) BARB ON SOCKET MUST BE VISABLE BELOW BODY.

ASSEMBLY INSTRUCTIONS

DO NOT SCALE FROM THIS PRINT

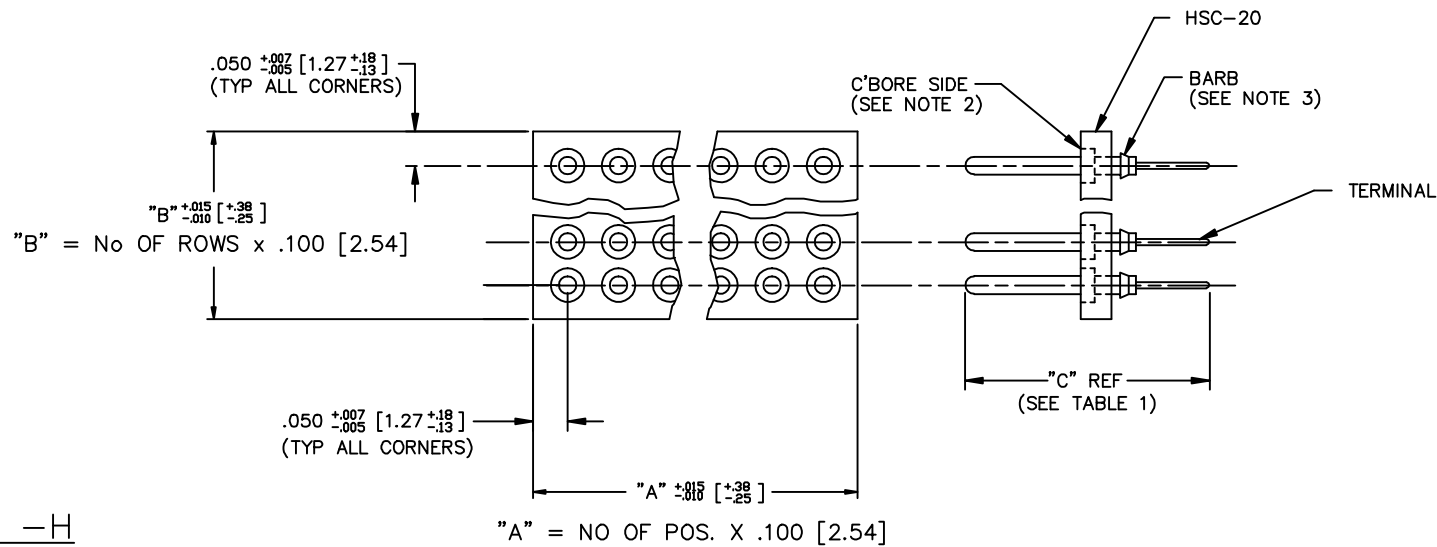

STYLE -H

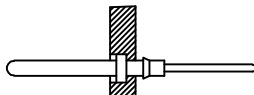

FIGURE 1

TERMINALS TO BE RECESSED (COUNTER-SUNK) INTO BODY TO ALLOW BARB PROTRUSION AT BOTTOM

PROPRIETARY NOTE
THIS DOCUMENT CONTAINS INFORMATION CONFIDENTIAL AND PROPRIETARY TO SAMTEC INC. AND SHALL NOT BE REPRODUCED OR TRANSFERRED TO OTHER DOCUMENTS OR DISCLOSED TO OTHERS OR USED FOR ANY PURPOSE OTHER THAN THAT FOR WHICH IT WAS OBTAINED WITHOUT THE EXPRESSED WRITTEN CONSENT OF SAMTEC INC.

MATERIAL: PET POLYESTER COLOR: BLACK	<p>520 PARK EAST BLVD. NEW ALBANY, INDIANA 47150 PHONE (812) 944-6733 P.O. BOX 1147 CODE 55322</p>	MISC\MKMG HLT-MKT					
TERMINAL: PHOS BRONZE		<table border="1"> <tr> <td>MADE BY: JORDAN 5-29-85</td> <td>ENGINEER APPROVAL BET 6-4-85</td> <td>HLT-XXXX-X-X</td> </tr> <tr> <td>CHECKED BY: THRUSTON 6-4-85</td> <td></td> <td>SHEET 1 OF 1</td> </tr> </table>	MADE BY: JORDAN 5-29-85	ENGINEER APPROVAL BET 6-4-85	HLT-XXXX-X-X	CHECKED BY: THRUSTON 6-4-85	
MADE BY: JORDAN 5-29-85	ENGINEER APPROVAL BET 6-4-85	HLT-XXXX-X-X					
CHECKED BY: THRUSTON 6-4-85		SHEET 1 OF 1					