

DO NOT SCALE FROM THIS PRINT

**DESIGNED & DIMENSIONED IN MILLIMETERS [INCHES]**

**LPHS-XX-XX-X-RTX-XX**

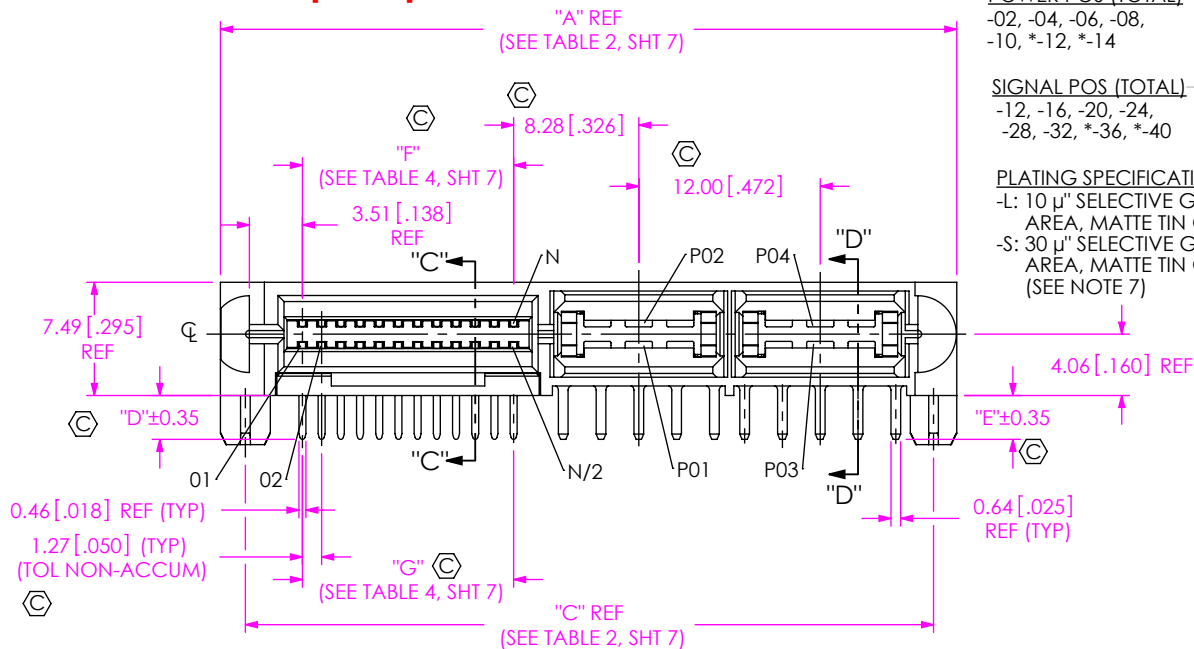

**POWER POS (TOTAL)**

-02, -04, -06, -08, -10, \*-12, \*-14

**SIGNAL POS (TOTAL)**

-12, -16, -20, -24, -28, -32, \*-36, \*-40

**PLATING SPECIFICATION**

-L: 10 μ" SELECTIVE GOLD IN CONTACT AREA, MATTE TIN ON TAIL  
 -S: 30 μ" SELECTIVE GOLD IN CONTACT AREA, MATTE TIN ON TAIL (SEE NOTE 7)

**OPTIONS**

-GP: GUIDE POSTS (LEAVE BLANK FOR NO -GP OPTION)  
 -BLANK: NO GP OPTION

**TAIL**

-RT1: RA-TH, 1.58[.062] BOARD  
 -RT2: RA-TH, 2.36[.093] BOARD

(\* = NOT TOOLED)

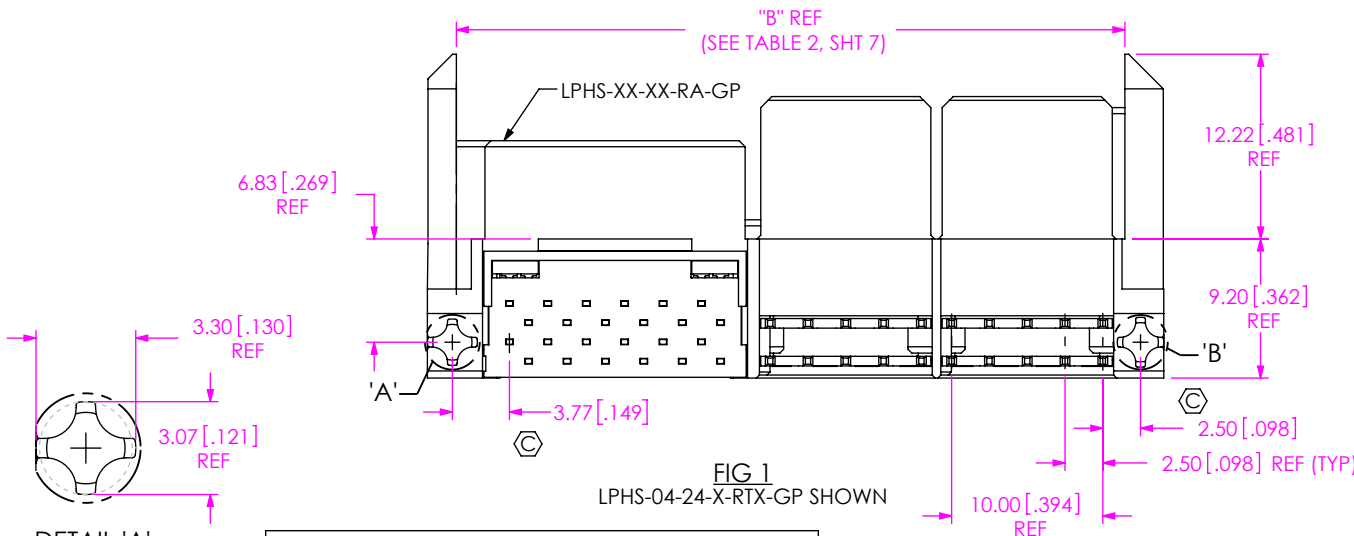
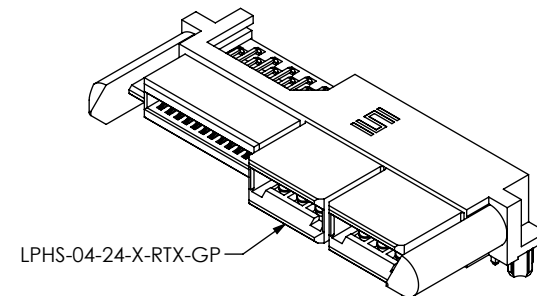

DETAIL 'A' SCALE 4:1

FIG 1 LPHS-04-24-X-RTX-GP SHOWN

TABLE 1				
TAIL	ROW 1 POWER	ROW 2 POWER	"D"	"E"
-RT1	C-377-02-01-X	C-377-01-01-X	2.90 [.114]	2.90 [.114]
-RT2	C-377-02-02-X	C-377-01-02-X	3.60 [.142]	3.60 [.142]

**NOTES:**

- ⊗ REPRESENTS A CRITICAL DIMENSION.
- MINIMUM PUSHOUT FORCE: SIGNAL: 0.5 LBS, POWER PIN: 3.0 LBS.
- MAXIMUM ALLOWABLE BOW: 0.15[.006] MM/MM AFTER ASSEMBLY.
- MAXIMUM BURR ON SHEARED TAILS: 0.15[.006].
- ALL P/N'S REQUIRE PRESSING TO PCB DUE TO ALIGNMENT PEGS, CONTACT SAMTEC FOR REQUIRED FIXTURES.
- ASSEMBLIES TO BE PACKAGED IN TRAYS.
- SELECTIVE PLATING LUBRICATED WITH ACCL-53T WHICH CAN BE DETECTED USING A UVA ULTRAVIOLET LIGHT SOURCE.

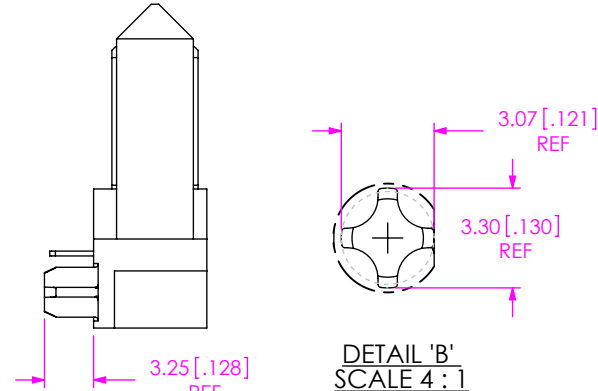

DETAIL 'B' SCALE 4:1

UNLESS OTHERWISE SPECIFIED, DIMENSIONS ARE IN MILLIMETERS.

TOLERANCES ARE:

DECIMALS ANGLES  
 X.X: ±0.3 [.01] 2°  
 X.XX: ±0.13 [.005]  
 X.XXX: ±0.051 [.0020]

**PROPRIETARY NOTE**

THIS DOCUMENT CONTAINS CONFIDENTIAL AND PROPRIETARY INFORMATION AND ALL DESIGN, MANUFACTURING, REPRODUCTION, USE, PATENT RIGHTS AND SALES RIGHTS ARE EXPRESSLY RESERVED BY SAMTEC, INC. THIS DOCUMENT SHALL NOT BE DISCLOSED, IN WHOLE OR PART, TO ANY UNAUTHORIZED PERSON OR ENTITY NOR REPRODUCED, TRANSFERRED OR INCORPORATED IN ANY OTHER PROJECT IN ANY MANNER WITHOUT THE EXPRESS WRITTEN CONSENT OF SAMTEC, INC.

MATERIAL: DO NOT SCALE DRAWING SHEET SCALE: 2:1

INSULATOR: LCP, COLOR: BLACK  
 SIGNAL CONTACT: BRASS  
 POWER CONTACT: COPPER ALLOY



520 PARK EAST BLVD, NEW ALBANY, IN 47150  
 PHONE: 812-944-6733 FAX: 812-948-5047  
 e-Mail: info@SAMTEC.com code 53322

DESCRIPTION:	LPHS-RA SOCKET ASSEMBLY
DWG. NO.	LPHS-XX-XX-X-RTX-XX
BY:	ROY LUO 12/13/2011 SHEET 1 OF 7

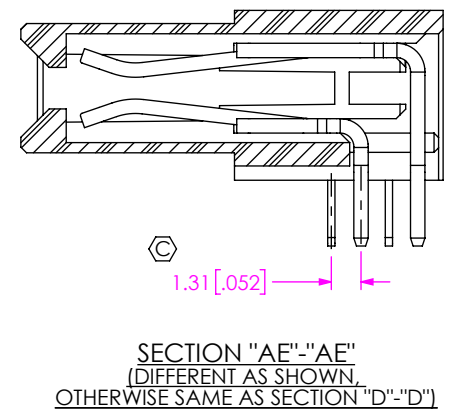
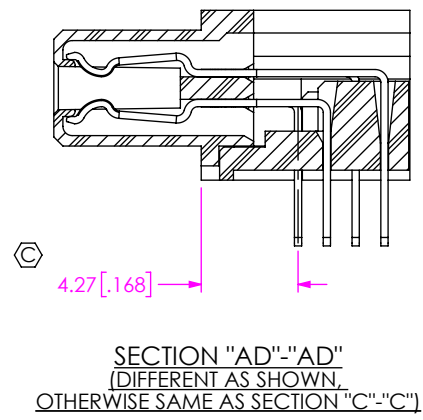
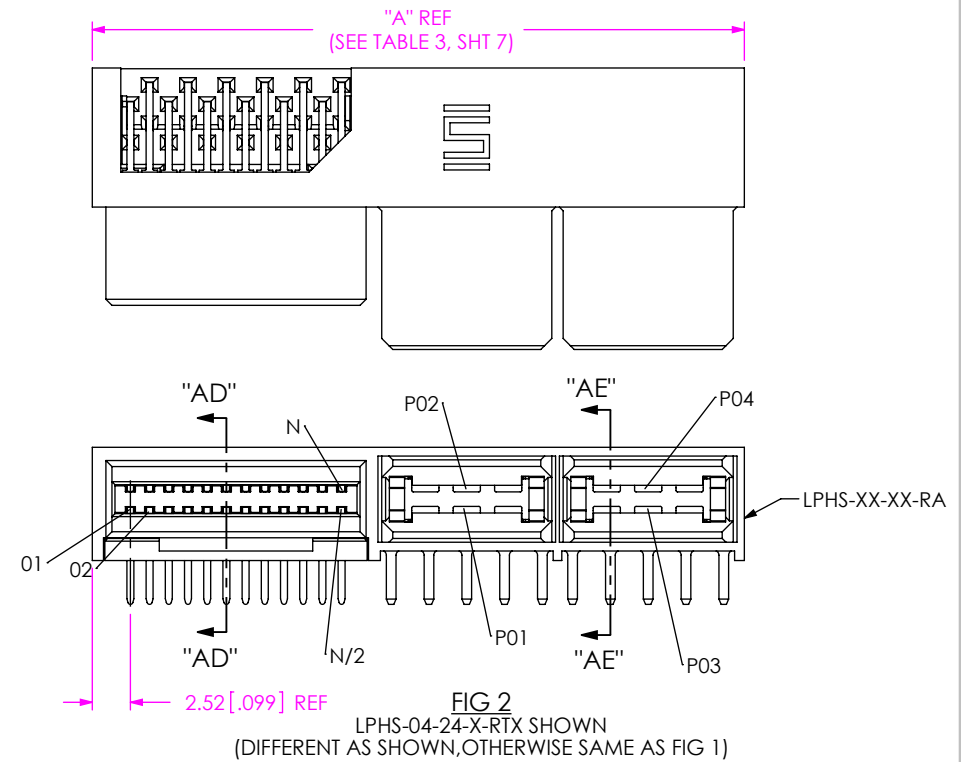
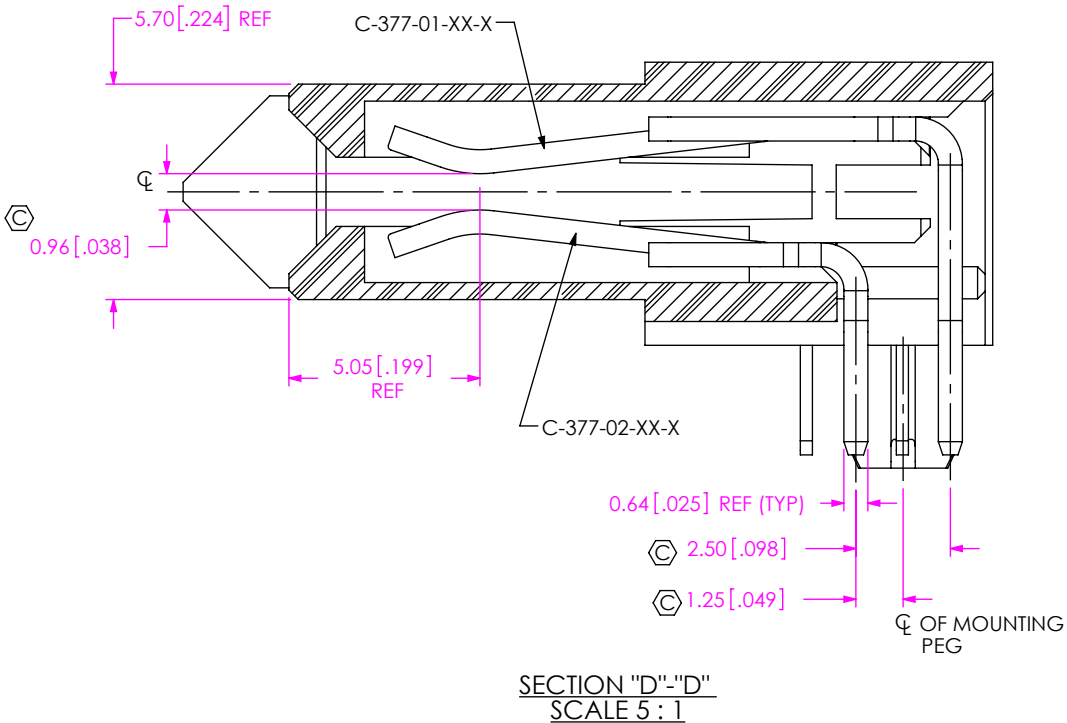
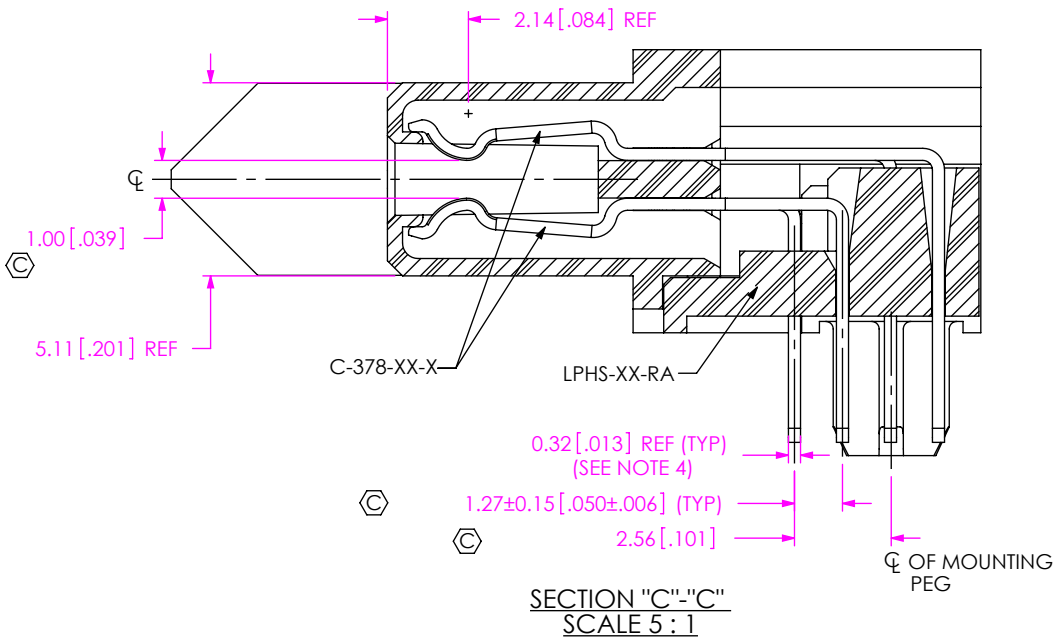

**PROPRIETARY NOTE**  
THIS DOCUMENT CONTAINS CONFIDENTIAL AND PROPRIETARY INFORMATION AND ALL DESIGN, MANUFACTURING, REPRODUCTION, USE, PATENT RIGHTS AND SALES RIGHTS ARE EXPRESSLY RESERVED BY SAMTEC, INC. THIS DOCUMENT SHALL NOT BE DISCLOSED, IN WHOLE OR PART, TO ANY UNAUTHORIZED PERSON OR ENTITY NOR REPRODUCED, TRANSFERRED OR INCORPORATED IN ANY OTHER PROJECT IN ANY MANNER WITHOUT THE EXPRESS WRITTEN CONSENT OF SAMTEC, INC.

DO NOT SCALE DRAWING  
SHEET SCALE: 2:1

**samtec**  
520 PARK EAST BLVD, NEW ALBANY, IN 47150  
PHONE: 812-944-6733 FAX: 812-948-5047  
e-Mail info@SAMTEC.com code 55322

DESCRIPTION:	LPHS-RA SOCKETASSEMBLY
DWG. NO.	LPHS-XX-XX-X-RTX-XX
BY: ROY LUO	12/13/2011 SHEET 2 OF 7

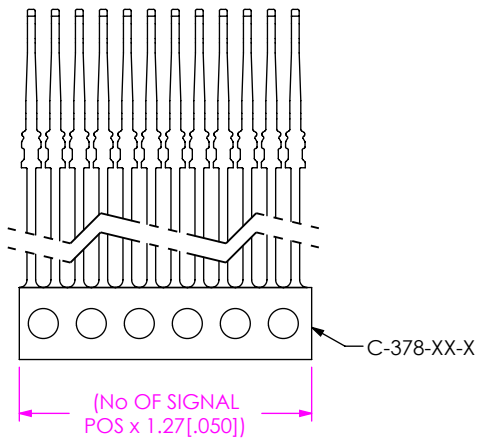

**IN-PROCESS 1**  
CUT COMB & REMOVE TIE BARS FOR C-378-XX-X

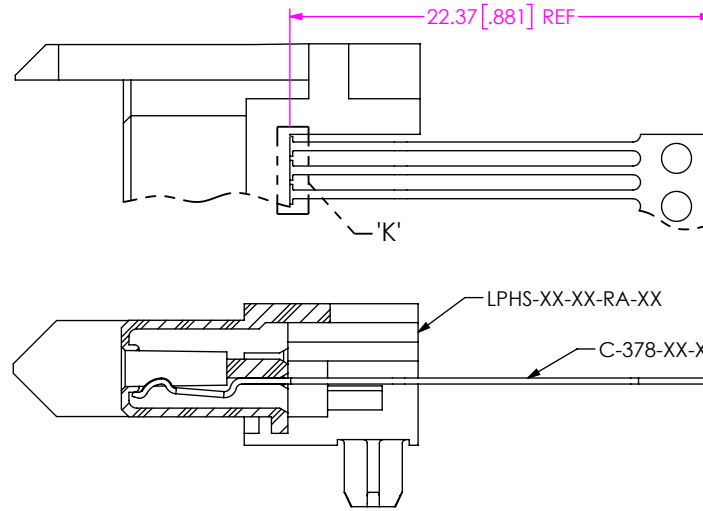

**GP OPTION**

**IN-PROCESS 2**  
FILL SIGNAL BOTTOM ROW

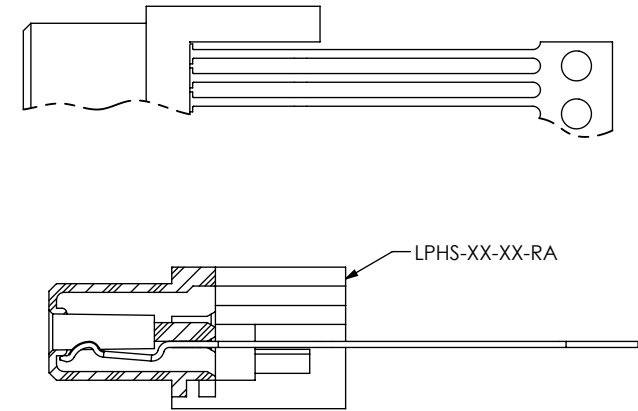

**NO GP OPTION**  
(DIFFERENT AS SHOWN, OTHERWISE SAME AS GP OPTION)

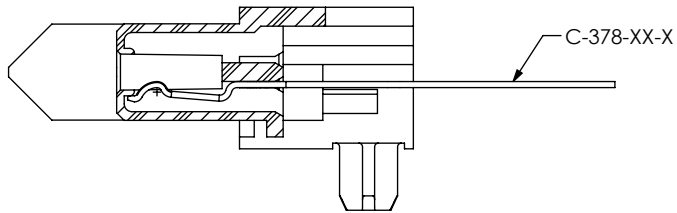
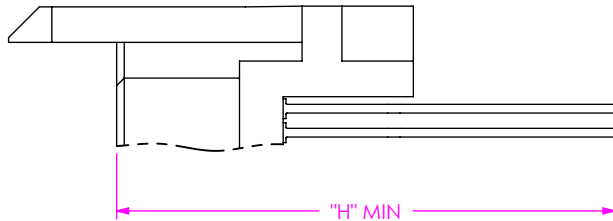

**GP OPTION**

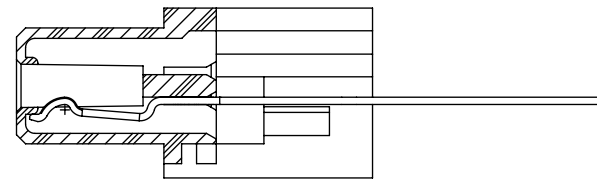
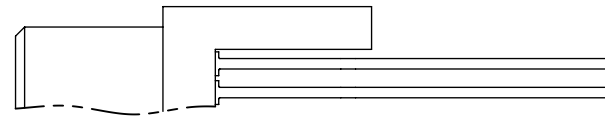

**NO GP OPTION**  
(DIFFERENT AS SHOWN, OTHERWISE SAME AS GP OPTION)

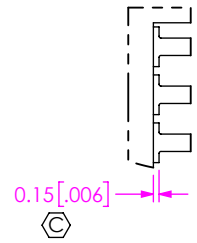

**IN-PROCESS 3**  
CUT OFF CARRIER

TABLE 5	
TAIL	"H"
-RT1	19.36 [.762]
-RT2	20.06 [.790]

**PROPRIETARY NOTE**  
THIS DOCUMENT CONTAINS CONFIDENTIAL AND PROPRIETARY INFORMATION AND ALL DESIGN, MANUFACTURING, REPRODUCTION, USE, PATENT RIGHTS AND SALES RIGHTS ARE EXPRESSLY RESERVED BY SAMTEC, INC. THIS DOCUMENT SHALL NOT BE DISCLOSED, IN WHOLE OR PART, TO ANY UNAUTHORIZED PERSON OR ENTITY NOR REPRODUCED, TRANSFERRED OR INCORPORATED IN ANY OTHER PROJECT IN ANY MANNER WITHOUT THE EXPRESS WRITTEN CONSENT OF SAMTEC, INC.

DO NOT SCALE DRAWING

SHEET SCALE: 2.5:1

**samtec**

520 PARK EAST BLVD, NEW ALBANY, IN 47150  
PHONE: 812-944-6733 FAX: 812-948-5047  
e-Mail info@SAMTEC.com code 55322

DESCRIPTION: LPHS-RA SOCKETASSEMBLY

DWG. NO. LPHS-XX-XX-X-RTX-XX

BY: ROY LUO 12/13/2011 SHEET 3 OF 7

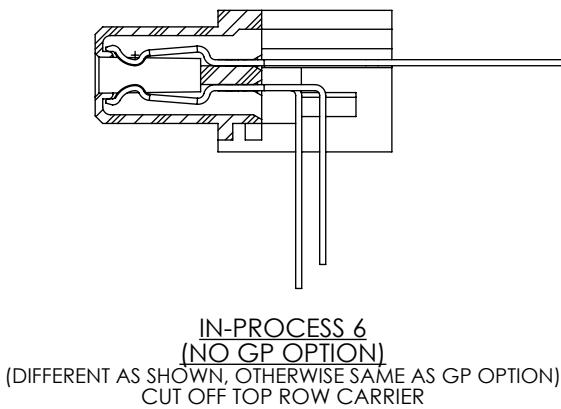
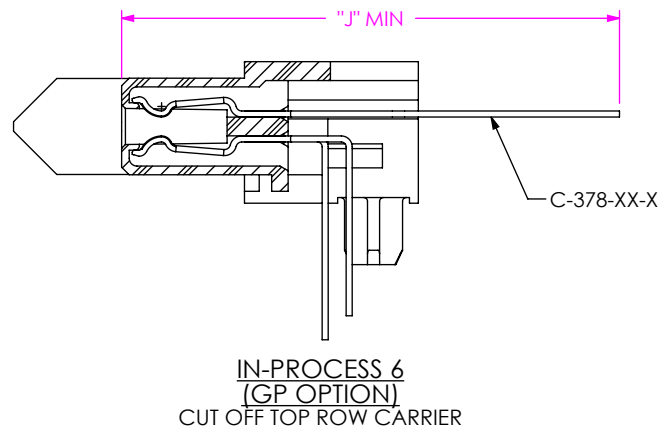
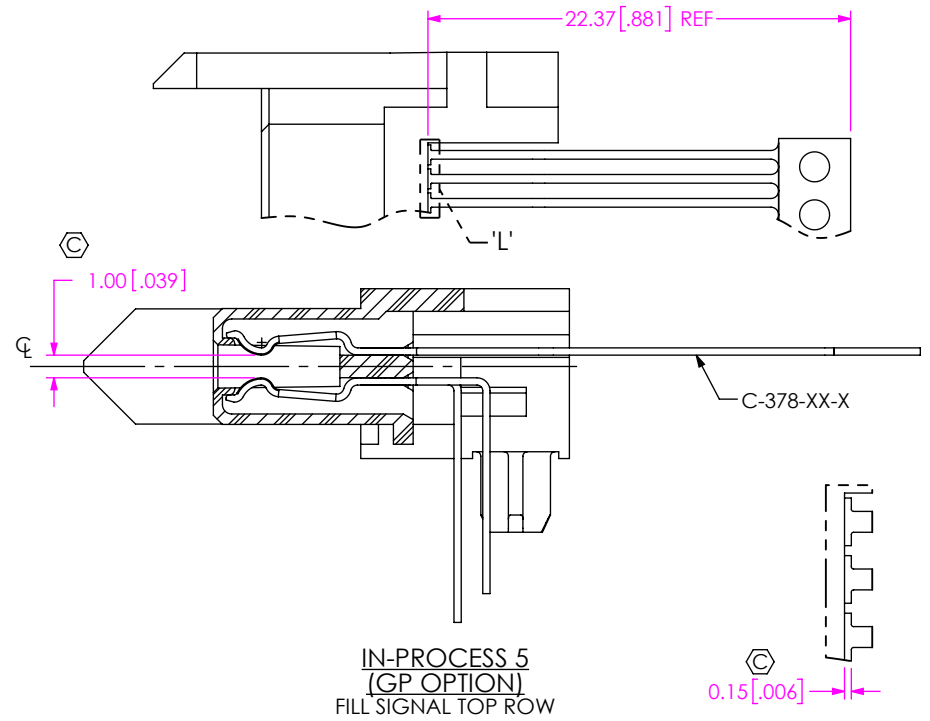
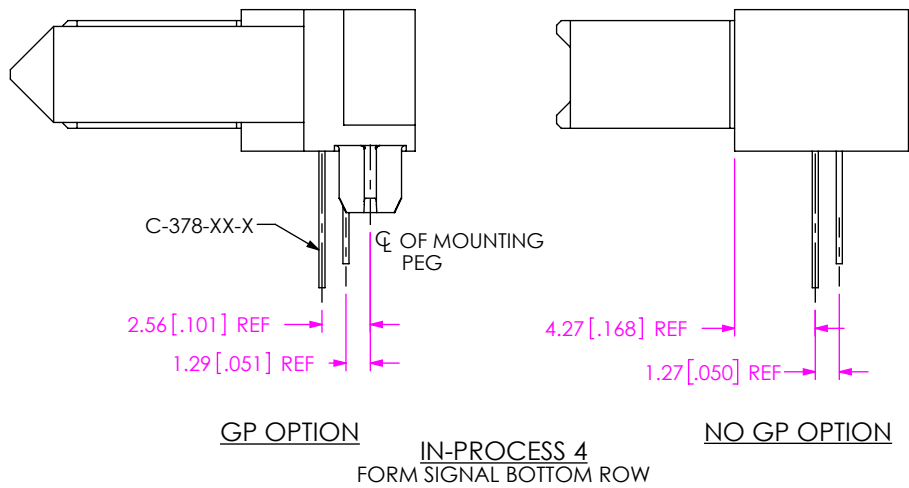
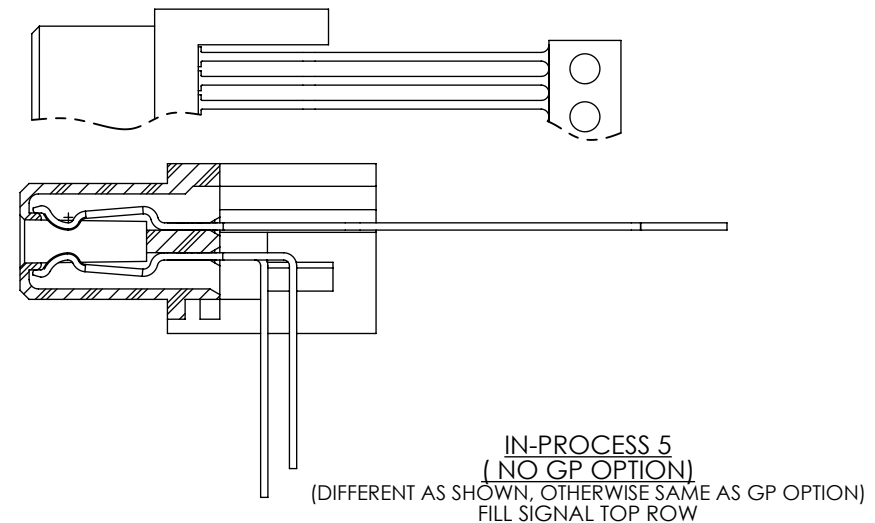

TABLE 6	
TAIL	"J"
-RT1	23.22 [.914]
-RT2	23.92 [.942]



**PROPRIETARY NOTE**  
 THIS DOCUMENT CONTAINS CONFIDENTIAL AND PROPRIETARY INFORMATION AND ALL DESIGN, MANUFACTURING, REPRODUCTION, USE, PATENT RIGHTS AND SALES RIGHTS ARE EXPRESSLY RESERVED BY SAMTEC, INC. THIS DOCUMENT SHALL NOT BE DISCLOSED, IN WHOLE OR PART, TO ANY UNAUTHORIZED PERSON OR ENTITY NOR REPRODUCED, TRANSFERRED OR INCORPORATED IN ANY OTHER PROJECT IN ANY MANNER WITHOUT THE EXPRESS WRITTEN CONSENT OF SAMTEC, INC.

DO NOT SCALE DRAWING

SHEET SCALE: 2.5:1

**samtec**  
 520 PARK EAST BLVD, NEW ALBANY, IN 47150  
 PHONE: 812-944-6733 FAX: 812-948-5047  
 e-Mail: info@SAMTEC.com code 55322

DESCRIPTION:  
 LPHS-RA SOCKETASSEMBLY

DWG. NO.  
**LPHS-XX-XX-X-RTX-XX**

BY: ROY LUO 12/13/2011 SHEET 4 OF 7

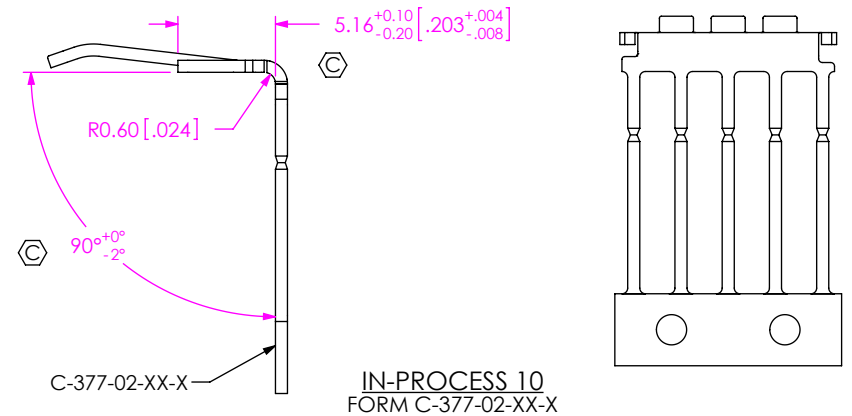
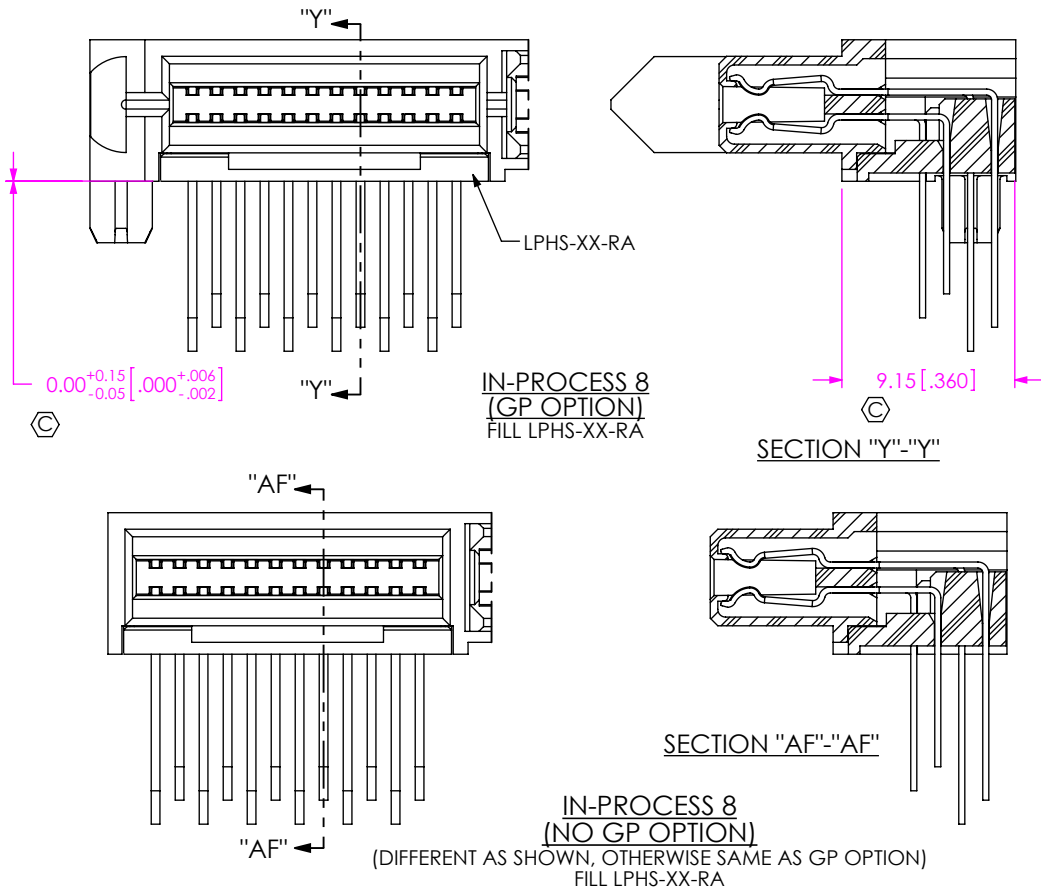
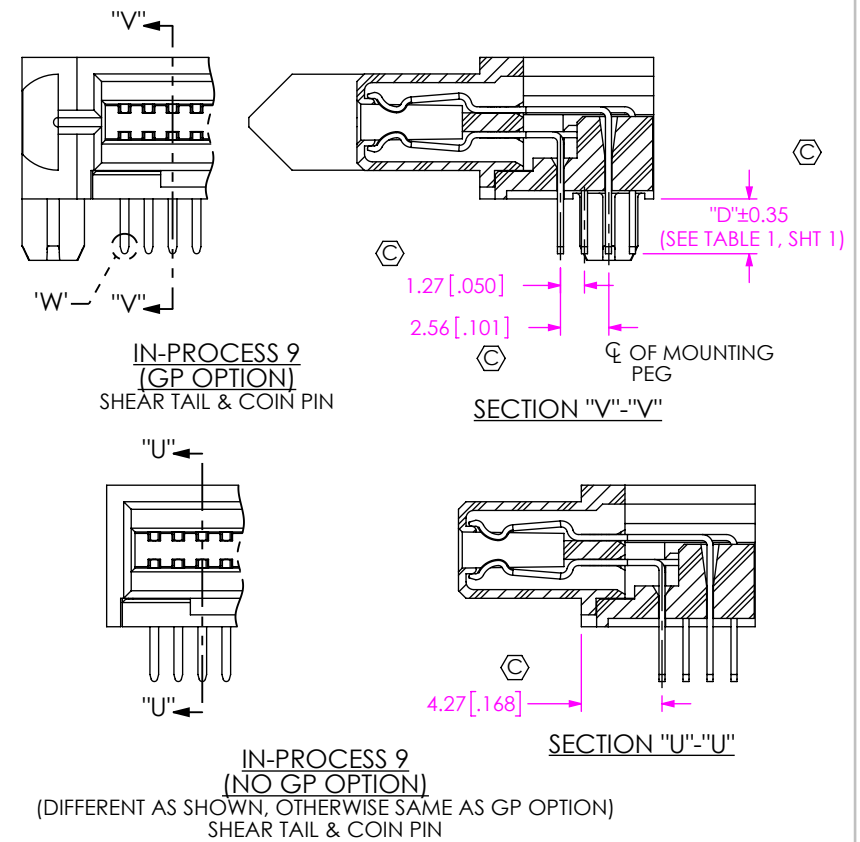
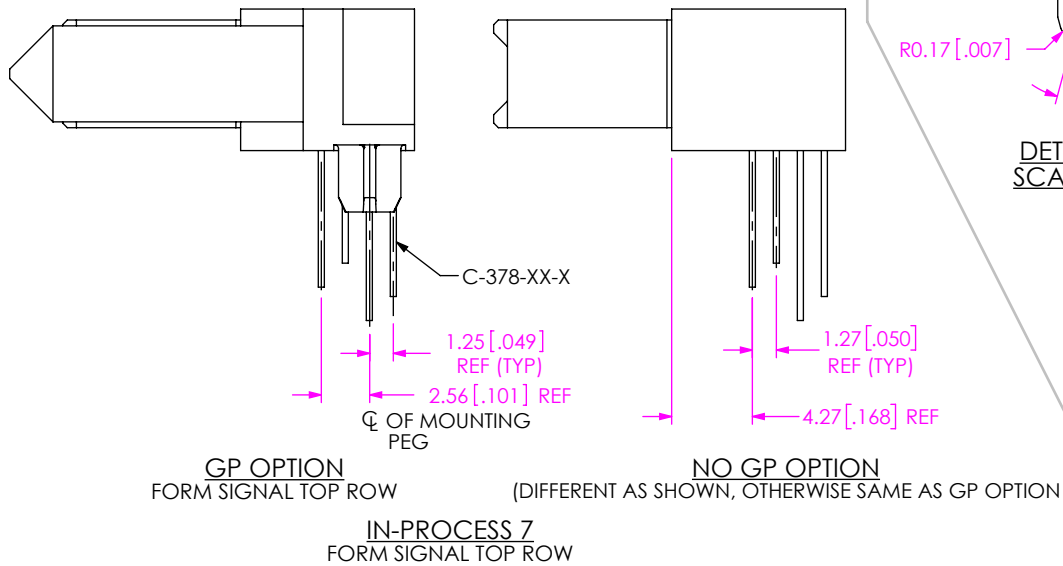

**PROPRIETARY NOTE**  
THIS DOCUMENT CONTAINS CONFIDENTIAL AND PROPRIETARY INFORMATION AND ALL DESIGN, MANUFACTURING, REPRODUCTION, USE, PATENT RIGHTS AND SALES RIGHTS ARE EXPRESSLY RESERVED BY SAMTEC, INC. THIS DOCUMENT SHALL NOT BE DISCLOSED, IN WHOLE OR PART, TO ANY UNAUTHORIZED PERSON OR ENTITY NOR REPRODUCED, TRANSFERRED OR INCORPORATED IN ANY OTHER PROJECT IN ANY MANNER WITHOUT THE EXPRESS WRITTEN CONSENT OF SAMTEC, INC.

DO NOT SCALE DRAWING  
SHEET SCALE: 2.5:1

**samtec**  
520 PARK EAST BLVD, NEW ALBANY, IN 47150  
PHONE: 812-944-6733 FAX: 812-948-5047  
e-Mail info@SAMTEC.com code 55322

DESCRIPTION: LPHS-RA SOCKETASSEMBLY  
DWG. NO. LPHS-XX-XX-X-RTX-XX  
BY: ROY LUO 12/13/2011 SHEET 5 OF 7

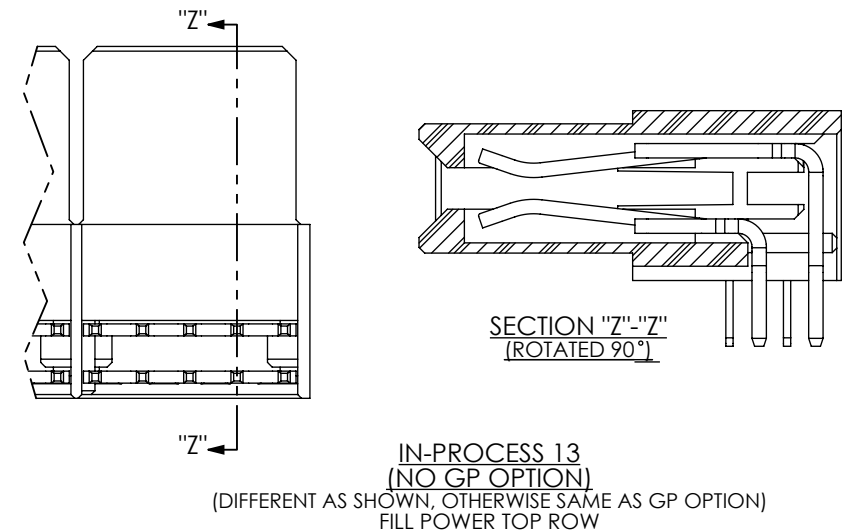
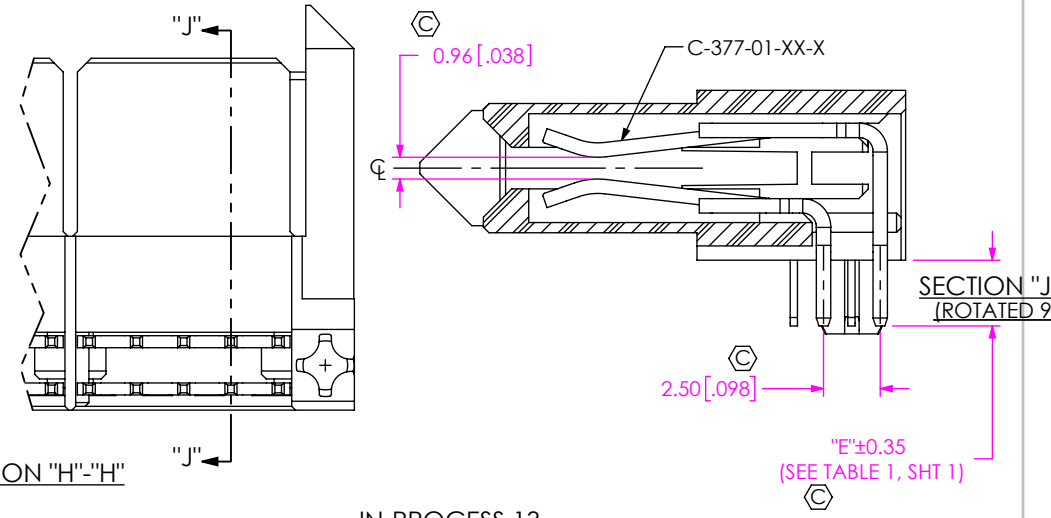
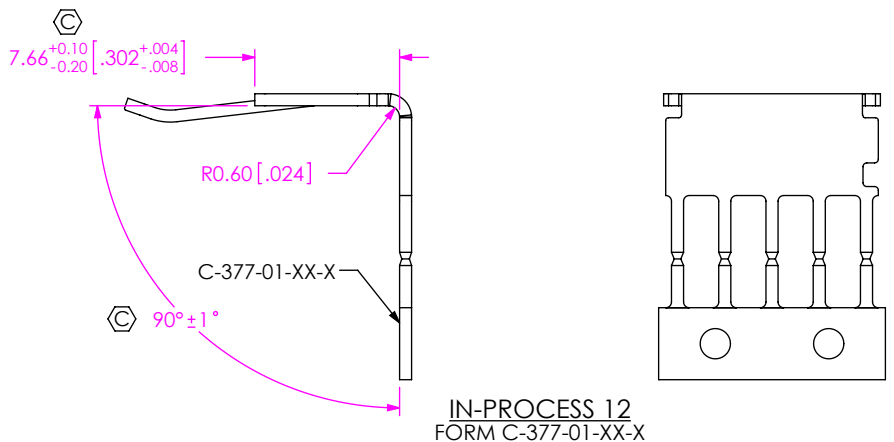
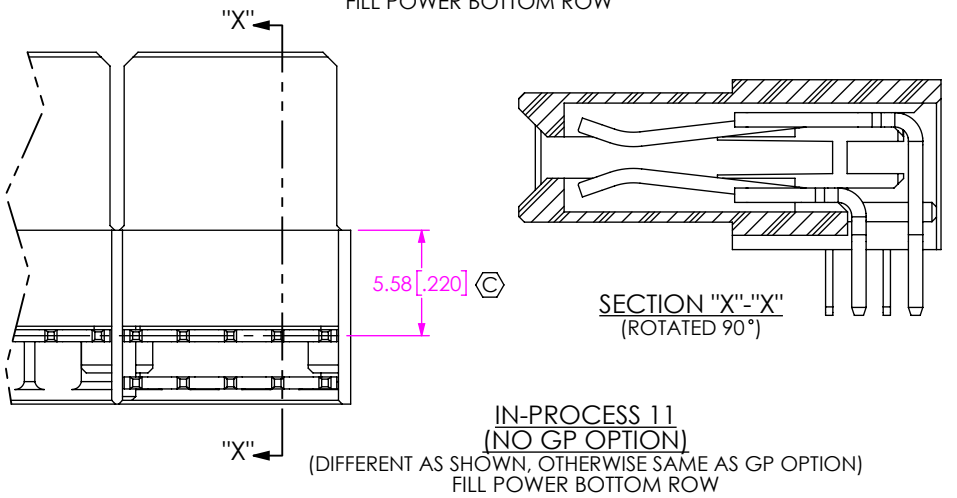
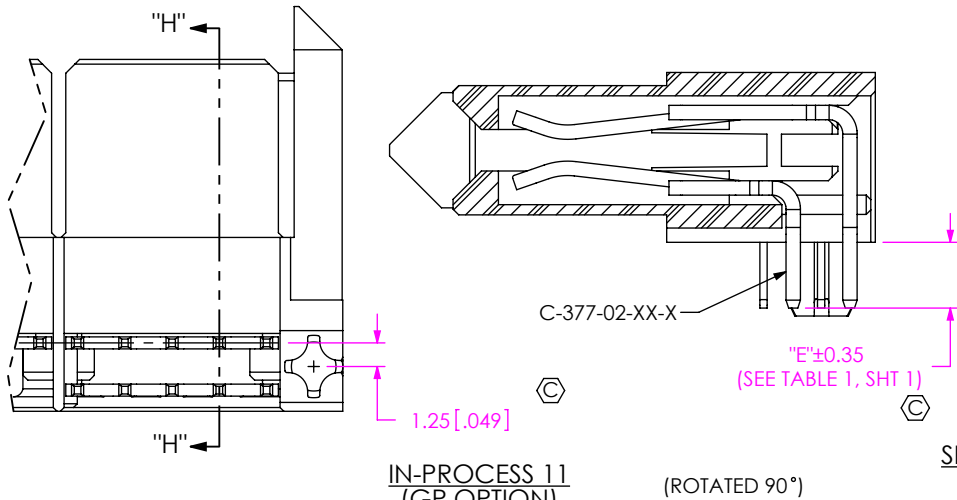

**PROPRIETARY NOTE**  
THIS DOCUMENT CONTAINS CONFIDENTIAL AND PROPRIETARY INFORMATION AND ALL DESIGN, MANUFACTURING, REPRODUCTION, USE, PATENT RIGHTS AND SALES RIGHTS ARE EXPRESSLY RESERVED BY SAMTEC, INC. THIS DOCUMENT SHALL NOT BE DISCLOSED, IN WHOLE OR IN PART, TO ANY UNAUTHORIZED PERSON OR ENTITY NOR REPRODUCED, TRANSFERRED OR INCORPORATED IN ANY OTHER PROJECT IN ANY MANNER WITHOUT THE EXPRESS WRITTEN CONSENT OF SAMTEC, INC.

DO NOT SCALE DRAWING

SHEET SCALE: 2.5:1

**samtec**

520 PARK EAST BLVD. NEW ALBANY, IN 47150  
PHONE: 812-944-6733 FAX: 812-948-5047  
e-Mail: info@SAMTEC.com code 55322

DESCRIPTION: LPHS-RA SOCKETASSEMBLY

DWG. NO. LPHS-XX-XX-X-RTX-XX

BY: ROY LUO 12/13/2011 SHEET 6 OF 7

**TABLE 2 SIGNAL/POWER COMBO -A-GP**

SIGNAL POS	02 POWER POS			04 POWER POS			06 POWER POS			08 POWER POS		
	"A"	"B"	"C"	"A"	"B"	"C"	"A"	"B"	"C"	"A"	"B"	"C"
12	29.09 [1.145]	24.60 [0.969]	25.90 [1.020]	41.09 [1.618]	36.60 [1.441]	37.90 [1.492]	53.09 [2.090]	48.60 [1.913]	49.90 [1.965]	65.09 [2.563]	60.60 [2.386]	61.90 [2.437]
16	31.63 [1.245]	27.14 [1.069]	28.44 [1.120]	43.63 [1.718]	39.14 [1.541]	40.44 [1.592]	55.63 [2.190]	51.14 [2.013]	52.44 [2.065]	67.63 [2.663]	63.14 [2.486]	64.44 [2.537]
20	34.17 [1.345]	29.68 [1.169]	30.98 [1.220]	46.17 [1.818]	41.68 [1.641]	42.98 [1.692]	58.17 [2.290]	53.68 [2.113]	54.98 [2.165]	70.17 [2.763]	65.68 [2.586]	66.98 [2.637]
24	36.71 [1.445]	32.22 [1.269]	33.52 [1.320]	48.71 [1.918]	44.22 [1.741]	45.52 [1.792]	60.71 [2.390]	56.22 [2.213]	57.52 [2.265]	72.71 [2.863]	68.22 [2.686]	69.52 [2.737]
28	39.25 [1.545]	34.76 [1.369]	36.06 [1.420]	51.25 [2.018]	46.76 [1.841]	48.06 [1.892]	63.25 [2.490]	58.76 [2.313]	60.06 [2.365]	75.25 [2.963]	70.76 [2.786]	72.06 [2.837]
32	41.79 [1.645]	37.30 [1.469]	38.60 [1.520]	53.79 [2.118]	49.30 [1.941]	50.60 [1.992]	65.79 [2.590]	61.30 [2.413]	62.60 [2.465]	77.79 [3.063]	73.30 [2.886]	74.60 [2.937]
36	44.33 [1.745]	39.84 [1.569]	41.14 [1.620]	56.33 [2.218]	51.84 [2.041]	53.14 [2.092]	68.33 [2.690]	63.84 [2.513]	65.14 [2.565]	80.33 [3.163]	75.84 [2.986]	77.14 [3.037]
40	46.87 [1.845]	42.38 [1.669]	43.68 [1.720]	58.87 [2.318]	54.38 [2.141]	55.68 [2.192]	70.87 [2.790]	66.38 [2.613]	67.68 [2.665]	82.87 [3.263]	78.38 [3.086]	79.68 [3.137]

**TABLE 2 SIGNAL/POWER COMBO -A-GP CONTINUED**

SIGNAL POS	10 POWER POS			12 POWER POS			14 POWER		
	"A"	"B"	"C"	"A"	"B"	"C"	"A"	"B"	"C"
12	77.09 [3.035]	72.60 [2.858]	73.90 [2.909]	89.09 [3.507]	84.60 [3.331]	85.90 [3.382]	101.09 [3.980]	96.60 [3.803]	97.90 [3.854]
16	79.63 [3.135]	75.14 [2.958]	76.44 [3.009]	91.63 [3.607]	87.14 [3.431]	88.44 [3.482]	103.63 [4.080]	99.14 [3.903]	100.44 [3.954]
20	82.17 [3.235]	77.68 [3.058]	78.98 [3.109]	94.17 [3.707]	89.68 [3.531]	90.98 [3.582]	106.17 [4.180]	101.68 [4.003]	102.98 [4.054]
24	84.71 [3.335]	80.22 [3.158]	81.52 [3.209]	96.71 [3.807]	92.22 [3.631]	93.52 [3.682]	108.71 [4.280]	104.22 [4.103]	105.52 [4.154]
28	87.25 [3.435]	82.76 [3.258]	84.06 [3.309]	99.25 [3.907]	94.76 [3.731]	96.06 [3.782]	111.25 [4.380]	106.76 [4.203]	108.06 [4.254]
32	89.79 [3.535]	85.30 [3.358]	86.60 [3.409]	101.79 [4.007]	97.30 [3.831]	98.60 [3.882]	113.79 [4.480]	109.30 [4.303]	110.60 [4.354]
36	92.33 [3.635]	87.84 [3.458]	89.14 [3.509]	104.33 [4.107]	99.84 [3.931]	101.14 [3.982]	116.33 [4.580]	111.84 [4.403]	113.14 [4.454]
40	94.87 [3.735]	90.38 [3.558]	91.68 [3.609]	106.87 [4.207]	102.38 [4.031]	103.68 [4.082]	118.87 [4.680]	114.38 [4.503]	115.68 [4.554]

**TABLE 3 SIGNAL/POWER COMBO NO -GP OPTIONS**

SIGNAL POS	02 POWER	04 POWER	06 POWER	08 POWER	10 POWER	12 POWER	14 POWER
	"A"	"A"	"A"	"A"	"A"	"A"	"A"
12	23.51 [0.926]	35.51 [1.398]	47.51 [1.870]	59.51 [2.343]	71.51 [2.815]	83.51 [3.288]	95.51 [3.760]
16	26.05 [1.026]	38.05 [1.498]	50.05 [1.970]	62.05 [2.443]	74.05 [2.915]	86.05 [3.388]	98.05 [3.860]
20	28.59 [1.126]	40.59 [1.598]	52.59 [2.070]	64.59 [2.543]	76.59 [3.015]	88.59 [3.488]	100.59 [3.960]
24	31.13 [1.226]	43.13 [1.698]	55.13 [2.170]	67.13 [2.643]	79.13 [3.115]	91.13 [3.588]	103.13 [4.060]
28	33.67 [1.326]	45.67 [1.798]	57.67 [2.270]	69.67 [2.743]	81.67 [3.215]	93.67 [3.688]	105.67 [4.160]
32	36.21 [1.426]	48.21 [1.898]	60.21 [2.370]	72.21 [2.843]	84.21 [3.315]	96.21 [3.788]	108.21 [4.260]
36	38.75 [1.526]	50.75 [1.998]	62.75 [2.470]	74.75 [2.943]	86.75 [3.415]	98.75 [3.888]	110.75 [4.360]
40	41.29 [1.626]	53.29 [2.098]	65.29 [2.570]	77.29 [3.043]	89.29 [3.515]	101.29 [3.988]	113.29 [4.460]

**TABLE 4**

SIGNAL POS	"F"	"G"
12	6.35 [0.250]	6.35 [0.250]
16	8.89 [0.350]	8.89 [0.350]
20	11.43 [0.450]	11.43 [0.450]
24	13.97 [0.550]	13.97 [0.550]
28	16.51 [0.650]	16.51 [0.650]
32	19.05 [0.750]	19.05 [0.750]
36	21.59 [0.850]	21.59 [0.850]
40	24.13 [0.950]	24.13 [0.950]

**PROPRIETARY NOTE**

THIS DOCUMENT CONTAINS CONFIDENTIAL AND PROPRIETARY INFORMATION AND ALL DESIGN, MANUFACTURING, REPRODUCTION, USE, PATENT RIGHTS AND SALES RIGHTS ARE EXPRESSLY RESERVED BY SAMTEC, INC. THIS DOCUMENT SHALL NOT BE DISCLOSED, IN WHOLE OR PART, TO ANY UNAUTHORIZED PERSON OR ENTITY NOR REPRODUCED, TRANSFERRED OR INCORPORATED IN ANY OTHER PROJECT IN ANY MANNER WITHOUT THE EXPRESS WRITTEN CONSENT OF SAMTEC, INC.

DO NOT SCALE DRAWING

SHEET SCALE: 2:1



520 PARK EAST BLVD, NEW ALBANY, IN 47150  
 PHONE: 812-944-6733 FAX: 812-948-5047  
 e-Mail info@SAMTEC.com code 55322

DESCRIPTION: LPHS-RA SOCKETASSEMBLY

DWG. NO. LPHS-XX-XX-X-RTX-XX

BY: ROY LUO 12/13/2011 SHEET 7 OF 7