

DESIGNED & DIMENSIONED
IN MILLIMETERS [INCHES]

MCR-8-02-X-XX.XX-X-XX

DO NOT
SCALE FROM
THIS PRINT

RECEPTACLE
SIZE

LEAD STYLE
-02: 12 POS, 28 AWG

PLATING SPECIFICATION
-L: 10µ" GOLD IN CONTACT AREA

END 2 (SEE TABLE 1)
-BC: BLUNT CUT
-01: 2 x 6 SFSD
(PIN 1 TO PIN 1)

END 1
-S: SOCKET

ASSEMBLED LENGTH
XX.XX (IN METERS)
(0.10 METER MIN TO
50.00 METER MAX)

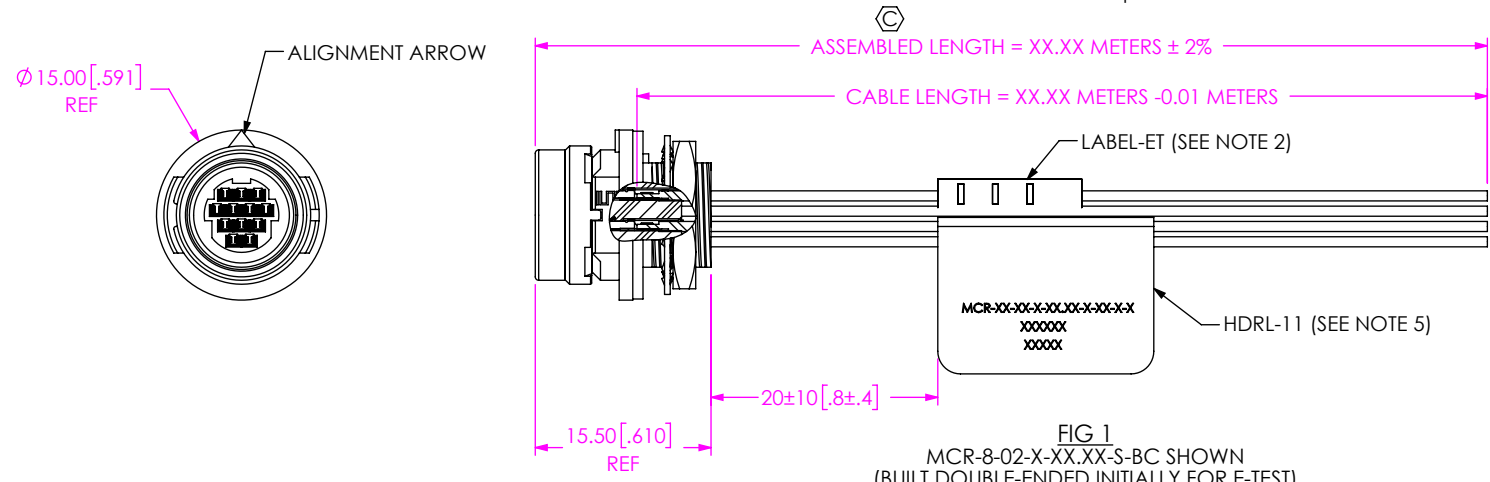

FIG 1
MCR-8-02-X-XX.XX-S-BC SHOWN
(BUILT DOUBLE-ENDED INITIALLY FOR E-TEST)

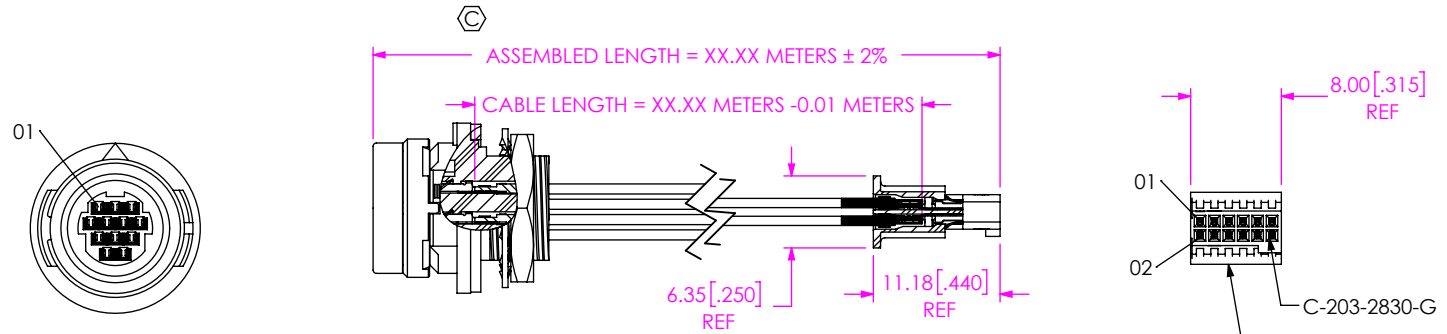
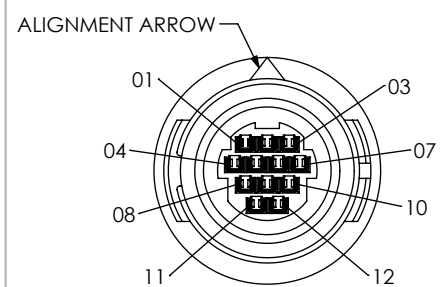

FIG 2
MCR-8-02-X-XX.XX-S-01 SHOWN
(PIN 1 TO PIN 1)
(DIFFERENT AS SHOWN, OTHERWISE SAME AS FIG 1)

END 1 OPTIONS

12 POSITION
(-S: SOCKET)



NOTES:

1. Ⓢ REPRESENTS A CRITICAL DIMENSION.
2. ASSEMBLY TO BE 100% TESTED FOR CONTINUITY, ISOLATION, & HI-POT AT 300V. (1) LABEL-ET TO BE APPLIED AFTER FINAL ELECTRICAL TEST.
3. ASSEMBLIES TO BE BULK PACKAGED PER PACKAGING STANDARD CO-RF-WI-3001-M.
4. SIGNAL MAPPING IS 1 TO 1, 2 TO 2, 3 TO 3, etc..
5. PLACE HDRL-11 (LABEL) ON CABLE WHERE SHOWN. LABEL TO CONTAIN
LINE 1 - PART NUMBER "MCR-8-XX-X-XX.XX-X-XX"
LINE 2 - SHOP ORDER NUMBER "XXXXXX"
LINE 3 - DATE CODE "XXXXX"
6. PANEL THICKNESS RANGE: 0.70[0.027] - 3.00[0.118].
7. WHEN MOUNTING PRODUCT TO PANEL TORQUE PN-30-8 TO 0.8 Nm[7.08 IN-LBS].
8. CONTACTS MUST BE INSERTED UNTIL RETENTION FEATURE LOCKS INTO PLACE.
9. REFER TO CRIMP-SPECIFICATIONS PRINT FOR CRIMP AND STRIP DIMENSIONS, TOLERANCES, TOOLING, AND ITS REQUIREMENTS.
10. -S (SOCKET): REFERENCE DC-MCR-8 PRINT FOR SOCKET DUSTCAP

UNLESS OTHERWISE SPECIFIED, DIMENSIONS ARE IN MILLIMETERS. TOLERANCES ARE: DECIMALS ANGLES X.X: ±0.3 [.01] 2° X.XX: ±0.13 [.005] X.XXX: ±0.051 [.0020]		<p>PROPRIETARY NOTE</p> <p>THIS DOCUMENT CONTAINS CONFIDENTIAL AND PROPRIETARY INFORMATION AND ALL DESIGN, MANUFACTURING, REPRODUCTION, USE, PATENT RIGHTS AND SALES RIGHTS ARE EXPRESSLY RESERVED BY SAMTEC, INC. THIS DOCUMENT SHALL NOT BE DISCLOSED, IN WHOLE OR PART, TO ANY UNAUTHORIZED PERSON OR ENTITY NOR REPRODUCED, TRANSFERRED OR INCORPORATED IN ANY OTHER PROJECT IN ANY MANNER WITHOUT THE EXPRESS WRITTEN CONSENT OF SAMTEC, INC.</p>	
MATERIAL: DO NOT SCALE DRAWING SHEET SCALE: 3:2 INSULATOR, C-RING: PPS CONTACTS: PHOS BRONZE GASKET: NEOPRENE RUBBER LOCK WASHER: PHOS BRONZE, NI PLATED HEX NUT: BRASS, NI PLATED		 <p>520 PARK EAST BLVD., NEW ALBANY, IN 47150 PHONE: 812-944-6733 FAX: 812-948-5047 e-Mail: info@SAMTEC.com code 53322</p>	
DESCRIPTION: MINI CIRC. PANEL ASSEMBLY		DWG. NO. MCR-8-02-X-XX.XX-X-XX	
BY: J. BORGELT 4/11/2013		SHEET 1 OF 2	

REVISION E

IN-PROCESS 1
 CUT CABLE TO LENGTH SHOWN
 (CABLE LENGTH FORMULA HAS ADDER
 FOR BUILDING CABLE DOUBLE ENDED)
 (SEE NOTE 6)

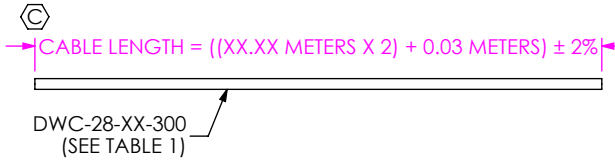

TABLE 1				
POSITION	-BC		-01	
	COLOR	DWC-XX-XX-XXX	COLOR	DWC-XX-XX-XXX
01	BROWN	DWC-28-01-300	BLACK	DWC-28-10-300
02	RED	DWC-28-02-300	BLACK	DWC-28-10-300
03	ORANGE	DWC-28-03-300	BLACK	DWC-28-10-300
04	YELLOW	DWC-28-04-300	BLACK	DWC-28-10-300
05	GREEN	DWC-28-05-300	BLACK	DWC-28-10-300
06	DARK BLUE	DWC-28-06-300	BLACK	DWC-28-10-300
07	VIOLET	DWC-28-07-300	BLACK	DWC-28-10-300
08	GRAY	DWC-28-08-300	BLACK	DWC-28-10-300
09	WHITE	DWC-28-09-300	BLACK	DWC-28-10-300
10	BLACK	DWC-28-10-300	BLACK	DWC-28-10-300
11	GREEN/BLACK	DWC-28-11-300	BLACK	DWC-28-10-300
12	TAN	DWC-28-12-300	BLACK	DWC-28-10-300

IN-PROCESS 2
 STRIP CONDUCTORS



IN-PROCESS 3
 CRIMP CONTACTS
 (SEE NOTE 9)



IN-PROCESS 4
 SLIDE PG-30-8, LW-30-8, & PN-30-8 COMPONENTS ONTO WIRES

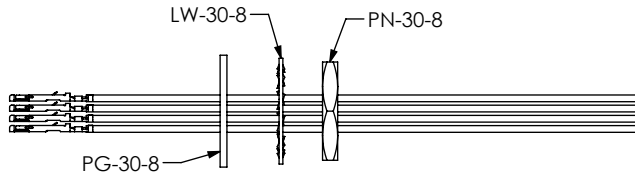

IN-PROCESS 5
 INSERT CONTACTS INTO SUB-MCR-8-12 INSULATOR
 UNTIL THEIR RETENTION FEATURES LOCK INTO PLACE.

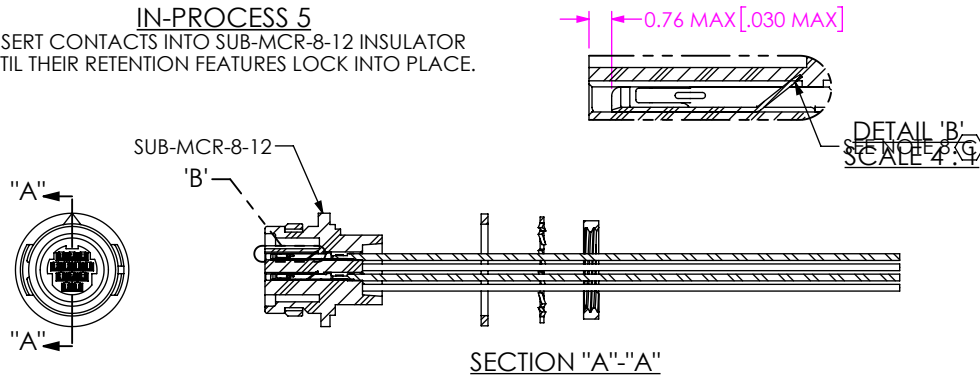

IN-PROCESS 6

SLIDE PG-30-8 FORWARD AND SEAT AGAINST FLANGE ON
 SUB-MCR-8-12. SLIDE LW-30-8 FORWARD & LOOSELY THREAD
 PN-30-8 ONTO SUB-MCR-8-12 TO HOLD ITEMS IN PLACE



IN-PROCESS 7

REPEAT STEPS 2-6 FOR END 2, E-TEST CABLE, APPLY
 LABEL-ET & HDRL-11 TO BOTH ENDS, CUT CABLE IN
 HALF & TRIM BOTH ENDS TO FINISHED LENGTH.

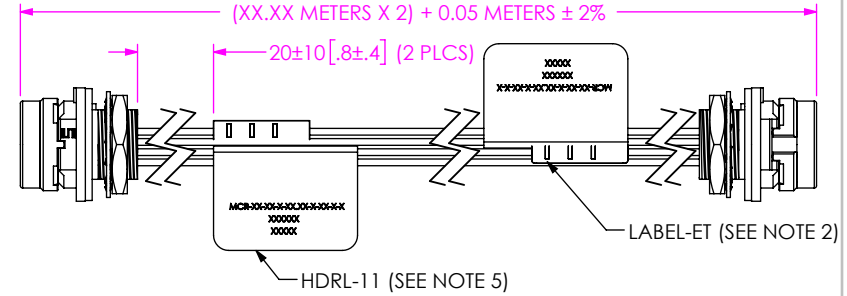

RECOMMENDED PANEL OPENING
 (SEE NOTES 6 & 7)

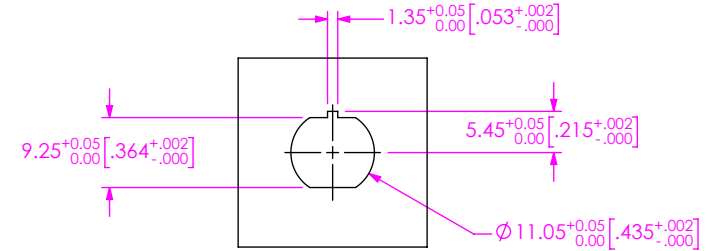

PROPRIETARY NOTE
 THIS DOCUMENT CONTAINS CONFIDENTIAL AND
 PROPRIETARY INFORMATION AND ALL DESIGN,
 MANUFACTURING, REPRODUCTION, USE, PATENT RIGHTS
 AND SALES RIGHTS ARE EXPRESSLY RESERVED BY SAMTEC,
 INC. THIS DOCUMENT SHALL NOT BE DISCLOSED, IN WHOLE
 OR PART, TO ANY UNAUTHORIZED PERSON OR ENTITY NOR
 REPRODUCED, TRANSFERRED OR INCORPORATED IN ANY
 OTHER PROJECT IN ANY MANNER WITHOUT THE EXPRESS
 WRITTEN CONSENT OF SAMTEC, INC.

DO NOT SCALE DRAWING

SHEET SCALE: 1:1



520 PARK EAST BLVD, NEW ALBANY, IN 47150
 PHONE: 812-944-6733 FAX: 812-948-5047
 e-Mail info@SAMTEC.com code 55322

DESCRIPTION:
 MINI CIRC. PANEL ASSEMBLY

DWG. NO.
 MCR-8-02-X-XX.XX-X-XX

BY: J. BORGELT 4/11/2013 SHEET 2 OF 2