

**DESIGNED & DIMENSIONED
IN MILLIMETERS(INCHES)**

DO NOT
SCALE FROM
THIS PRINT

ITEM	COMPONENT	-H
1	SUB ASSEMBLY	SUB-MCX-J-C-F-ST-CA2
2	SOCKET	MCX-SKT-002-H
3	INSULATOR	MCX-INS-002
4	INNER FERRULE	MCX-FER-003-F
5	OUTER FERRULE	MCX-FER-004-F

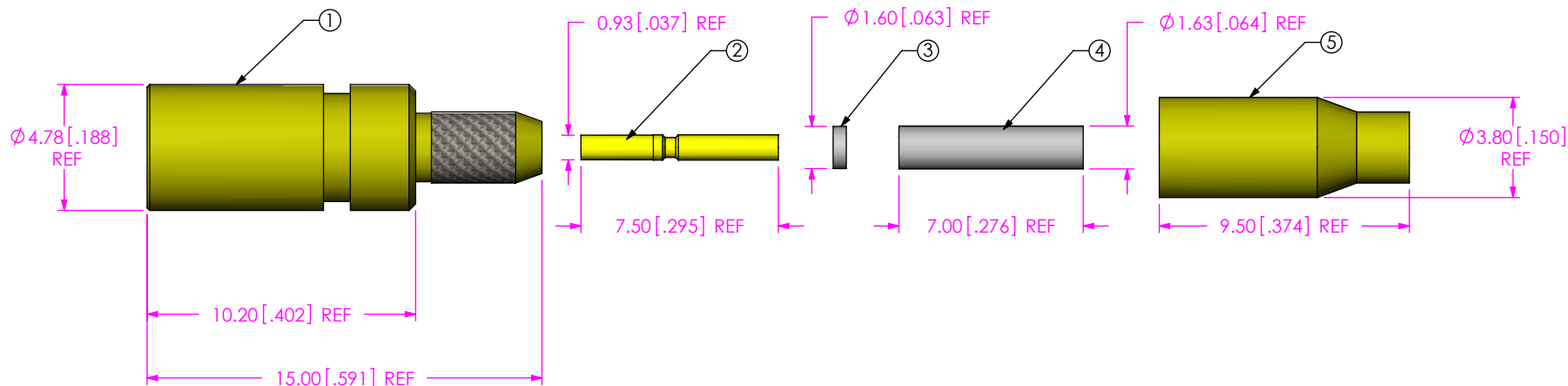
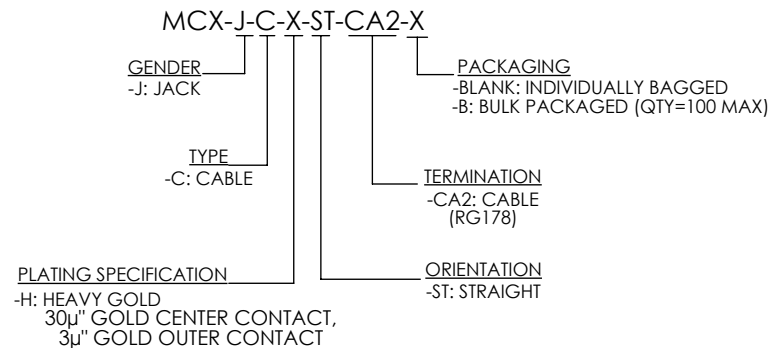

NOTES:

1. NOTE DELETED.
2. NOTE DELETED.
3. NOTE DELETED.
4. NOTE DELETED.
5. PRODUCT TO BE PACKAGED PER PRECISION RF SECTION OF PACKAGING MANUAL.
6. NOTE DELETED.
7. NOTE DELETED.
8. NOTE DELETED.

F:\DWG\MISC\MKTG\MCX-J-C-X-ST-CA2-X-MKT.SLDDRW

UNLESS OTHERWISE SPECIFIED,
DIMENSIONS ARE IN
MILLIMETERS [INCHES].
TOLERANCES ARE:
DECIMALS ANGLES
.X: ±0.3 [.01] 5°
.XX: ±0.13 [.005]
.XXX: ±0.051 [.0020]

PROPRIETARY NOTE
* THIS DOCUMENT CONTAINS CONFIDENTIAL AND PROPRIETARY INFORMATION AND ALL DESIGN, MANUFACTURING, REPRODUCTION, USE, PATENT RIGHTS AND SALES RIGHTS ARE EXPRESSLY RESERVED BY SAMTEC, INC. THIS DOCUMENT SHALL NOT BE DISCLOSED, IN WHOLE OR PART, TO ANY UNAUTHORIZED PERSON OR ENTITY NOR REPRODUCED, TRANSFERRED OR INCORPORATED IN ANY OTHER PROJECT IN ANY MANNER WITHOUT THE EXPRESS WRITTEN CONSENT OF SAMTEC, INC.

MATERIAL: DO NOT SCALE DRAWING SHEET SCALE: 4:1

SHELL, FERRULE: BRASS
CONTACT: COPPER ALLOY
DIELECTRIC: PTFE



520 PARK EAST BLVD, NEW ALBANY, IN 47150
PHONE: 812-944-6733 FAX: 812-948-5047
e-Mail: info@SAMTEC.com code: 55322

DESCRIPTION:
50 OHM MCX STRAIGHT CABLE JACK, RG178

DWG. NO.
MCX-J-C-X-ST-CA2-X

BY: R MUSSER 02/06/2008 SHEET 1 OF 3

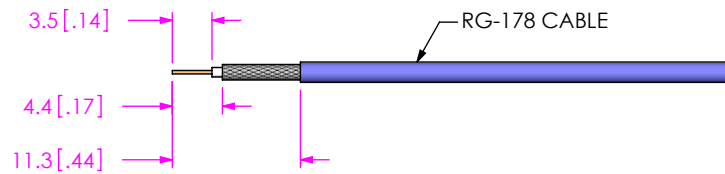

IN-PROCESS 1
STRIP CABLE AND TIN INNER
CONDUCTOR

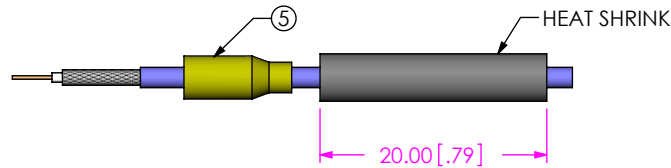

IN-PROCESS 2
ADD HEAT SHRINK TUBING AND FERRULE

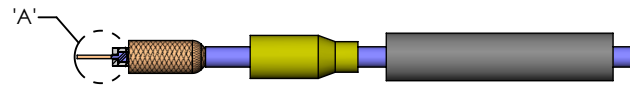
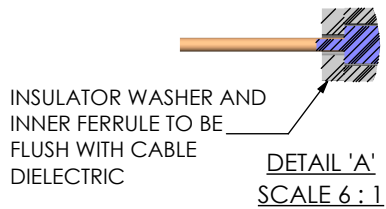

IN-PROCESS 3
FLARE SHIELD AND ADD INNER
FERRULE & INSULATOR

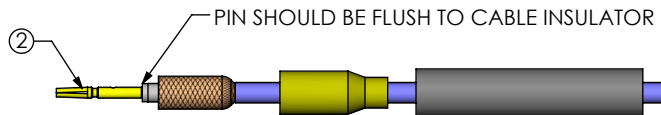

IN-PROCESS 4
SOLDER SIGNAL SOCKET

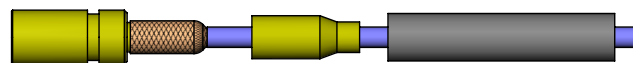

IN-PROCESS 5
FLARE SHIELD, ADD SUB ASSEMBLY

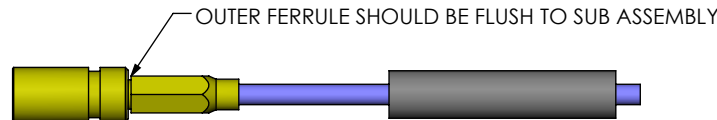

IN-PROCESS 6
CRIMP OUTER FERRULE
(USE RF CRIMP HAND TOOL #CAT-RF-FER-001
USE 0.136" DIE SIZE)



IN-PROCESS 7
ACTIVATE HEAT SHRINK

PROPRIETARY NOTE
* THIS DOCUMENT CONTAINS CONFIDENTIAL AND PROPRIETARY INFORMATION AND ALL DESIGN, MANUFACTURING, REPRODUCTION, USE, PATENT RIGHTS AND SALES RIGHTS ARE EXPRESSLY RESERVED BY SAMTEC, INC. THIS DOCUMENT SHALL NOT BE DISCLOSED, IN WHOLE OR PART, TO ANY UNAUTHORIZED PERSON OR ENTITY NOR REPRODUCED, TRANSFERRED OR INCORPORATED IN ANY OTHER PROJECT IN ANY MANNER WITHOUT THE EXPRESS WRITTEN CONSENT OF SAMTEC, INC.

DO NOT SCALE DRAWING

SHEET SCALE: 1:0.66667



520 PARK EAST BLVD, NEW ALBANY, IN 47150
PHONE: 812-944-6733 FAX: 812-948-5047
e-Mail: info@SAMTEC.com code: 55322

DESCRIPTION:
50 OHM MCX STRAIGHT CABLE JACK, RG178

DWG. NO.
MCX-J-C-X-ST-CA2-X

BY: R MUSSER 02/06/2008 SHEET 2 OF 3

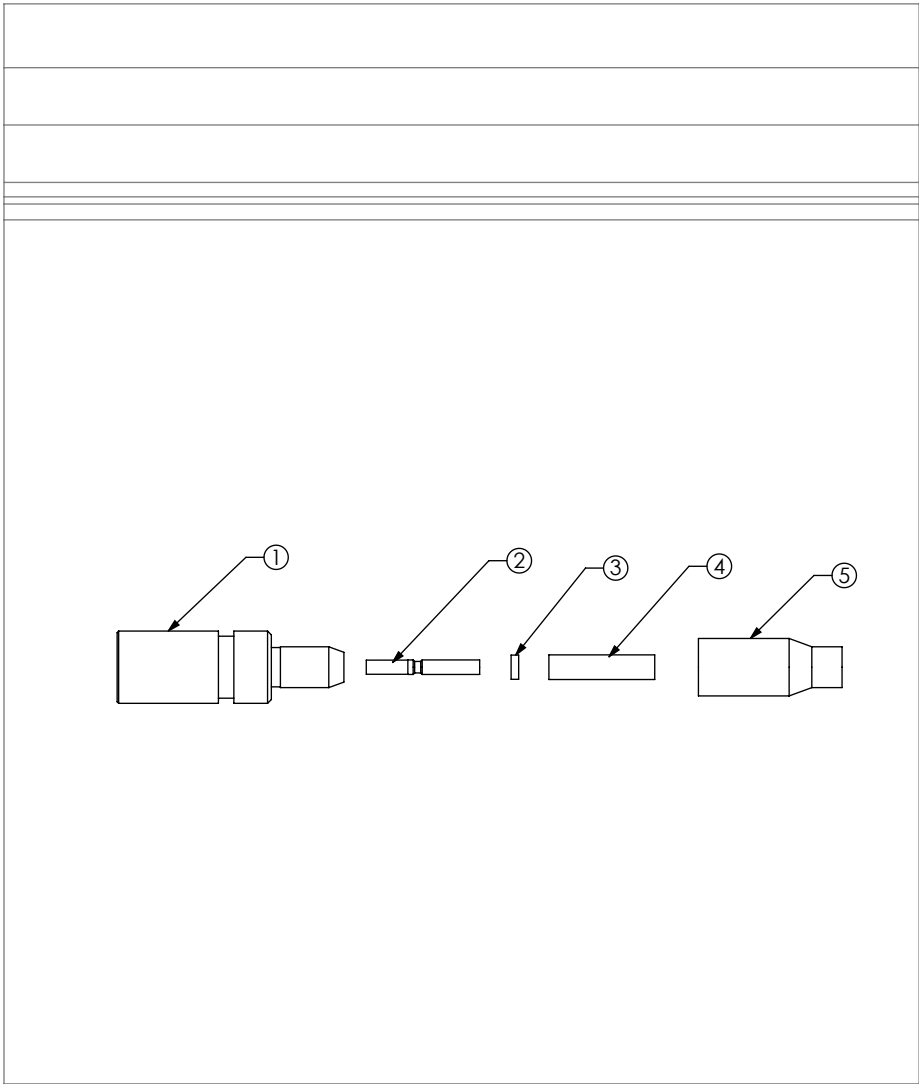

PACKAGING VIEW
MCX-J-C-X-ST-CA2 SHOWN

F:\DWG\MISC\MKTG\MCX-J-C-X-ST-CA2-X-MKT.SLDDRW

<p>PROPRIETARY NOTE</p> <p>THIS DOCUMENT CONTAINS CONFIDENTIAL AND PROPRIETARY INFORMATION AND ALL DESIGN, MANUFACTURING, REPRODUCTION, USE, PATENT RIGHTS AND SALES RIGHTS ARE EXPRESSLY RESERVED BY SAMTEC, INC. THIS DOCUMENT SHALL NOT BE DISCLOSED, IN WHOLE OR PART, TO ANY UNAUTHORIZED PERSON OR ENTITY NOR REPRODUCED, TRANSFERRED OR INCORPORATED IN ANY OTHER PROJECT IN ANY MANNER WITHOUT THE EXPRESS WRITTEN CONSENT OF SAMTEC, INC.</p>	 <p>520 PARK EAST BLVD, NEW ALBANY, IN 47150 PHONE: 812-944-6733 FAX: 812-948-5047 e-Mail: info@SAMTEC.com code: 55322</p>
<p>SHEET SCALE: 1:0.666667</p>	<p>DESCRIPTION: 50 OHM MCX STRAIGHT CABLE JACK, RG178</p> <p>DWG. NO. MCX-J-C-X-ST-CA2-X</p> <p>BY: R MUSSER 02/06/2008 SHEET 3 OF 3</p>