

DO NOT SCALE FROM THIS PRINT

TERMINAL SPEC	PIN #1	PIN #2	PIN #3
-05	T-1S6-21-X-2	N/A	N/A
-06	T-1S6-18-X-2	N/A	N/A
-07	T-1S6-07-X-2	T-1S6-15-X-2	T-1S6-10-X-2
-08	T-1S6-08-X-2	T-1S6-09-X-2	T-1S6-11-X-2
-09	T-1S6-09-X-2	T-1S6-11-X-2	T-1S6-20-X-2
-10	T-1S6-10-X-2	T-1S6-12-X-2	T-1S6-13-X-2
-11	T-1S6-11-X-2	T-1S6-20-X-2	T-1S6-19-X-2
-12	T-1S6-12-X-2	T-1S6-13-X-2	T-1S6-14-X-2
-13	T-1S6-13-X-2	T-1S6-14-X-2	N/A
-21	T-1S6-14-X-2	N/A	N/A
-22	T-1S6-15-X-2	T-1S6-10-X-2	T-1S6-12-X-2
-23	T-1S6-16-X-2	N/A	N/A
-24	T-1S6-17-X-2	N/A	N/A
-27	T-1S6-19-X-2	N/A	N/A
-28	T-1S6-20-X-2	T-1S6-19-X-2	N/A

LENGTH	"L"
-07	.430 [10.92]
-08	.530 [13.46]
-09	.730 [18.54]
-10	.830 [21.08]
-11	.930 [23.62]
-12	1.030 [26.16]
-13	1.230 [31.24]
-14	1.430 [36.32]
-15	.630 [16.00]
-16	.445 [11.30]
-17	.480 [12.19]
-18	.300 [7.62]
-19	1.330 [33.78]
-20	1.130 [28.70]
-21	.335 [8.51]

ROW / OPTION	USE BODY
-S / -S-NA / -S-NE	TSW-50-S
-S-RA / -S-RE	TSW-50-S-RA
-D / -D-NA / -D-NE	RTSW-50-D
-D-RA	TSW-50-D-RA
-T / -T-NA / -T-NE	TSW-50-T
-T-RA	TSW-50-T-RA
-Q	TSW-50-T

TERMINAL SPACE SPEC.

(SEE ASSEMBLY INSTR.)
 -1 = .100[2.54] (FILL EVERY POS)
 -2 = .200[5.08] (FILL E/O POS STARTING W/ 1ST & ENDING W/ LAST POS IN BODY)

BODY LENGTH SPEC.

EXPRESSED IN # OF POS
 -1: 01 THRU -50 (-S, -D, -T)
 "A"= NO OF POS x .100[2.54]
 -2: 02 THRU -25 (-S, -D, -T)
 "A"= (NO OF POS x .200[5.08]) - .100[2.54]

TERMINAL SPECIFICATION

(SEE TABLE 1)

PLATING SPECIFICATION

-G: 10µ" GOLD CONTACT, 3µ" GOLD TAIL
 -T: MATTE TIN CONTACT AND TAIL
 -S: 30µ" SELECTIVE GOLD IN CONTACT AREA, MATTE TIN ON TAIL
 -L: 10µ" SELECTIVE GOLD IN CONTACT AREA, MATTE TIN ON TAIL
 -E: 50µ" HEAVY GOLD ON CONTACT AREA, 3µ" GOLD ON TAIL
 -H: 30µ" HEAVY GOLD CONTACT AREA, 3µ" GOLD ON TAIL
 -F: 3µ" FLASH SELECTIVE GOLD CONTACT, MATTE TIN TAIL
 -STL: 30µ" GOLD SELECTIVE ON CONTACT TIN/LEAD (90/10+/-5%) TAIL
 -TM: MATTE TIN CONTACT AND TAIL
 -SM: 30µ" SELECTIVE GOLD CONTACT MATTE TIN TAIL
 -LM: 10µ" LIGHT SELECTIVE GOLD CONTACT MATTE TIN TAIL
 -FM: 3µ" GOLD FLASH SELECTIVE ON CONTACT MATTE TIN TAIL

OPTION #2

-POLARIZATION SPEC.
 XXX INDICATES POS TO BE OMITTED (SEE FIG 6, SHT 5)

OPTION #1

-BLANK = STRAIGHT
 -RA = RIGHT ANGLE (SEE TABLE 3 & FIG 2, SHT 2) (-05 N/A) (-RA OPTION WITH -LL OPTION EQUALS TO -LA OPTION)
 -RE = EXTENDED RIGHT ANGLE (SEE TABLE 3 & FIG 2, SHT 2) (SINGLE ROW ONLY) (-05, -07, -23 -24 N/A)
 -NA = RA OPTION WITH STRAIGHT OPTION BODY (SEE TABLE 3 & FIG 3, SHT 2) (-NA OPTION WITH -LL OPTION IS VALID)
 -NE = RE OPTION WITH STRAIGHT OPTION BODY (SEE TABLE 3 & FIG 3, SHT 2)
 -LL = LOCKING LEAD (SEE FIG 4, SHT 3 & FIG 5, SHT 4) (N/A WITH -RE OPTION OR SINGLE ROW 1 OR 2 POSITIONS)
 -LA = -RA OPTION WITH -LL OPTION (SEE FIG 4, SHT 3 & FIG 5, SHT 4) (N/A IN SINGLE ROW 1 OR 2 POSITION) (TAILS FROM .090[2.29] TO .310[7.87] ONLY) (N/A IN SINGLE ROW, 1 OR 2 POSITIONS) POST = .530[13.46] MAX

POST HEIGHT

XXXX = "C" (SEE TABLE 4)

ROW SPECIFICATION (SEE TABLE 2)

-S: SINGLE
 -D: DOUBLE
 -T: TRIPLE
 -Q: TRIPLE ROW (FILL OUTER ROWS ONLY)

TABLE 4

FOR -RX OPTION: TAIL = "L" - "C" - "B" -.15 REF
 FOR -NX OPTION: TAIL = "L" - "C" - "B" -.13 REF
 (CALCULATIONS APPLY TO FIRST ROW PIN LENGTHS ONLY)

LEAD STYLE	"C" MAXIMUM STRAIGHT	"C" MAXIMUM W/ RA	"C" MAXIMUM W/ RE
-05	.235 [5.97]	N/A	N/A
-06	.200 [5.08]	N/A	N/A
-07	.330 [8.38]	.130 [3.30]	N/A
-08	.430 [10.92]	.230 [5.84]	.130 [3.30]
-09	.630 [16.00]	.430 [10.92]	.330 [8.38]
-10	.730 [18.54]	.530 [13.46]	.430 [10.92]
-11	.830 [21.08]	.630 [16.00]	.530 [13.46]
-12	.930 [23.62]	.730 [18.54]	.630 [16.00]
-13	1.130 [28.70]	.930 [23.62]	.830 [21.08]
-21	1.330 [33.78]	1.130 [28.70]	1.030 [26.16]
-22	.530 [13.46]	.330 [8.38]	.230 [5.84]
-23	.345 [8.76]	.145 [3.68]	N/A
-24	.380 [9.65]	.180 [4.57]	N/A
-27	1.230 [31.24]	1.030 [26.16]	.930 [23.62]
-28	1.030 [26.16]	.830 [21.08]	.730 [18.54]

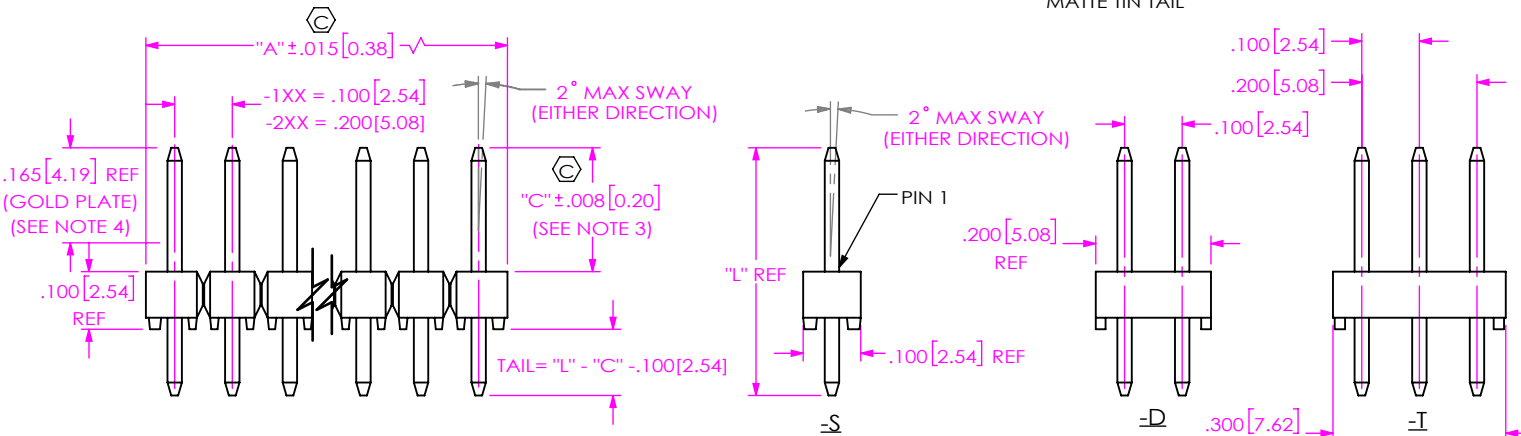

FIG 1
MTSW-XXX-XX-X-X-XXXX SHOWN

- NOTES:
- ⊕ REPRESENTS A CRITICAL DIMENSION.
 - MINIMUM TERMINAL PUSHOUT FORCE: 3 LBS.
 - MAXIMUM HEIGHT VARIATION BETWEEN ANY TWO ROWS SHALL BE .005[0.13] (RA TAIL N/A).
 - ASSEMBLE GOLD PLATE END AS SHOWN.
 - TOW & SWAY SPEC. OF 2° APPLIES TO ALL POSITIONS, POST & TAIL, IN ALL DIRECTIONS.

- STRAIGHT THROUGH HOLE ONLY.
- ORIENTATE PINS TO REDUCE THE NUMBER OF BANDOLIER MARKS IN THE POST AREA. (SEE TABLE 6)
- MAXIMUM CUT FLASH: .020[0.51].
- TABLE 5 IS A REFERENCE FOR INDIVIDUAL PIN LENGTHS AS LISTED ON THE T-1S6 COMPONENT PRINT AND NOT THE TERMINAL SPEC IN TABLE 1 OR IN THE PART CALLOUT.
- MUST USE T-30193-13 (2 1/2" BLADES) TO CUT -T AND -Q PARTS.

UNLESS OTHERWISE SPECIFIED, DIMENSIONS ARE IN INCHES.

TOLERANCES ARE:
 DECIMALS ANGLES
 .XX: ±.01 [0.3] 2°
 .XXX: ±.005 [0.13]
 .XXXX: ±.0020 [0.051]

PROPRIETARY NOTE

THIS DOCUMENT CONTAINS CONFIDENTIAL AND PROPRIETARY INFORMATION AND ALL DESIGN, MANUFACTURING, REPRODUCTION, USE, PATENT RIGHTS AND SALES RIGHTS ARE EXPRESSLY RESERVED BY SAMTEC, INC. THIS DOCUMENT SHALL NOT BE DISCLOSED, IN WHOLE OR PART, TO ANY UNAUTHORIZED PERSON OR ENTITY NOR REPRODUCED, TRANSFERRED OR INCORPORATED IN ANY OTHER PROJECT IN ANY MANNER WITHOUT THE EXPRESS WRITTEN CONSENT OF SAMTEC, INC.

MATERIAL: DO NOT SCALE DRAWING SHEET SCALE: 3:1
BODY: GLASS FILLED POLYESTER, COLOR: BLACK
TERMINAL: PHOSPHOR BRONZE



520 PARK EAST BLVD, NEW ALBANY, IN 47150
 PHONE: 812-944-6733 FAX: 812-948-5047
 e-Mail: info@SAMTEC.com code 55322

DESCRIPTION:
 ASSEMBLY, .025[.64] SQ. POST TERMINAL STRIP
DWG. NO.
 MTSW-XXX-XX-X-X-XXXX-XX-XXX

BY: PURVIS 02/17/1987 SHEET 1 OF 6

TABLE 3	
BODY SPECIFICATION	
-XX	"B"
-RA	.060 [1.52]
-RE	.160 [4.06]

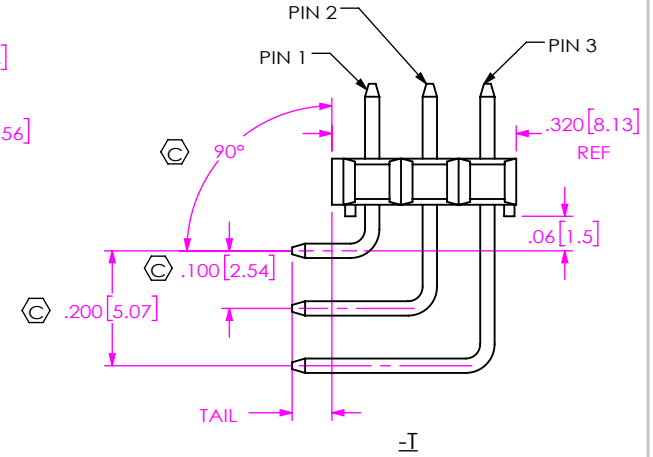
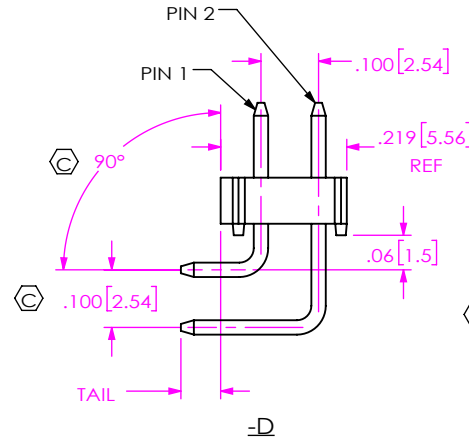
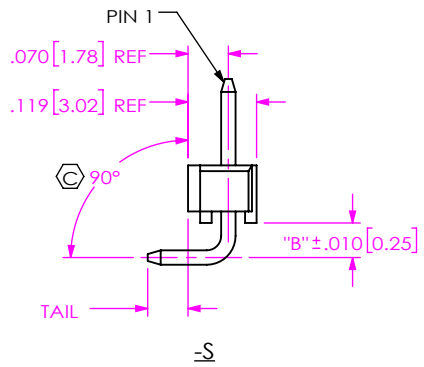
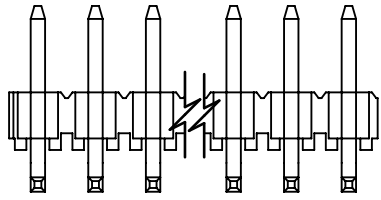

FIG 2
 MTSW-XXX-XX-X-S-XXXX-RX SHOWN
 (DIFFERENT AS SHOWN, OTHERWISE SAME AS FIG 1)

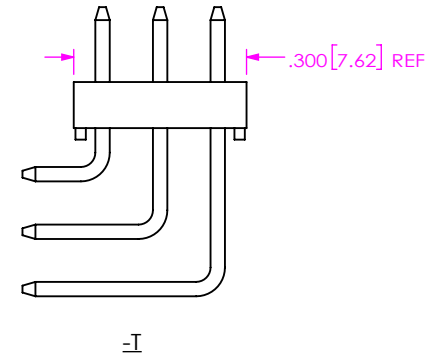
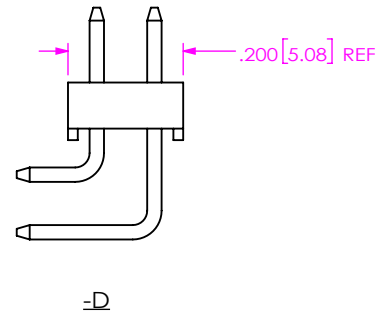
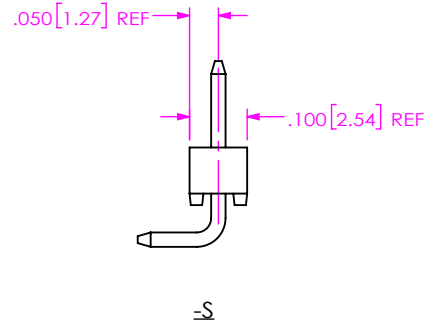
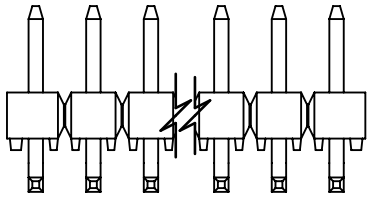

FIG 3
 MTSW-XXX-XX-X-S-XXXX-NX SHOWN
 (DIFFERENT AS SHOWN, OTHERWISE SAME AS FIG 2)

PROPRIETARY NOTE
 THIS DOCUMENT CONTAINS CONFIDENTIAL AND PROPRIETARY INFORMATION AND ALL DESIGN, MANUFACTURING, REPRODUCTION, USE, PATENT RIGHTS AND SALES RIGHTS ARE EXPRESSLY RESERVED BY SAMTEC, INC. THIS DOCUMENT SHALL NOT BE DISCLOSED, IN WHOLE OR PART, TO ANY UNAUTHORIZED PERSON OR ENTITY NOR REPRODUCED, TRANSFERRED OR INCORPORATED IN ANY OTHER PROJECT IN ANY MANNER WITHOUT THE EXPRESS WRITTEN CONSENT OF SAMTEC, INC.



520 PARK EAST BLVD, NEW ALBANY, IN 47150
 PHONE: 812-944-6733 FAX: 812-948-5047
 e-Mail: info@SAMTEC.com code 55322

DO NOT SCALE DRAWING

SHEET SCALE: 1:2

DESCRIPTION:
 ASSEMBLY, .025[.64] SQ. POST TERMINAL STRIP

DWG. NO.
MTSW-XXX-XX-X-X-XXXX-XX-XXX

BY: PURVIS 02/17/1987 SHEET 2 OF 6

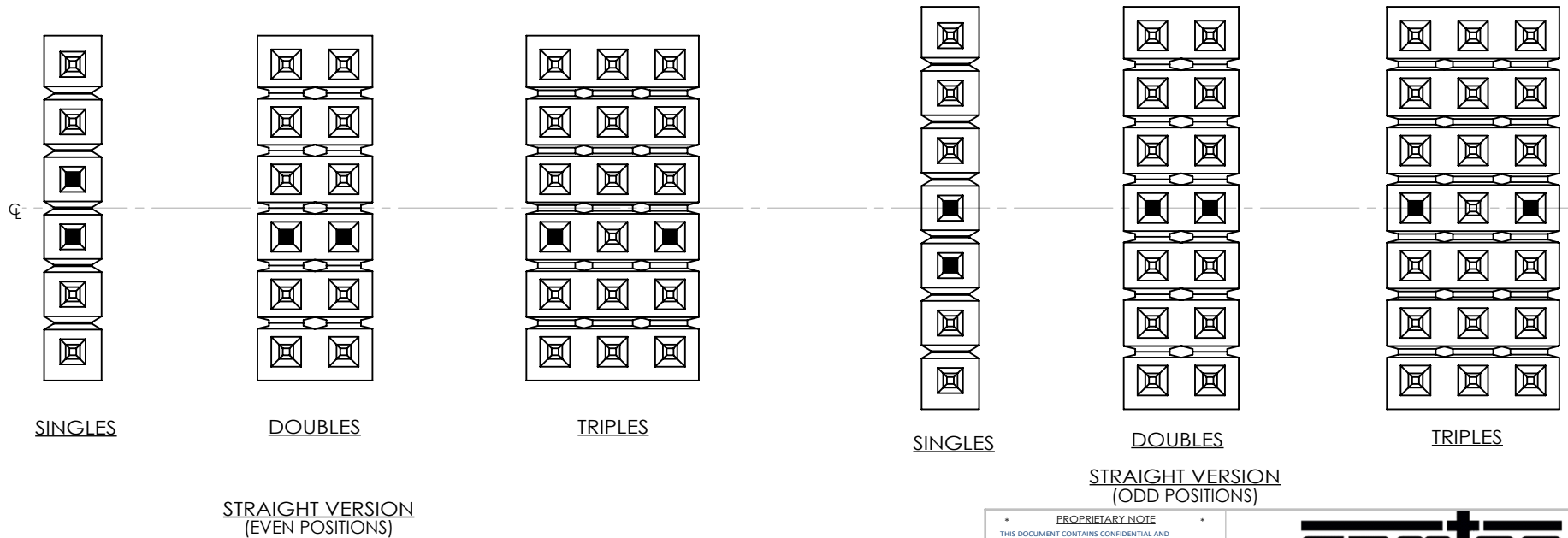
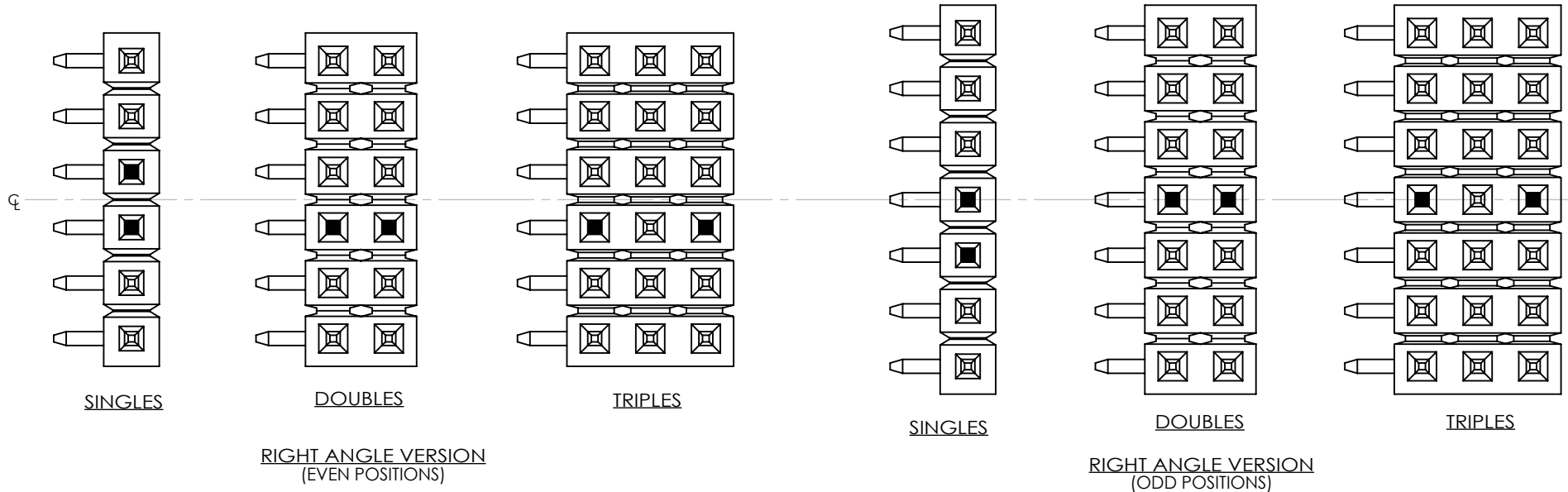

FIG 4
LOCKING LEAD
(STRAIGHT & RA VERSIONS)
■ = CRIMP LOCATION

PROPRIETARY NOTE
THIS DOCUMENT CONTAINS CONFIDENTIAL AND PROPRIETARY INFORMATION AND ALL DESIGN, MANUFACTURING, REPRODUCTION, USE, PATENT RIGHTS AND SALES RIGHTS ARE EXPRESSLY RESERVED BY SAMTEC, INC. THIS DOCUMENT SHALL NOT BE DISCLOSED, IN WHOLE OR PART, TO ANY UNAUTHORIZED PERSON OR ENTITY NOR REPRODUCED, TRANSFERRED OR INCORPORATED IN ANY OTHER PROJECT IN ANY MANNER WITHOUT THE EXPRESS WRITTEN CONSENT OF SAMTEC, INC.

samtec
520 PARK EAST BLVD, NEW ALBANY, IN 47150
PHONE: 812-944-6733 FAX: 812-948-5047
e-Mail: info@SAMTEC.com code 55322

DO NOT SCALE DRAWING
SHEET SCALE: 4:1

DESCRIPTION:
ASSEMBLY, .025[.64] SQ. POST TERMINAL STRIP
DWG. NO.
MTSW-XXX-XX-X-X-XXXX-XX-XXX
BY: PURVIS 02/17/1987 SHEET 3 OF 6

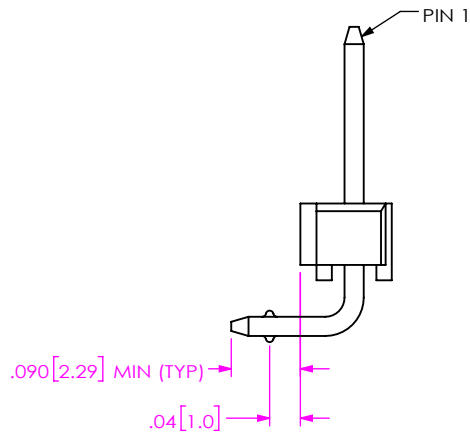

SINGLE -RA/-RE
(SHOWN WITH -LA OPTION)

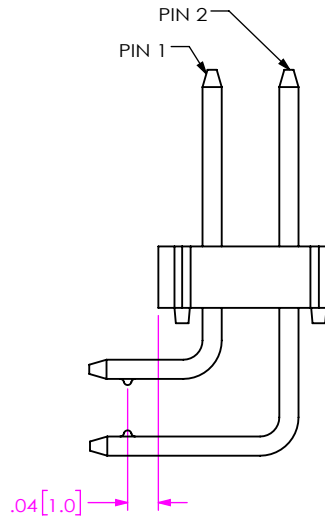

DOUBLE -RA
(SHOWN WITH -LA OPTION)

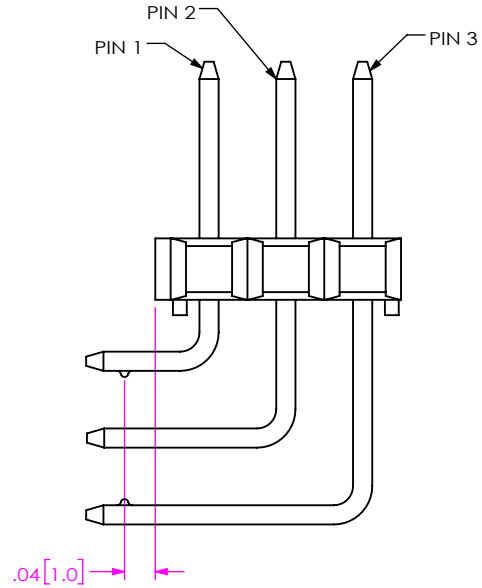

TRIPLE -RA
(SHOWN WITH -LA OPTION)

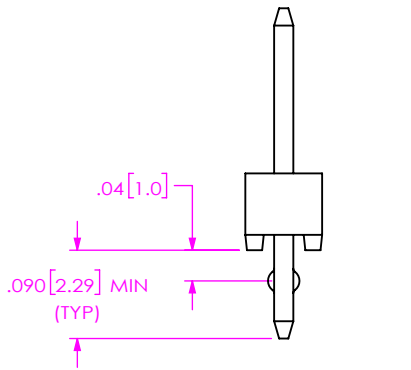

SINGLE
(SHOWN WITH -LL OPTION)

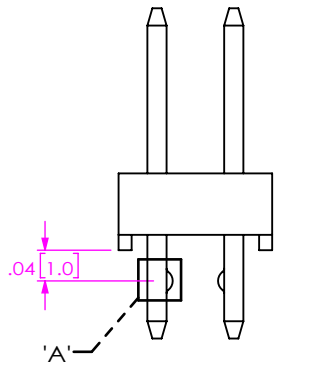

DOUBLE
(SHOWN WITH -LL OPTION)

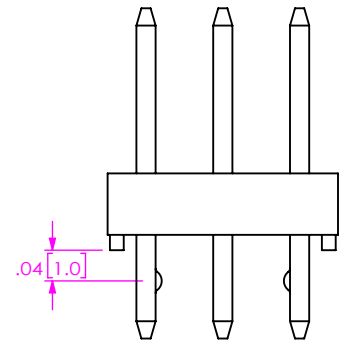

TRIPLE
(SHOWN WITH -LL OPTION)

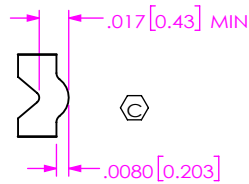
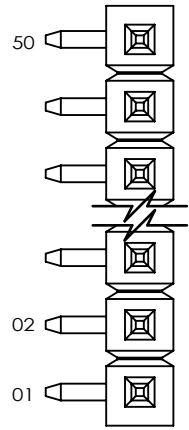

FIG 5

DETAIL 'A'
(CRIMP DETAIL)
(TYP ALL CRIMPS)

<p>PROPRIETARY NOTE</p> <p>THIS DOCUMENT CONTAINS CONFIDENTIAL AND PROPRIETARY INFORMATION AND ALL DESIGN, MANUFACTURING, REPRODUCTION, USE, PATENT RIGHTS AND SALES RIGHTS ARE EXPRESSLY RESERVED BY SAMTEC, INC. THIS DOCUMENT SHALL NOT BE DISCLOSED, IN WHOLE OR PART, TO ANY UNAUTHORIZED PERSON OR ENTITY NOR REPRODUCED, TRANSFERRED OR INCORPORATED IN ANY OTHER PROJECT IN ANY MANNER WITHOUT THE EXPRESS WRITTEN CONSENT OF SAMTEC, INC.</p>	<p>samtec</p> <p>520 PARK EAST BLVD, NEW ALBANY, IN 47150 PHONE: 812-944-6733 FAX: 812-948-5047 e-Mail: info@SAMTEC.com code 55322</p>	
	<p>DO NOT SCALE DRAWING</p> <p>SHEET SCALE: 4:1</p>	<p>DESCRIPTION: ASSEMBLY, .025[.64] SQ. POST TERMINAL STRIP DWG. NO. MTSW-XXX-XX-X-X-XXXX-XX-XXX BY: PURVIS 02/17/1987 SHEET 4 OF 6</p>



-S: SINGLES

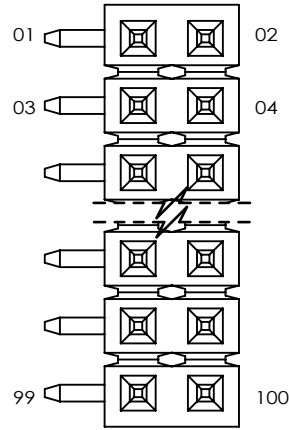

-D: DOUBLES

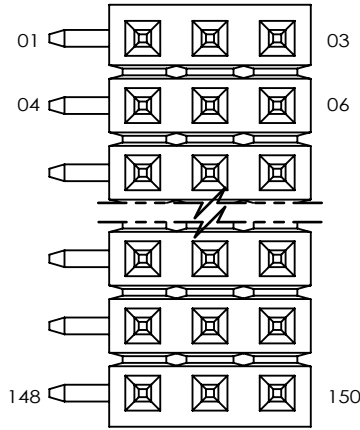

-T: TRIPLES

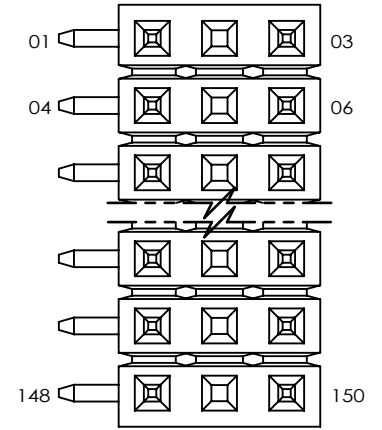

-Q: TRIPLES
(FILL OUTER ROWS ONLY)

-1 = .100 TERMINAL SPACING

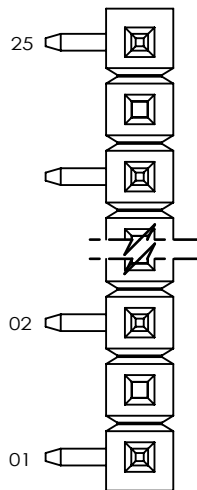

-S: SINGLES

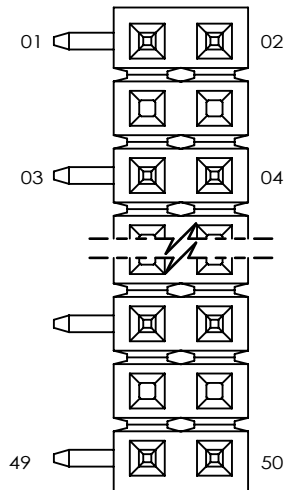

-D: DOUBLES

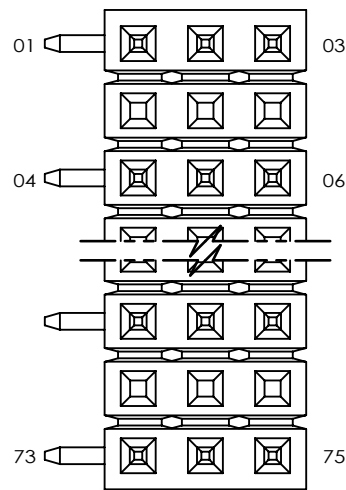

-T: TRIPLES

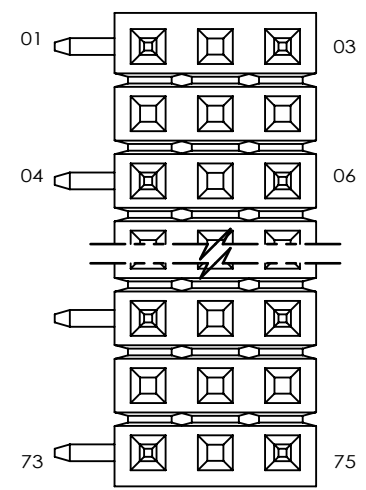

-Q: TRIPLES
(FILL OUTER ROWS ONLY)

-2 = .200 TERMINAL SPACING

FIG 6
POLARIZATION
(STRAIGHT & RA VERSIONS)

PROPRIETARY NOTE

THIS DOCUMENT CONTAINS CONFIDENTIAL AND PROPRIETARY INFORMATION AND ALL DESIGN, MANUFACTURING, REPRODUCTION, USE, PATENT RIGHTS AND SALES RIGHTS ARE EXPRESSLY RESERVED BY SAMTEC, INC. THIS DOCUMENT SHALL NOT BE DISCLOSED, IN WHOLE OR PART, TO ANY UNAUTHORIZED PERSON OR ENTITY NOR REPRODUCED, TRANSFERRED OR INCORPORATED IN ANY OTHER PROJECT IN ANY MANNER WITHOUT THE EXPRESS WRITTEN CONSENT OF SAMTEC, INC.

DO NOT SCALE DRAWING

SHEET SCALE: 4:1



520 PARK EAST BLVD, NEW ALBANY, IN 47150
PHONE: 812-944-6733 FAX: 812-948-5047
e-Mail: info@SAMTEC.com code 55322

DESCRIPTION:
ASSEMBLY, .025[.64] SQ. POST TERMINAL STRIP

DWG. NO.
MTSW-XXX-XX-X-X-XXXX-XX-XXX

BY: PURVIS 02/17/1987 SHEET 5 OF 6

TABLE 6			
LEAD STYLE	NUMBER OF BAND MARKS ALLOWED IN POST AREA		
	PIN #1	PIN #2	PIN #3
*-05	1	N/A	N/A
-06	1	N/A	N/A
-07	1	1	1
-07-RA	0	0	0
-08	2	2	2
-08-RA	0	0	0
-08-RE	0	0	0
*-09	2	2	2
*-09-RA	1	0	0
*-09-RE	0	0	0
*-10	2	2	2
*-10-RA	1	0	0
*-10-RE	0	0	0
*-11	2	2	2
*-11-RA	1	0	0
*-11-RE	0	0	0
*-12	2	2	2
*-12-RA	1	0	0
*-12-RE	0	0	0
*-13	2	2	N/A
*-13-RA	1	0	N/A
*-13-RE	0	0	N/A
*-21	2	N/A	N/A
*-21-RA	1	N/A	N/A
*-21-RE	0	N/A	N/A
-22	2	2	2
*-22-RA	1	0	0
*-22-RE	0	0	0
-23	2	N/A	N/A
-23-RA	0	N/A	N/A
-24	2	N/A	N/A
-24-RA	0	N/A	N/A
*-27	2	N/A	N/A
*-27-RA	1	N/A	N/A
*-27-RE	0	N/A	N/A
*-28	2	2	N/A
*-28-RA	1	0	N/A
*-28-RE	0	0	N/A

* PINS TO BE FLIPPED OPPOSITE OF SELECTIVE PLATING BEFORE BEING INSERTED

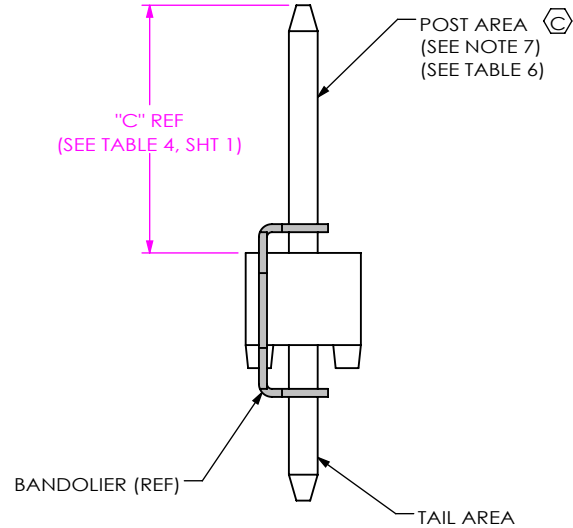

IN PROCESS 1
-T PLATING ONLY

PROPRIETARY NOTE
 THIS DOCUMENT CONTAINS CONFIDENTIAL AND PROPRIETARY INFORMATION AND ALL DESIGN, MANUFACTURING, REPRODUCTION, USE, PATENT RIGHTS AND SALES RIGHTS ARE EXPRESSLY RESERVED BY SAMTEC, INC. THIS DOCUMENT SHALL NOT BE DISCLOSED, IN WHOLE OR PART, TO ANY UNAUTHORIZED PERSON OR ENTITY NOR REPRODUCED, TRANSFERRED OR INCORPORATED IN ANY OTHER PROJECT IN ANY MANNER WITHOUT THE EXPRESS WRITTEN CONSENT OF SAMTEC, INC.



520 PARK EAST BLVD, NEW ALBANY, IN 47150
 PHONE: 812-944-6733 FAX: 812-948-5047
 e-Mail: info@SAMTEC.com code 55322

DO NOT SCALE DRAWING

SHEET SCALE: 4:1

DESCRIPTION:
 ASSEMBLY, .025[.64] SQ. POST TERMINAL STRIP

DWG. NO.
MTSW-XXX-XX-X-X-XXXX-XX-XXX

BY: PURVIS 02/17/1987 SHEET 6 OF 6