

DO NOT SCALE FROM THIS PRINT

DESIGNED & DIMENSIONED IN INCHES[MILLIMETERS]

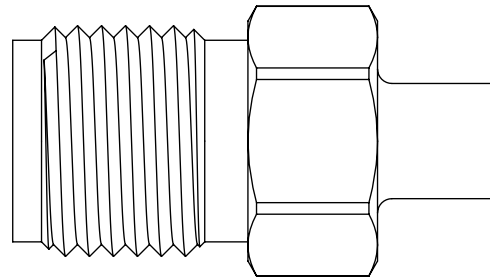
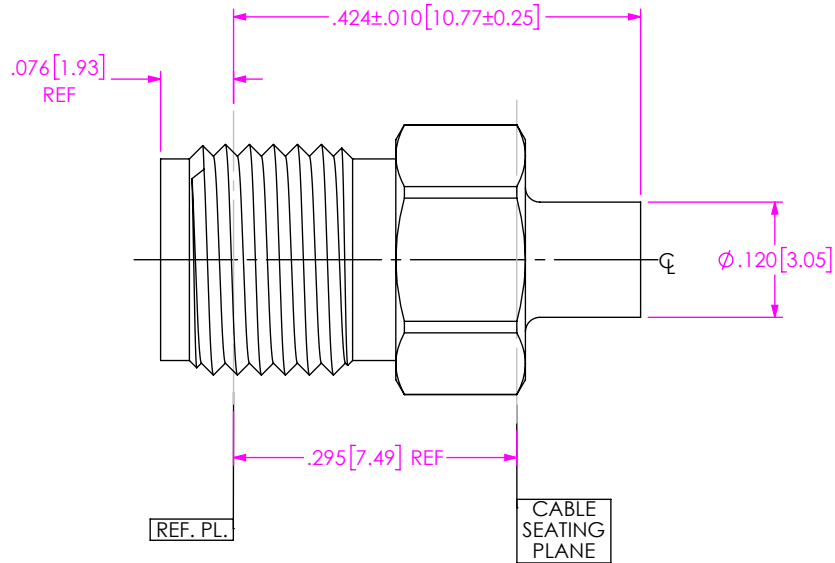

EXPLODED VIEW
NOT TO SCALE
(FOR CLARITY ONLY)

PRF01-J-C-EE-405-SD

SERIES
-01: SMA

GENDER
-J: JACK

TYPE
-C: CABLE

TERMINATION
-D: DIRECT SOLDER

ORIENTATION
-S: STRAIGHT

CABLE TYPE
-405: RG-405 SEMI-RIGID

FINISH
-EE: 50µ" EXTRA HEAVY GOLD CENTER CONTACT,
50µ" EXTRA HEAVY GOLD OUTER CONTACT

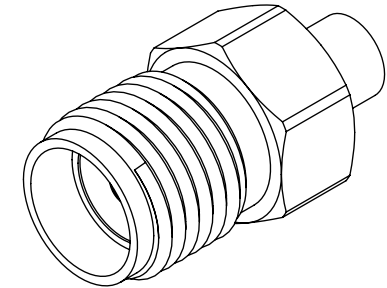

NOTES:

- MATERIAL:**
BODY, CONTACT: BERYLLIUM COPPER
INSULATORS: PTFE.
- FINISH:**
BODY, CONTACT: 50µ" MIN. GOLD OVER 50µ" MIN. NICKEL PLATE.
- PCI P/N: 3776.

UNLESS OTHERWISE SPECIFIED,
DIMENSIONS ARE IN INCHES.
TOLERANCES ARE:
DECIMALS ANGLES
.XX: ±.01 [0.3] 1°
.XXX: ±.005 [0.13]
.XXXX: ±.0005 [0.013]

PROPRIETARY NOTE
THIS DOCUMENT CONTAINS CONFIDENTIAL AND PROPRIETARY INFORMATION AND ALL DESIGN, MANUFACTURING, REPRODUCTION, USE, PATENT RIGHTS AND SALES RIGHTS ARE EXPRESSLY RESERVED BY SAMTEC, INC. THIS DOCUMENT SHALL NOT BE DISCLOSED, IN WHOLE OR PART, TO ANY UNAUTHORIZED PERSON OR ENTITY NOR REPRODUCED, TRANSFERRED OR INCORPORATED IN ANY OTHER PROJECT IN ANY MANNER WITHOUT THE EXPRESS WRITTEN CONSENT OF SAMTEC, INC.

F:\DWG\MISC\MKTG\PRF01-J-C-EE-405-SD-MKT.SLDDRW



520 PARK EAST BLVD, NEW ALBANY, IN 47150
PHONE: 812-944-6733 FAX: 812-948-5047
e-Mail: info@SAMTEC.com code 55322

DO NOT SCALE DRAWING

SHEET SCALE: 5:1

DESCRIPTION: SMA JACK DIRECT SOLDER FOR RG-405 SEMI-RIGID CABLE

DWG. NO. PRF01-J-C-EE-405-SD

BY: CANDY W 4/2/2019 SHEET 1 OF 2

CABLE APPLICATION VIEWS

- 1A. PRE-TIN CABLE OUTER JACKET TO DIMENSION SHOWN.
- 1B. TRIM CABLE JACKET & DIELECTRIC, THEN POINT CENTER CONDUCTOR AS SHOWN (DO NOT NICK CENTER CONDUCTOR).

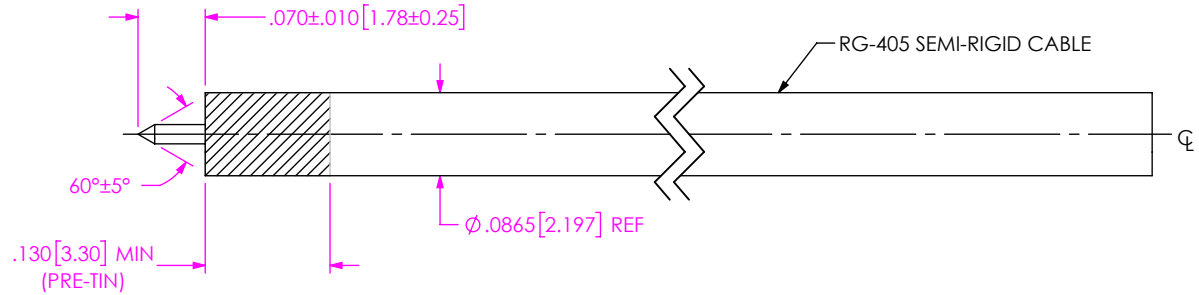

IN-PROCESS VIEW 1

- 2A. INSERT CABLE INTO CONNECTOR UNTIL CENTER CONDUCTOR PLUGS IN AND CABLE SEATS IN CONNECTOR BORE.
- 2B. SOLDER CABLE JACKET TO BODY WHERE SHOWN APPLYING HEAT TO EXTENDED BODY TAIL.

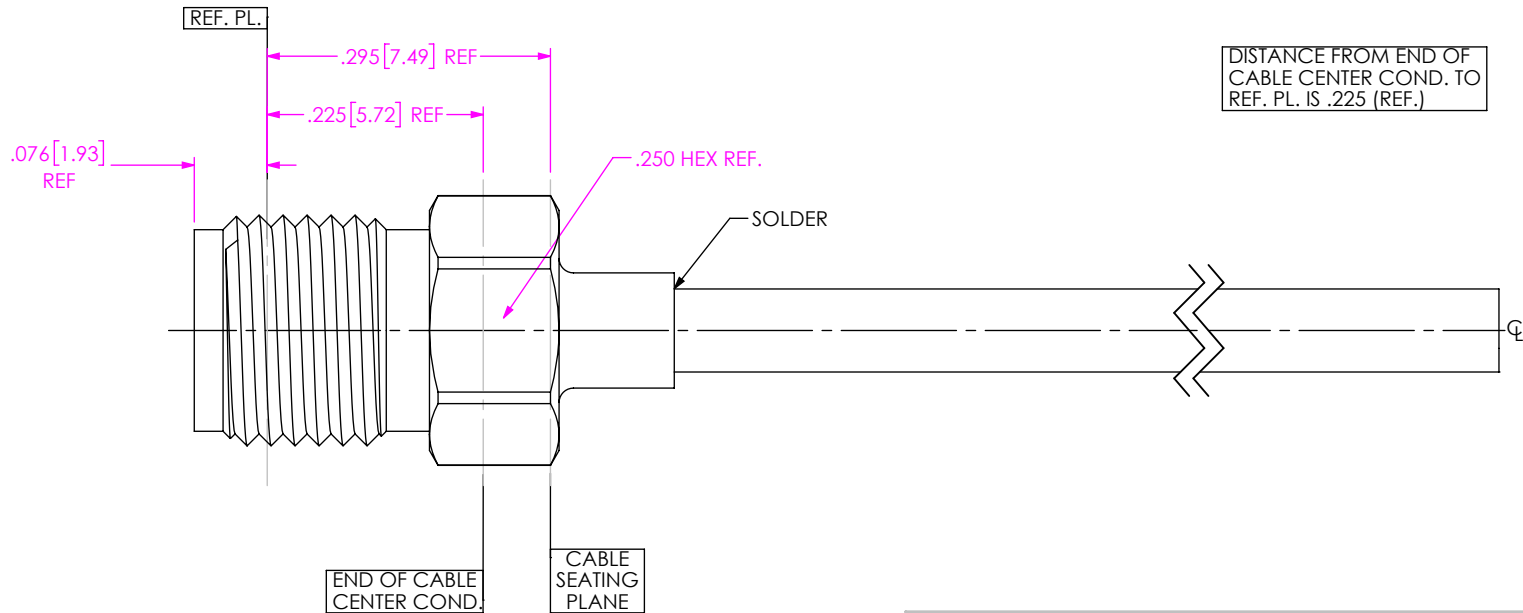

IN-PROCESS VIEW 2

PROPRIETARY NOTE
 THIS DOCUMENT CONTAINS CONFIDENTIAL AND PROPRIETARY INFORMATION AND ALL DESIGN, MANUFACTURING, REPRODUCTION, USE, PATENT RIGHTS AND SALES RIGHTS ARE EXPRESSLY RESERVED BY SAMTEC, INC. THIS DOCUMENT SHALL NOT BE DISCLOSED, IN WHOLE OR PART, TO ANY UNAUTHORIZED PERSON OR ENTITY NOR REPRODUCED, TRANSFERRED OR INCORPORATED IN ANY OTHER PROJECT IN ANY MANNER WITHOUT THE EXPRESS WRITTEN CONSENT OF SAMTEC, INC.



520 PARK EAST BLVD, NEW ALBANY, IN 47150
 PHONE: 812-944-6733 FAX: 812-948-5047
 e-Mail info@SAMTEC.com code 55322

DO NOT SCALE DRAWING
 SHEET SCALE: 5:1

| | |
|--------------|--|
| DESCRIPTION: | SMA JACK DIRECT SOLDER FOR RG-405 SEMI-RIGID CABLE |
| DWG. NO. | PRF01-J-C-EE-405-SD |
| BY: | CANDY W 4/2/2019 |
| SHEET | 2 OF 2 |