

DO NOT SCALE FROM THIS PRINT

DESIGNED & DIMENSIONED IN INCHES[MILLIMETERS]

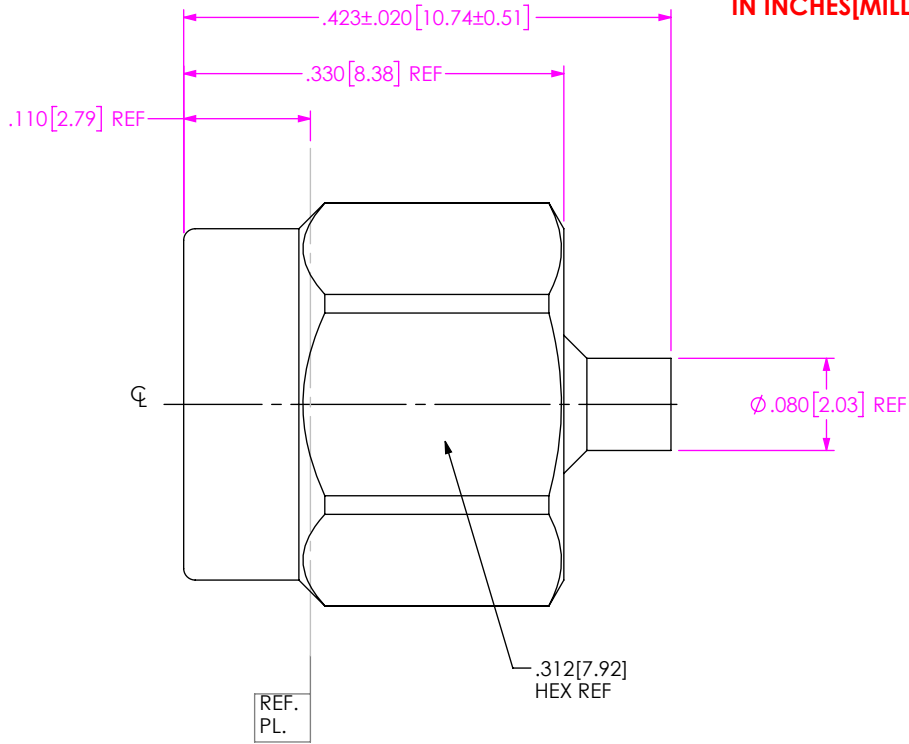

**PRF01-P-C-EE-047B-SD**

**INTERFACE**  
-01: SMA

**GENDER**  
-P: PLUG

**COMPONENT**  
-C: CABLE

**TERMINATION**  
-D: DIRECT SOLDER

**ORIENTATION**  
-S: STRAIGHT

**CABLE TYPE**  
-047B: TEMP FLEX 1001935047

**FINISH**  
-EE: 50µ" EXTRA HEAVY GOLD CENTER CONTACT, 50µ" EXTRA HEAVY GOLD OUTER CONTACT

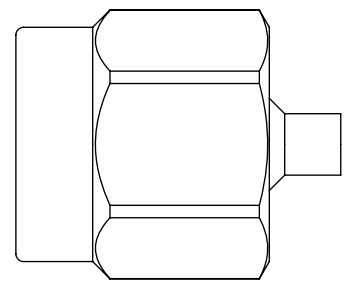
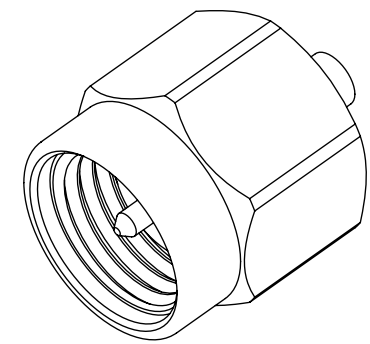

EXPLODED VIEW  
NOT TO SCALE  
(FOR CLARITY ONLY)

NOTES:

- MATERIAL:**  
COUPLING NUT: STAINLESS STEEL  
BODY, CONTACT, LOCK RING: BERYLLIUM COPPER  
INSULATORS: PTFE  
GASKET: SILICONE RUBBER
- FINISH:**  
COUPLING NUT: PASSIVATED  
BODY, CONTACT: 50µ" MIN. GOLD OVER 50µ" MIN. NICKEL PLATE
- PCI P/N: 4130

UNLESS OTHERWISE SPECIFIED, DIMENSIONS ARE IN INCHES. TOLERANCES ARE: DECIMALS                      ANGLES .XX: ±.01 [0.3]                      1° .XXX: ±.005 [0.13] .XXXX: ±.0005 [0.013]	* <b>PROPRIETARY NOTE</b> * THIS DOCUMENT CONTAINS CONFIDENTIAL AND PROPRIETARY INFORMATION AND ALL DESIGN, MANUFACTURING, REPRODUCTION, USE, PATENT RIGHTS AND SALES RIGHTS ARE EXPRESSLY RESERVED BY SAMTEC, INC. THIS DOCUMENT SHALL NOT BE DISCLOSED, IN WHOLE OR PART, TO ANY UNAUTHORIZED PERSON OR ENTITY NOR REPRODUCED, TRANSFERRED OR INCORPORATED IN ANY OTHER PROJECT IN ANY MANNER WITHOUT THE EXPRESS WRITTEN CONSENT OF SAMTEC, INC.	 520 PARK EAST BLVD, NEW ALBANY, IN 47150 PHONE: 812-944-6733    FAX: 812-948-5047 e-Mail: info@SAMTEC.com    code 55322	
		DO NOT SCALE DRAWING                      SHEET SCALE: 6:1	DESCRIPTION: SMA PLUG, DIRECT SOLDER FOR LAB-FLEX 065T CABLE
		DWG. NO. <b>PRF01-P-C-EE-047B-SD</b>	
		BY: WILLY Y                      4/12/2022	SHEET 1 OF 2

# CABLE APPLICATION VIEWS

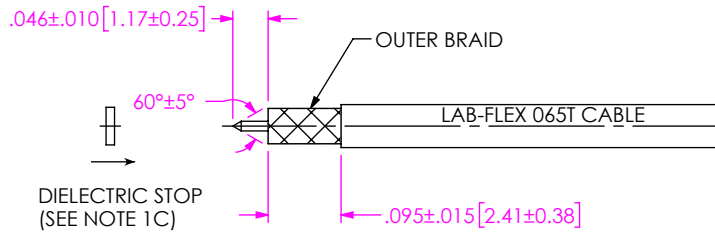

- 1A. TRIM CABLE TO EXPOSE OUTER BRAID AND CENTER CONDUCTOR AS SHOWN.
- 1B. POINT CENTER CONDUCTOR AS INDICATED.
- 1C. SLIDE DIELECTRIC STOP ONTO CENTER CONDUCTOR AGAINST OUTER BRAID.

IN-PROCESS VIEW 1

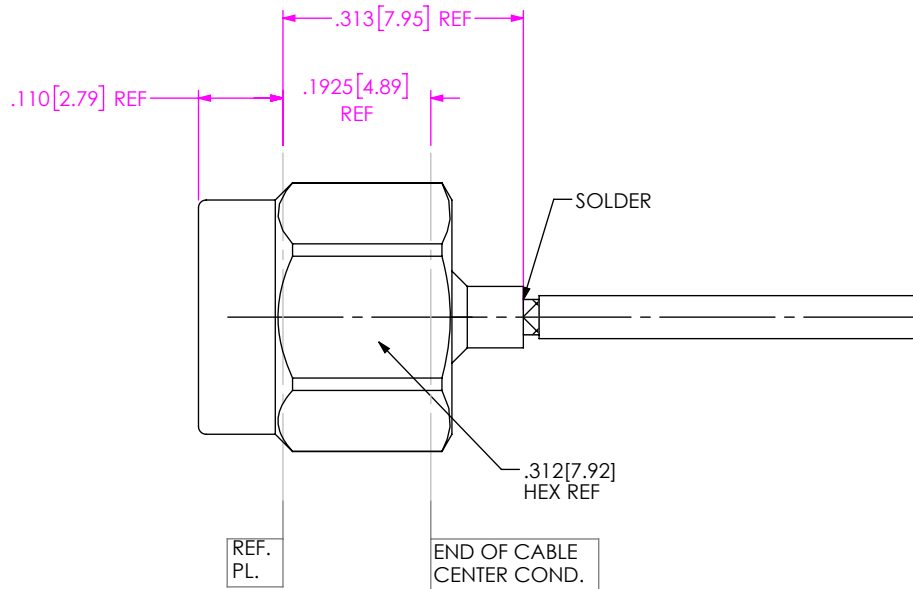

- 2A. INSERT CABLE INTO CONNECTOR UNTIL CENTER CONDUCTOR PLUGS IN AND DIEL. STOP SEAT AGAINST CONTACT.
- 2B. SOLDER CABLE BRAIDS TO BODY WHERE SHOWN APPLYING HEAT TO EXTENDED BODY TAIL.

IN-PROCESS VIEW 2

<p>DO NOT SCALE DRAWING</p> <p>SHEET SCALE: 6:1</p>	<p><b>PROPRIETARY NOTE</b></p> <p>THIS DOCUMENT CONTAINS CONFIDENTIAL AND PROPRIETARY INFORMATION AND ALL DESIGN, MANUFACTURING, REPRODUCTION, USE, PATENT RIGHTS AND SALES RIGHTS ARE EXPRESSLY RESERVED BY SAMTEC, INC. THIS DOCUMENT SHALL NOT BE DISCLOSED, IN WHOLE OR PART, TO ANY UNAUTHORIZED PERSON OR ENTITY NOR REPRODUCED, TRANSFERRED OR INCORPORATED IN ANY OTHER PROJECT IN ANY MANNER WITHOUT THE EXPRESS WRITTEN CONSENT OF SAMTEC, INC.</p>	<p><b>samtec</b></p> <p>520 PARK EAST BLVD, NEW ALBANY, IN 47150                  PHONE: 812-944-6733 FAX: 812-948-5047                  e-Mail info@SAMTEC.com code 55322</p>
	<p>DESCRIPTION: SMA PLUG, DIRECT SOLDER FOR LAB-FLEX 065T CABLE</p>	
	<p>DWG. NO. PRF01-P-C-EE-047B-SD</p>	
<p>BY: WILLY Y 4/12/2022</p>		<p>SHEET 2 OF 2</p>