

DESIGNED & DIMENSIONED
IN INCHES[MILLIMETERS]

PRF01-P-C-EP-141A-SS

DO NOT
SCALE FROM
THIS PRINT

SERIES
-01: SMA

GENDER
-P: PLUG

TYPE
-C: CABLE

TERMINATION
-S: SOLDER CLAMP

ORIENTATION
-S: STRAIGHT

CABLE TYPE
-141A: HARBOUR SS402

FINISH
-EP: 50µ" EXTRA HEAVY GOLD
CENTER CONTACT, PASSIVATED
OUTER CONTACT

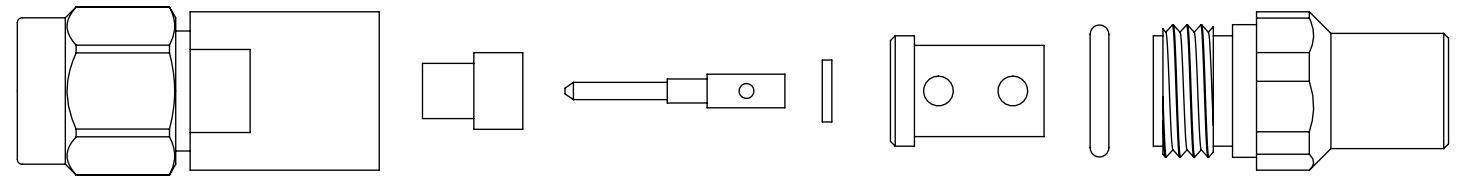
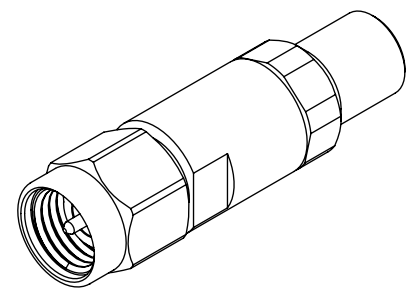
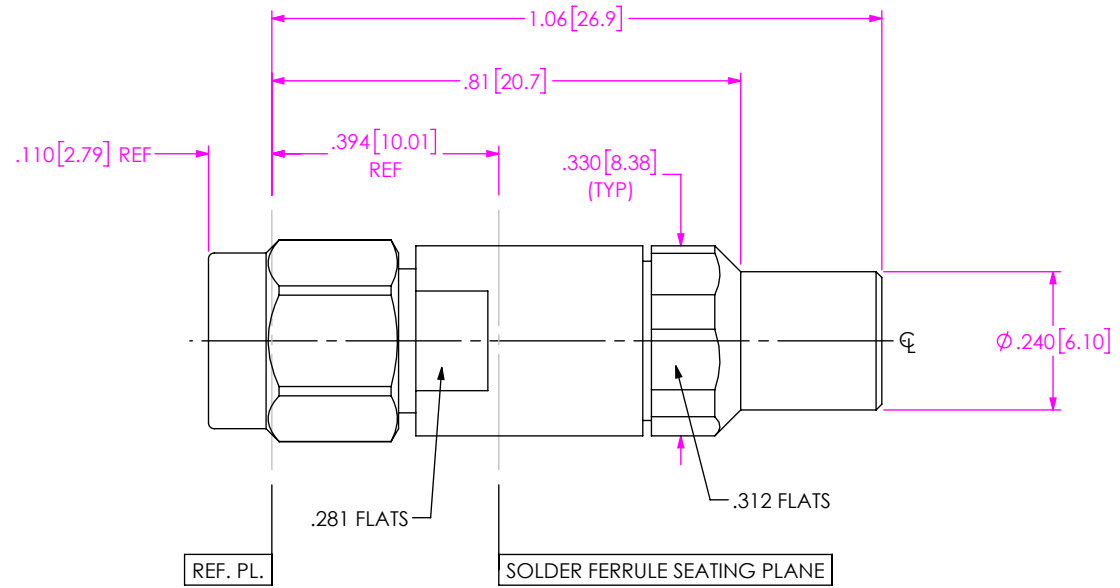

EXPLODED VIEW
NOT TO SCALE
(FOR CLARITY ONLY)

NOTES:

1. MATERIAL:
 BODY, CLAMP NUT, COUPLING NUT: STAINLESS STEEL
 CONTACT, LOCK RING: BERYLLIUM COPPER
 SOLDER FERRULE: BRASS ALLOY
 BEAD: PCTFE
 INSULATOR: PTFE
 GASKET, O-RING: SILICONE RUBBER
2. FINISH:
 BODY, CLAMP NUT, COUPLING NUT: PASSIVATED
 CONTACT, SOLDER FERRULE: 50µ" MIN. GOLD OVER 50µ" MIN. NICKEL PLATE
3. PCI P/N: 3384

F:\DWG\MISC\MKTG\PRF01-P-C-EP-141A-SS-MKT.SLDDRW

| | | |
|---|---|---|
| UNLESS OTHERWISE SPECIFIED, DIMENSIONS ARE IN INCHES. TOLERANCES ARE: DECIMALS ANGLES .XX: ±.01 [0.3] 1° .XXX: ±.005 [0.13] .XXXX: ±.0005 [0.013] | * PROPRIETARY NOTE * THIS DOCUMENT CONTAINS CONFIDENTIAL AND PROPRIETARY INFORMATION AND ALL DESIGN, MANUFACTURING, REPRODUCTION, USE, PATENT RIGHTS AND SALES RIGHTS ARE EXPRESSLY RESERVED BY SAMTEC, INC. THIS DOCUMENT SHALL NOT BE DISCLOSED, IN WHOLE OR PART, TO ANY UNAUTHORIZED PERSON OR ENTITY NOR REPRODUCED, TRANSFERRED OR INCORPORATED IN ANY OTHER PROJECT IN ANY MANNER WITHOUT THE EXPRESS WRITTEN CONSENT OF SAMTEC, INC. |  |
| | | 520 PARK EAST BLVD., NEW ALBANY, IN 47150 PHONE: 812-944-6733 FAX: 812-948-5047 e-Mail info@SAMTEC.com code 55322 |
| | | DESCRIPTION: SMA PLUG, SOLDER CLAMP FOR HARBOUR SS402 CABLE DWG. NO. PRF01-P-C-EP-141A-SS BY: SAMUEL C 04/16/2019 SHEET 1 OF 2 |

CABLE APPLICATION VIEWS

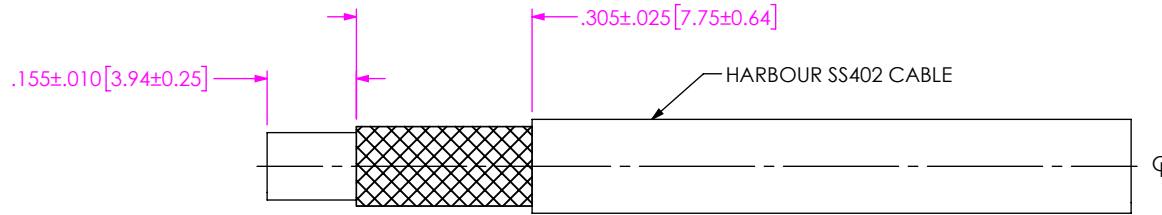

1. TRIM CABLE AS SHOWN.

IN-PROCESS VIEW 1

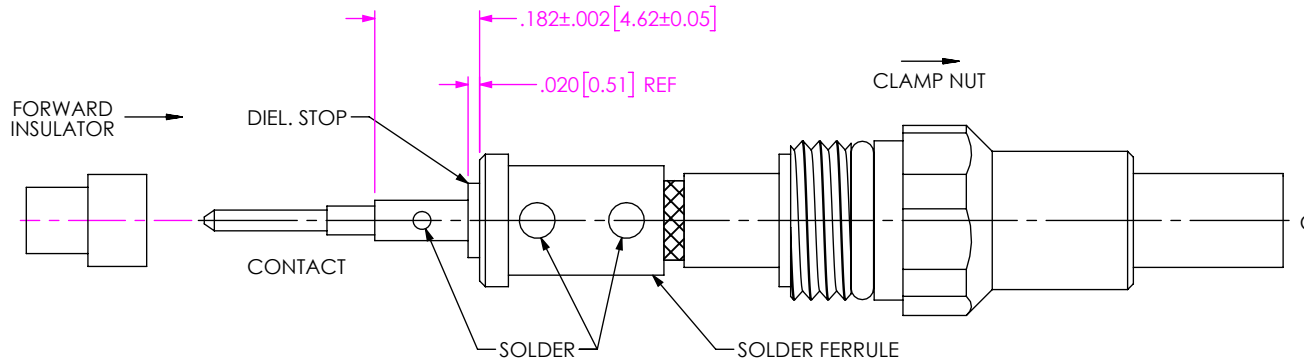

- 2A. SLIDE CLAMP NUT OVER CABLE AS SHOWN.
- 2B. INSERT CABLE INTO SOLDER FERRULE AS SHOWN THEN SOLDER BRAIDS TO FERRULE WHERE INDICATED.
- 2C. TRIM EXPOSED CABLE DIELECTRIC FLUSH WITH SOLDER FERRULE FACE.
- 2D. SLIDE DIELECTRIC STOP OVER CABLE CENTER CONDUCTOR AGAINST FERRULE FACE AND SOLDER CONTACT FLUSH AGAINST STOP TO DIMENSION SHOWN.
- 2E. SLIDE FORWARD INSULATOR ONTO CONTACT.

IN-PROCESS VIEW 2

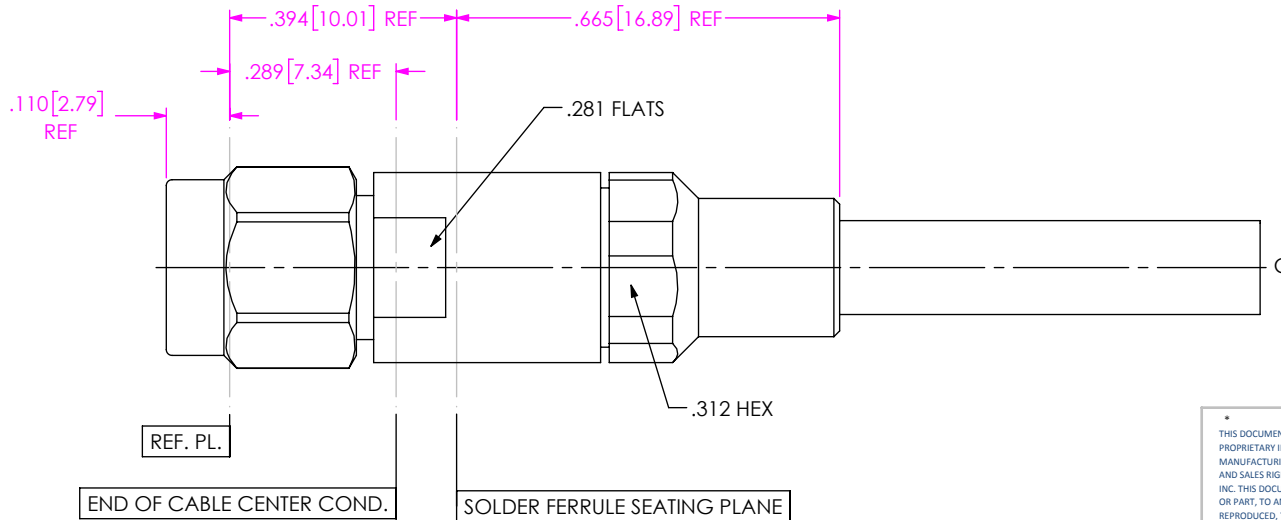

3A. INSERT CABLE/CONTACT SUB-ASSEMBLY INTO CONNECTOR UNTIL SEATED AND TIGHTEN CLAMP NUT TO 25-35 IN.-LBS.

DISTANCE FROM END OF CABLE CENTER CONDUCTOR TO REF PLANE IS .289 REF

IN-PROCESS VIEW 3

PROPRIETARY NOTE
 THIS DOCUMENT CONTAINS CONFIDENTIAL AND PROPRIETARY INFORMATION AND ALL DESIGN, MANUFACTURING, REPRODUCTION, USE, PATENT RIGHTS AND SALES RIGHTS ARE EXPRESSLY RESERVED BY SAMTEC, INC. THIS DOCUMENT SHALL NOT BE DISCLOSED, IN WHOLE OR PART, TO ANY UNAUTHORIZED PERSON OR ENTITY NOR REPRODUCED, TRANSFERRED OR INCORPORATED IN ANY OTHER PROJECT IN ANY MANNER WITHOUT THE EXPRESS WRITTEN CONSENT OF SAMTEC, INC.



520 PARK EAST BLVD, NEW ALBANY, IN 47150
 PHONE: 812-944-6733 FAX: 812-948-5047
 e-Mail info@SAMTEC.com code 55322

DO NOT SCALE DRAWING

SHEET SCALE: 3:1

DESCRIPTION: SMA PLUG, SOLDER CLAMP FOR HARBOUR SS402 CABLE

DWG. NO. PRF01-P-C-EP-141A-SS

BY: SAMUEL C 04/16/2019 SHEET 2 OF 2