

DO NOT SCALE FROM THIS PRINT

DESIGNED & DIMENSIONED IN INCHES[MILLIMETERS]

PRF01-P-C-EP-142-RS-1

SERIES
-01: SMA

GENDER
-P: PLUG

TYPE
-C: CABLE

FINISH
-EP: 50µ" EXTRA HEAVY GOLD CENTER CONTACT, PASSIVATED OUTER CONTACT

OPTION
-1

TERMINATION
-S: SOLDER CLAMP

ORIENTATION
-R: RIGHT ANGLE

CABLE TYPE
-142: HARBOUR LL142

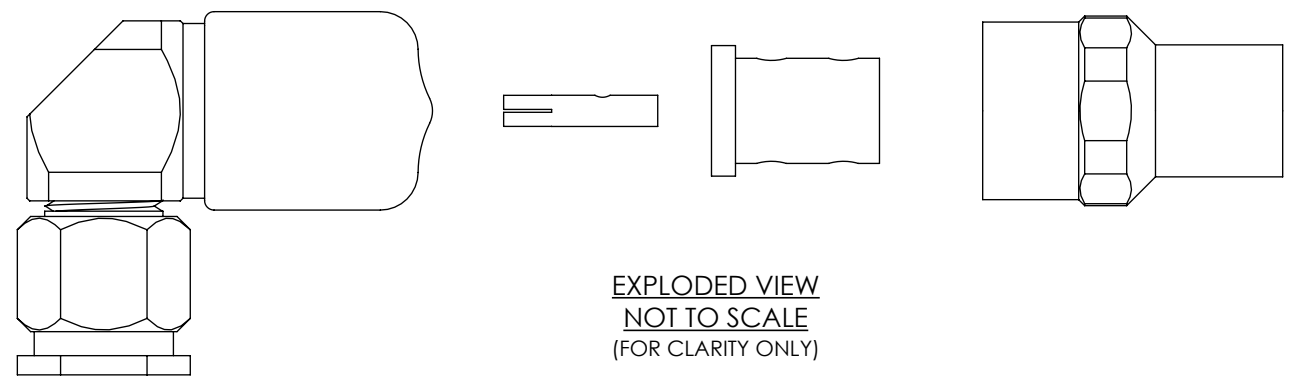
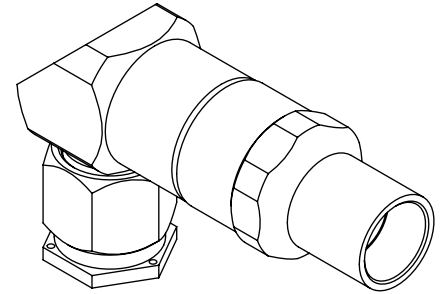
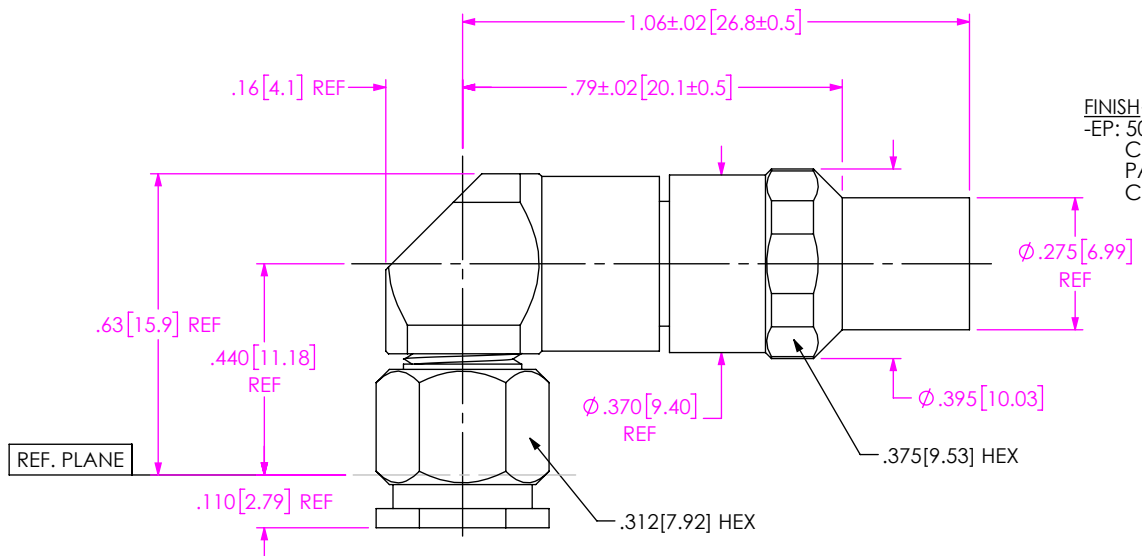

EXPLODED VIEW
NOT TO SCALE
(FOR CLARITY ONLY)

NOTES:

- MATERIAL:**
BODIES, COUPLING NUT, CLAMP NUT: STAINLESS STEEL
CONTACTS, LOCK RING: BERYLLIUM COPPER
SOLDER FERRULE: BRASS ALLOY
INSULATORS: PTFE
GASKET: SILICONE RUBBER
- FINISH:**
BODIES, COUPLING NUT, CLAMP NUT: PASSIVATED
CONTACTS, SOLDER FERRULE: 50µ" MIN. GOLD OVER 50µ" MIN. NICKEL PLATE
- PCI P/N: 3544.

F:\DWG\MISC\MKTG\PRF01-P-C-EP-142-RS-1-MKT.SLDDRW

UNLESS OTHERWISE SPECIFIED, DIMENSIONS ARE IN INCHES. TOLERANCES ARE: DECIMALS ANGLES .XX: ±.01 [0.3] 1° .XXX: ±.005 [0.13] .XXXX: ±.0005 [0.013]	* PROPRIETARY NOTE * THIS DOCUMENT CONTAINS CONFIDENTIAL AND PROPRIETARY INFORMATION AND ALL DESIGN, MANUFACTURING, REPRODUCTION, USE, PATENT RIGHTS AND SALES RIGHTS ARE EXPRESSLY RESERVED BY SAMTEC, INC. THIS DOCUMENT SHALL NOT BE DISCLOSED, IN WHOLE OR PART, TO ANY UNAUTHORIZED PERSON OR ENTITY NOR REPRODUCED, TRANSFERRED OR INCORPORATED IN ANY OTHER PROJECT IN ANY MANNER WITHOUT THE EXPRESS WRITTEN CONSENT OF SAMTEC, INC.	 520 PARK EAST BLVD, NEW ALBANY, IN 47150 PHONE: 812-944-6733 FAX: 812-948-5047 e-Mail info@SAMTEC.com code 55322
		DESCRIPTION: SMA RT. ANGLE PLUG, SOLDER CLAMP FOR HARBOUR LL142 CABLE, L/W HOLES
		DWG. NO. PRF01-P-C-EP-142-RS-1 BY: ETHAN C 05/07/2021 SHEET 1 OF 2

DO NOT SCALE DRAWING SHEET SCALE: 2.5:1

CABLE APPLICATION VIEWS

IN-PROCESS VIEW 1

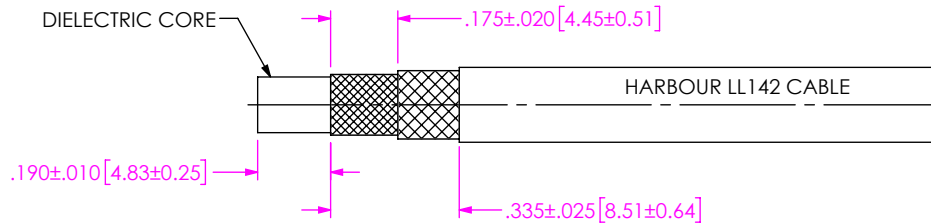

1. TRIM CABLE TO EXPOSE DIELECTRIC CORE AND BRAIDS AS SHOWN.

IN-PROCESS VIEW 2

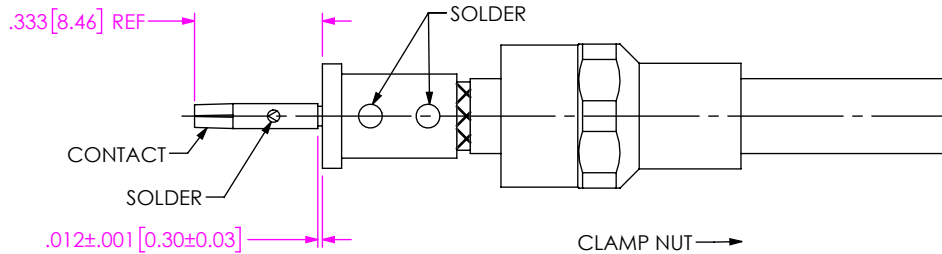

2A. SLIDE CLAMP NUT OVER CABLE IN ORIENTATION SHOWN.
 2B. INSERT CABLE INTO SOLDER FERRULE UNTIL INNER BRAID SEATS IN FERRULE. THEN SOLDER CABLE BRAIDS TO FERRULE WHERE SHOWN.
 2C. TRIM CABLE DIELECTRIC FLUSH WITH SOLDER FERRULE FACE. (DO NOT NICK CABLE CENTER CONDUCTOR)
 2D. SOLDER CONTACT WITH INDICATED GAP.

IN-PROCESS VIEW 3

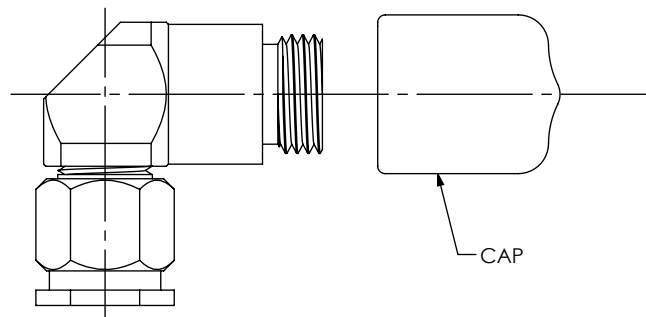

3. REMOVE AND DISCARD CAP

IN-PROCESS VIEW 4

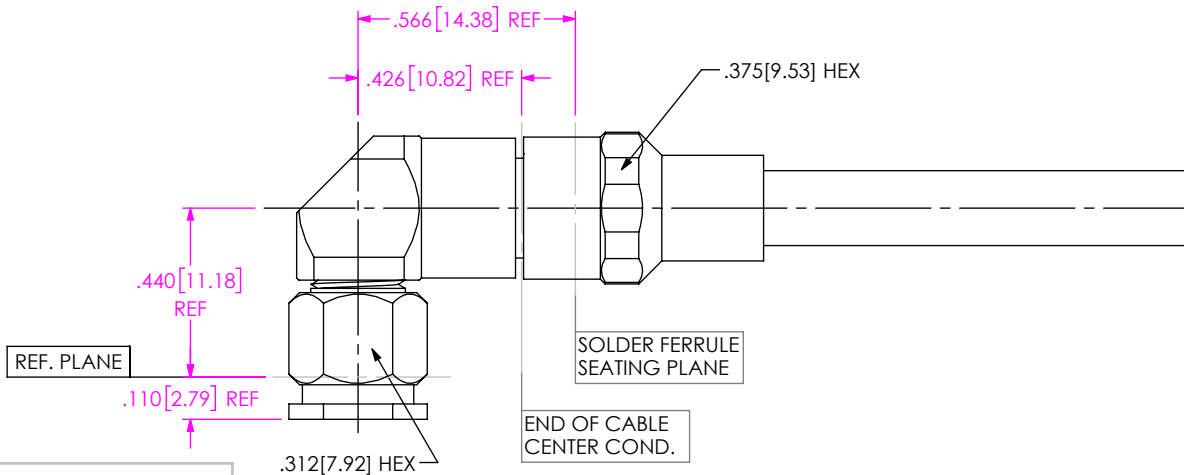

4. INSERT CABLE/CONTACT SUB-ASSEMBLY INTO CONNECTOR UNTIL SEATED AND TIGHTEN CLAMP NUT TO 35-45 IN-LBS.

PROPRIETARY NOTE
 THIS DOCUMENT CONTAINS CONFIDENTIAL AND PROPRIETARY INFORMATION AND ALL DESIGN, MANUFACTURING, REPRODUCTION, USE, PATENT RIGHTS AND SALES RIGHTS ARE EXPRESSLY RESERVED BY SAMTEC, INC. THIS DOCUMENT SHALL NOT BE DISCLOSED, IN WHOLE OR PART, TO ANY UNAUTHORIZED PERSON OR ENTITY NOR REPRODUCED, TRANSFERRED OR INCORPORATED IN ANY OTHER PROJECT IN ANY MANNER WITHOUT THE EXPRESS WRITTEN CONSENT OF SAMTEC, INC.



520 PARK EAST BLVD, NEW ALBANY, IN 47150
 PHONE: 812-944-6733 FAX: 812-948-5047
 e-Mail: info@SAMTEC.com code 55322

DO NOT SCALE DRAWING

SHEET SCALE: 2:1

DESCRIPTION: SMA RT. ANGLE PLUG, SOLDER CLAMP FOR HARBOUR LL142 CABLE, L/W HOLES

DWG. NO. PRF01-P-C-EP-142-RS-1

BY: ETHAN C 05/07/2021 SHEET 2 OF 2