

DO NOT SCALE FROM THIS PRINT

**DESIGNED & DIMENSIONED IN INCHES[MILLIMETERS]
ALL DIMENSIONS REFERENCE EXCEPT AS SHOWN**

PRF01-P-C-EP-335A-RS

SERIES
-01: SMA

GENDER
-P: PLUG

TYPE
-C: CABLE

TERMINATION
-S: SOLDER CLAMP

ORIENTATION
-R: RIGHT ANGLE

CABLE TYPE
-335A: HARBOUR LL335I

FINISH
-EP: 50µ" EXTRA HEAVY GOLD CENTER CONTACT, PASSIVATED OUTER CONTACT

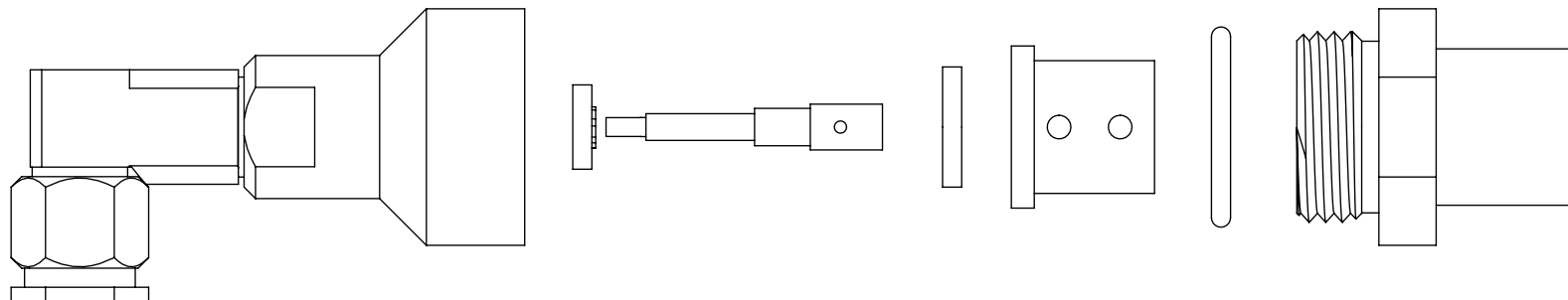
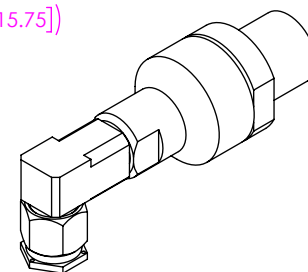
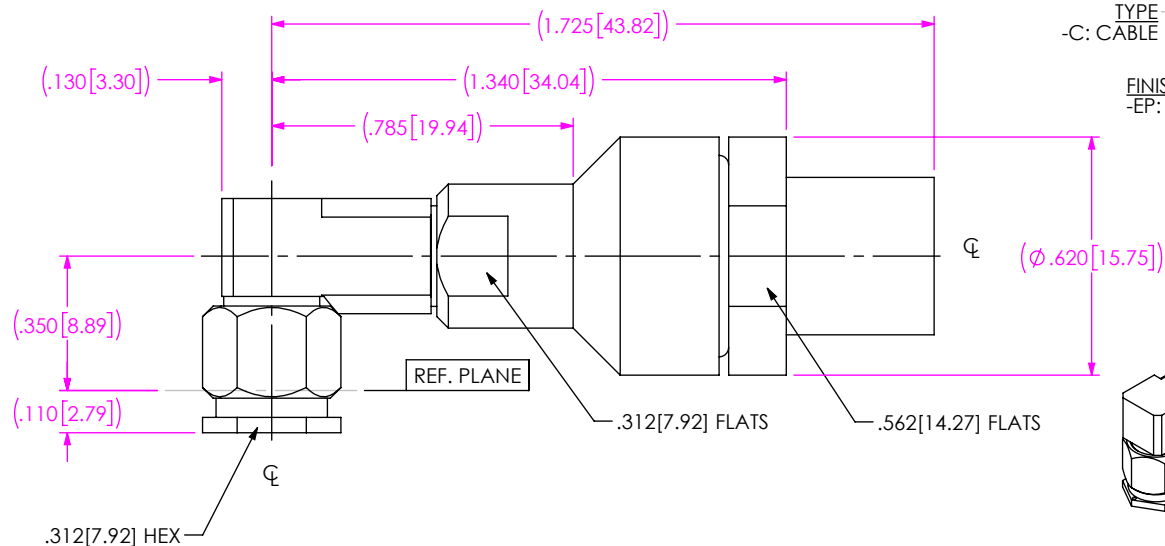

**EXPLODED VIEW
NOT TO SCALE
(FOR CLARITY ONLY)**

NOTES:

1. MATERIAL:
 BODY, COUPLING & CLAMP NUTS: STAINLESS STEEL.
 CONTACT & LOCK RING: BERYLLIUM COPPER.
 SOLDER FERRULE: BRASS.
 GASKET & O-RING: SILICONE RUBBER.
 INSULATORS: PTFE.
 DIELECTRIC BEADS: ULTEM 1000.
2. FINISH:
 BODY, COUPLING & CLAMP NUTS: PASSIVATED.
 CONTACT: 50µ" MIN. GOLD OVER 50µ" MIN. NICKEL PLATE.
 SOLDER FERRULE: 10µ" MIN. GOLD OVER 50µ" MIN. NICKEL PLATE.
3. DELETED NOTE.

<p>PROPRIETARY NOTE</p> <p>THIS DOCUMENT CONTAINS CONFIDENTIAL AND PROPRIETARY INFORMATION AND ALL DESIGN, MANUFACTURING, REPRODUCTION, USE, PATENT RIGHTS AND SALES RIGHTS ARE EXPRESSLY RESERVED BY SAMTEC, INC. THIS DOCUMENT SHALL NOT BE DISCLOSED, IN WHOLE OR PART, TO ANY UNAUTHORIZED PERSON OR ENTITY NOR REPRODUCED, TRANSFERRED OR INCORPORATED IN ANY OTHER PROJECT IN ANY MANNER WITHOUT THE EXPRESS WRITTEN CONSENT OF SAMTEC, INC.</p>	<p>520 PARK EAST BLVD, NEW ALBANY, IN 47150 PHONE: 812-944-6733 FAX: 812-948-5047 e-Mail info@SAMTEC.com code 55322</p>
	<p>DESCRIPTION: SMA RA PLUG, SOLDER CLAMP FOR HARBOUR LL335I CABLE</p>
	<p>DWG. NO. PRF01-P-C-EP-335A-RS</p>
<p>SHEET SCALE: 2:1 DO NOT SCALE DRAWING</p>	<p>BY: HENSON T 07/30/2020 SHEET 1 OF 3</p>

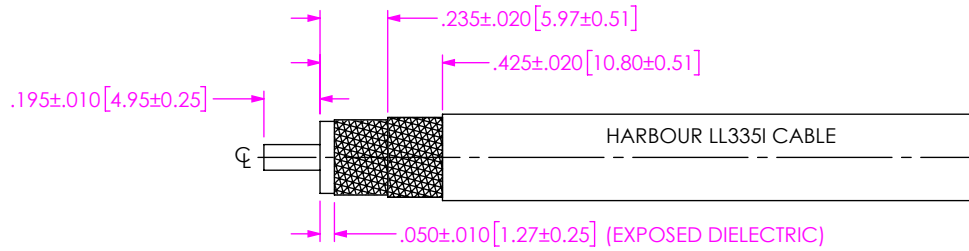

1. TRIM CABLE TO EXPOSE BRAIDS AND DIELECTRIC AS SHOWN.

IN-PROCESS 1

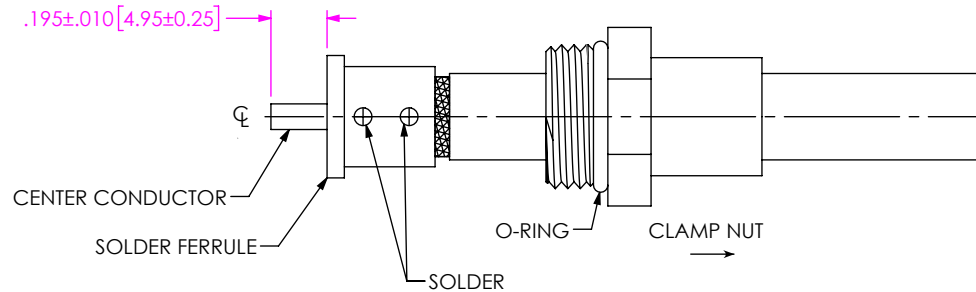

2A. INSERT CABLE INTO SOLDER FERRULE UNTIL BRAIDS SEAT IN FERRULE. THEN SOLDER BOTH CABLE BRAIDS WHERE SHOWN.

2B. TRIM CABLE DIELECTRIC FLUSH WITH FACE OF FERRULE.

IN-PROCESS 2

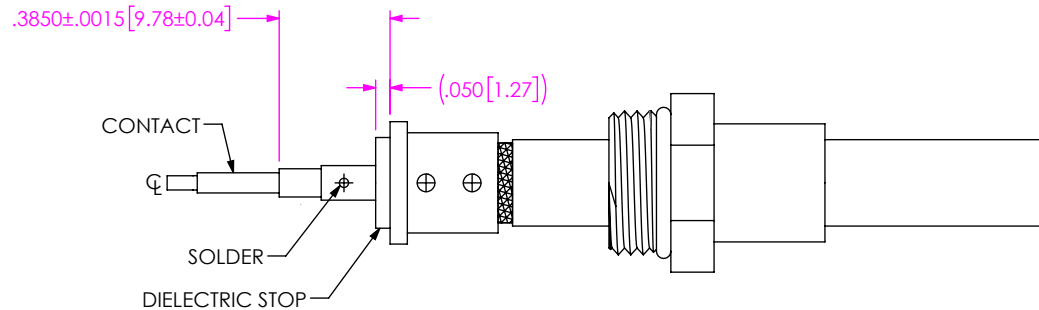

3A. SLIDE DIELECTRIC STOP (ϕ .315 [8.00] OD) ONTO CABLE CENTER CONDUCTOR AGAINST FACE OF SOLDER FERRULE.

3B. SOLDER CONTACT FLUSH TO DIELECTRIC STOP TO DIMENSION SHOWN.

IN-PROCESS 3

PROPRIETARY NOTE
 THIS DOCUMENT CONTAINS CONFIDENTIAL AND PROPRIETARY INFORMATION AND ALL DESIGN, MANUFACTURING, REPRODUCTION, USE, PATENT RIGHTS AND SALES RIGHTS ARE EXPRESSLY RESERVED BY SAMTEC, INC. THIS DOCUMENT SHALL NOT BE DISCLOSED, IN WHOLE OR PART, TO ANY UNAUTHORIZED PERSON OR ENTITY NOR REPRODUCED, TRANSFERRED OR INCORPORATED IN ANY OTHER PROJECT IN ANY MANNER WITHOUT THE EXPRESS WRITTEN CONSENT OF SAMTEC, INC.



520 PARK EAST BLVD, NEW ALBANY, IN 47150
 PHONE: 812-944-6733 FAX: 812-948-5047
 e-Mail info@SAMTEC.com code 55322

DO NOT SCALE DRAWING

SHEET SCALE: 1.5:1

DESCRIPTION: SMA RA PLUG, SOLDER CLAMP FOR HARBOUR LL335I CABLE

DWG. NO. PRF01-P-C-EP-335A-RS

BY: HENSON T 07/30/2020 SHEET 2 OF 3

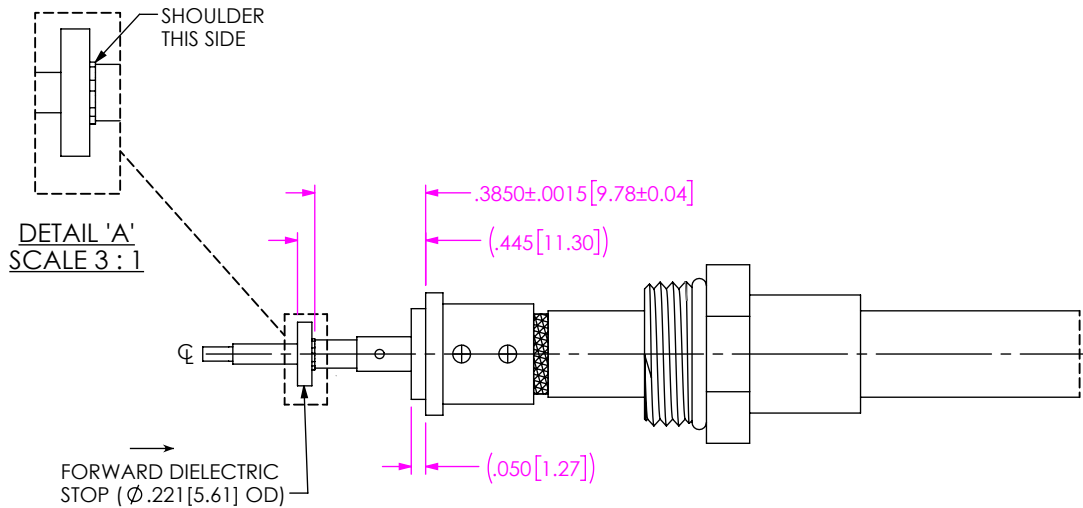

4. SLIDE FORWARD DIELECTRIC STOP ONTO CONTACT. AGAINST SHOULDER AS SHOWN.

IN-PROCESS 4

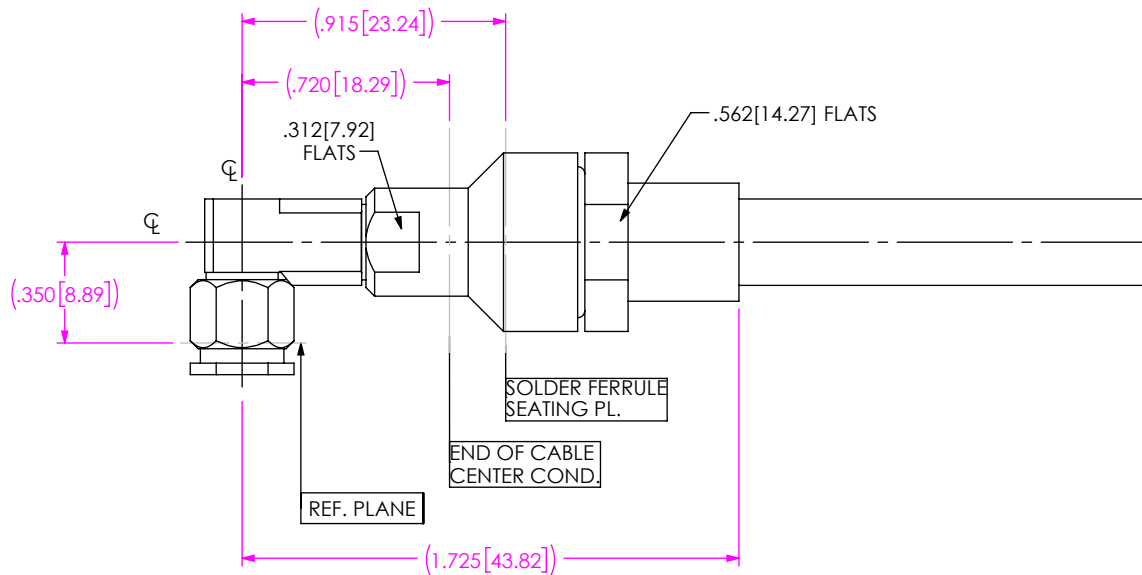

5. INSERT CABLE/CONTACT SUB-ASSEMBLY INTO CONNECTOR UNTIL SEATED AND TIGHTEN CLAMP NUT TO 35-45 IN-LBS.

IN-PROCESS 5

PROPRIETARY NOTE
 THIS DOCUMENT CONTAINS CONFIDENTIAL AND PROPRIETARY INFORMATION AND ALL DESIGN, MANUFACTURING, REPRODUCTION, USE, PATENT RIGHTS AND SALES RIGHTS ARE EXPRESSLY RESERVED BY SAMTEC, INC. THIS DOCUMENT SHALL NOT BE DISCLOSED, IN WHOLE OR PART, TO ANY UNAUTHORIZED PERSON OR ENTITY NOR REPRODUCED, TRANSFERRED OR INCORPORATED IN ANY OTHER PROJECT IN ANY MANNER WITHOUT THE EXPRESS WRITTEN CONSENT OF SAMTEC, INC.



520 PARK EAST BLVD, NEW ALBANY, IN 47150
 PHONE: 812-944-6733 FAX: 812-948-5047
 e-Mail info@SAMTEC.com code 55322

DO NOT SCALE DRAWING

SHEET SCALE: 1.5:1

DESCRIPTION: SMA RA PLUG, SOLDER CLAMP FOR HARBOUR LL335I CABLE

DWG. NO. PRF01-P-C-EP-335A-RS

BY: HENSON T 07/30/2020 SHEET 3 OF 3